

Bay Area Air Quality Management District

939 Ellis Street
San Francisco, CA 94109
(415) 771-6000

**Permit Evaluation
and
Statement of Basis
for
RENEWAL of**

MAJOR FACILITY REVIEW PERMIT

**for
Valero Benicia Asphalt Plant
Facility # A0901**

Facility Address:

3001 Park Road
Benicia, CA 94510

Mailing Address:

3400 East Second Street
Benicia, CA 94510

Application Engineer: Thu Bui
Site Engineer: Thu Bui

Application: 18289

TABLE OF CONTENTS

A.	Background	3
B.	Facility Description	4
C.	Permit Content.....	5
I.	Standard Conditions	5
II.	Equipment	6
III.	Generally Applicable Requirements	8
IV.	Source-Specific Applicable Requirements.....	10
V.	Schedule of Compliance.....	21
VI.	Permit Conditions.....	22
VII.	Applicable Limits and Compliance Monitoring Requirements	26
VIII.	Test Methods	33
IX.	Permit Shield:	35
X.	Revision History.....	38
XI.	Glossary.....	38
XII.	Appendix A - State Implementation Plan.....	38
D.	Alternate Operating Scenarios:	38
E.	Compliance Status:.....	38
F.	Differences between the Application and the Proposed Permit:	38
	APPENDIX A – BAAQMD Compliance Report.....	39
	APPENDIX B – Permit Evaluations.....	43

Title V Statement of Basis

A. Background

This facility is subject to the Operating Permit requirements of Title V of the federal Clean Air Act, Part 70 of Title 40 of the Code of Federal Regulations (CFR), and BAAQMD Regulation 2, Rule 6, Major Facility Review because it is a major facility as defined by BAAQMD Regulation 2-6-212. It is a major facility because it has the “potential to emit” (as defined by BAAQMD Regulation 2-6-218) more than 100 tons per year of a regulated air pollutant, more than 10 tons per year of a hazardous air pollutant, or more than 25 tons per year of a combination of hazardous air pollutants.

Major Facility Operating permits (Title V permits) must meet specifications contained in 40 CFR Part 70 as contained in BAAQMD Regulation 2, Rule 6. The permits must contain all “applicable requirements” (as defined in BAAQMD Regulation 2-6-202), monitoring requirements, recordkeeping requirements, and reporting requirements. The permit holders must submit reports of all monitoring at least every six months and compliance certifications at least every year.

In the Bay Area, state and District requirements are also applicable requirements and are included in the permit. These requirements can be federally enforceable or non-federally enforceable. All applicable requirements are contained in Sections I through VI of the permit.

Each facility in the Bay Area is assigned a facility identifier that consists of a letter and a 4-digit number. This identifier is also considered to be the identifier for the permit. The identifier for this facility is A0901.

This facility received its initial Title V permit on December 1, 2003. This application is for a permit renewal. Although the current permit expired on November 30, 2008, it continues in force until the District takes final action on the permit renewal. This Title V permit renewal has been updated to include new standard language used in all Title V permits. The proposed permit shows all changes to the permit in strikeout/underline format.

The Renewal permit would incorporate the following recent Title V revision applications into the permit:

Application Number(s) TV/NSR	Description
17031/17030	A-31 Incorporate Temperature Excursion Language
19194/19193	Atmospheric PRD Removal
19635/19384	Proposed Changes to Permit Conditions A-31 (H-4607) Thermal Oxidizer and S-24 (H-4603) Hot Oil Heater
19643/19631	Compliance Option for Benzene Waste NESHAP 40 CFR, Part 61 Subpart FF
21641/TBD	Addition of A17, Archiving of A4, S14, and S15

The incorporation of these applications would not significantly increase emissions. There are no emission increases for any of these applications.

17031/17030 – Incorporates temperature excursion language for A-31. Documentation of the allowable period for temperature excursions does not result in an emission increase.

19194/19193 - Removal of the atmospheric PRD and the burner replacement at S-19 will continue to comply with the 25 ppmv NO_x limit of Condition 1240.I.8 and 50 ppmv limit of Condition 1240.I.5b and CO emissions (1.47 lb/hr) of Condition 1240.5C. Combusting only clean natural gas in the existing burners will ensure SO₂, particulate and VOC emissions will not increase. There is a net decrease in fugitive emissions associated with the project.

19635/19384 – Proposed changes for A-31 Thermal Oxidizer and S-24 Hot Oil Heater to revise the conditions associated with the required minimum combustion zone temperature do not result in an emissions increase.

19643/19631 – Shut down of S-25, S-12, S-26, S-28 wastewater tanks are being exempted because the hydrocarbon contents are less than 1% per Regulation 2-1-123.3, clarification of the applicable requirements for the Benzene Waste Operations NESHAP (40 CFR 61 Subpart FF) in the Title V Permit to reflect the compliance option selected by Valero for the Benicia Asphalt Plant. Valero has elected to comply with the Treat to 6 (6BQ) compliance option at 40 CFR, Part 61.342(e) for the Benzene Waste Operations NESHAP, 40 CFR, Part 61 Subpart FF. There are no emission increases for these applications.

21641/TBD – Permitting of A17 as a grandfathered source because it was combined as part of A4 and was the actual abatement device for S17 Asphalt Truck Loading Rack. Archiving of A14 and S14 Naphtha Truck Loading Rack and S15 Gas Oil Truck Loading Rack. S14 had been included in the renewal draft Title V permit as an administrative revision, but was later combined into Application number 21641 for A17 and S15. Application includes revision of minimum operating temperature at A17 from 1400 F to 1570 F to meet the 99.3 POC destruction efficiency requirement.

B. Facility Description

The Valero Benicia Asphalt Plant is a small-scale petroleum refinery that primarily produces asphalt from crude oil. The by-products (naphtha, kerosene, and gas oil) are transferred to the adjacent Valero fuel refinery or sold to other companies for the production of other petroleum products.

The processes used at the facility are: distillation, vacuum distillation, blending, organic liquid storage, asphalt storage, organic liquid loading, and asphalt loading.

A detailed description of petroleum refinery processes and the resulting air emissions may be found in Chapter 5 of EPA's publication AP-42, Compilation of Air Pollutant Emission Factors. This document may be found at:

<http://www.epa.gov/ttn/chief/ap42>

This document contains descriptions of tank and their emissions and combustion units and their emissions.

The principal sources of air emissions from this refinery are:

- Combustion units (furnaces, boilers, and incinerators)
- Storage tanks
- Fugitive emissions from pipe fittings, pumps, and compressors
- Wastewater treatment facilities

Combustion unit emissions are generally controlled through the use of burner technology. Storage tank emissions are controlled through the use of add-on control and or fitting loss control. Fugitive emissions have been controlled through the use of inspection and maintenance. Wastewater treatment facilities are controlled by covering units, gasketing covers, and add on controls, such as carbon canisters. Caustic scrubbers control the H₂S in the refinery gas from the crude distillation.

There has been no significant change in emissions.

C. Permit Content

The legal and factual basis for the permit follows. The permit sections are described in the order presented in the permit. Generally, this statement of basis/permit evaluation addresses only the proposed revisions to the permit. Comprehensive statements of basis were prepared for the previous issues of the permit and are available on request.

I. Standard Conditions

This section contains administrative requirements and conditions that apply to all facilities. If the Title IV (Acid Rain) requirements for certain fossil-fuel fired electrical generating facilities or the accidental release (40 CFR § 68) programs apply, the section will contain a standard condition pertaining to these programs. Many of these conditions derive from 40 CFR § 70.6, Permit Content, which dictates certain standard conditions that must be placed in the permit. The language that the District has developed for many of these requirements has been adopted into the BAAQMD Manual of Procedures, Volume II, Part 3, Section 4, and therefore must appear in the permit.

The standard conditions also contain references to BAAQMD Regulation 1 and Regulation 2. These are the District's General Provisions and Permitting rules.

Changes to permit:

- Regulation 2, Rule 5 – New Source Review of Toxic Air Contaminants has been added to Standard Condition 1.A.
- The following language was added to Standard Condition I.B.1: “If the permit renewal has not been issued by November 30, 2008, but a complete application for renewal has been submitted in accordance with the above deadlines, the existing permit will continue in force until the District takes final action on the renewal application.” This is the “application shield” pursuant to BAAQMD Regulation 2-6-407.
- Standard Condition I.B.11, was updated to add the basis of Reg 2-6-409.20 which requires the responsible official to certify all documents submitted, was added to conform to changes in Regulation 2, Rule 6.
- The following language was added as Standard Condition I.B.12: “The permit holder is responsible for compliance, and certification of compliance, with all conditions of the permit, regardless whether it acts through employees, agents, contractors, or subcontractors. (Regulation 2-6-307).” The purpose is to reiterate that the Permit Holder is responsible for ensuring that all activities at the facility comply with all applicable requirements.
- The dates of the reporting periods and reporting deadlines have been added and revised to Standard Conditions I.F and I.G for additional clarity.
- The first sentence of Standard Condition I.F has been changed from “All required monitoring reports must be submitted to the District at least once every six months.” to “Reports of all required monitoring must be submitted to the District at least once every six months, except where an applicable requirement specifies more frequent reporting.” to conform to BAAQMD Regulation 2-6-409.18.
- The language in I.J.1 was revised to be consistent with Valero’s Refinery TV permit.

II. Equipment

This section of the permit lists all permitted or significant sources. Each source is identified by an S and a number (e.g., S24).

Permitted sources are those sources that require a BAAQMD operating permit pursuant to BAAQMD Rule 2-1-302.

Significant sources are those sources that have a potential to emit of more than 2 tons per year of a “regulated air pollutant” (as defined in BAAQMD Rule 2-6-222) or 400 pounds per year of a “hazardous air pollutant” (as defined in BAAQMD Rule 2-6-210).

All abatement (control) devices that control permitted or significant sources are listed. Each abatement device whose primary function is to reduce emissions is identified by an A and a number (e.g., A-24). If a source is also an abatement device, such as when an engine controls VOC emissions, it will be listed in the abatement device table but will have an “S” number. An abatement device may also be a source (such as a thermal oxidizer that burns fuel) of secondary emissions. If the primary function of a device is to control emissions, it is considered an abatement (or “A”) device. If the primary function of a device is a non-control function, the device is considered to be a source (or “S”).

The equipment section is considered to be part of the facility description. It contains information that is necessary for applicability determinations, such as fuel types, contents or sizes of tanks, etc. This information is part of the factual basis of the permit.

Each of the permitted sources has previously been issued a permit to operate pursuant to the requirements of BAAQMD Regulation 2, Permits. These permits are issued in accordance with state law and the District's regulations. The capacities in the permitted sources table are the maximum allowable capacities for each source, pursuant to Standard Condition I.J and Regulation 2-1-403.

Following are explanations of the differences in the equipment list between the time that the facility originally applied for a Title V permit and the permit proposal date:

Changes to permit:

- Table IIA – Permitted Sources
 - Delete S-14. Source has been demolished
 - Delete S-15. Source has been shutdown and permit to operate has been archived
 - For S-19, delete asphalt refinery fuel gas f to operate with natural gas only upon startup of the atmospheric PRD removal project (A/N 19194)
 - Add S-19 new source review throughput
 - S-23, remove 'Valero LP'
 - Delete S-39 and S-40. Sources permanently out of service; empty and blinded.
 - Delete S-25 per BWON A/N 19631/19643
 - Move exempt sources from Table IIA to new Table IIC
 - S-12, S-26, S-28 per BWON A/N 19631/19643
 - Editorial changes to correct source descriptions for S-1 – S-9, S-13, S-19 – S-24, S-27, S-34, S-37, S-38, S-41, S-51 – S-53, S-59 – S-63, S-65, S-67, and S-70
 - Add S-68, S-69. S-70 and S-71 new source review throughput or usage hours
- Table IIB – Abatement Devices
 - Incorporate rule updates:
 - BAAQMD Reg 6-1/SIP Reg 6.
 - SIP Reg 8-5
 - Delete S14. Source has been demolished
 - A4 (BAAQMD 8-6-301).
 - A4 (BAAQMD Condition #1240, Part I.14).
 - A4 (BAAQMD Condition #1240, Part II.60).
 - Delete S15. Source no longer in service
 - A4 (BAAQMD 8-6-301).
 - A4 (BAAQMD Condition #1240, Part I.14).
 - A4 (BAAQMD Condition # 1240, Part II.63).
 - For A4, replace with A17
 - BAAQMD 6-1-301/SIP 6-301.
 - BAAQMD 6-1-310/SIP 6-310.
 - BAAQMD #1240, Part I.14.

- BAAQMD # 1240, Part II.68.
- For S18, delete requirement for abatement by S19, A4, A44, and A45
 - S19 (BAAQMD Condition 1240, Parts 1.3 and I.14, and 40 CFR 63.643(a)(2))
 - A4 (BAAQMD Condition #1240, Part II.6 and 40 CFR 60,482.10(c)).
 - A44 (None).
 - A45 (BAAQMD Condition #1240, Part I.11).
 - A45 (BAAQMD Condition #1240, Part I.12).
- For A31 and S24, revised abatement requirements to reflect changes to minimum operating temperature permit condition revisions per A/N 19635/19384
 - Added additional sources abated per Condition 1240.II.32a
 - Deleted Condition 1240.II.32b for S59
 - Deleted Condition 1240.II.32c for S63
 - Deleted Condition 1240.II.43 for S3
 - Deleted Condition 1240.II.55 for S5, S8, S37, S38, S70
 - Deleted Condition 1240.II.56 for S51-S53, S60
 - Deleted Condition 1240.II.56 for S65
 - Deleted Condition 1240.II.57 for S61, S62
 - Deleted Condition 1240.II.69 for S31
 - Deleted Condition 1240.II.70 for S54
 - Deleted Condition 1240.II.85 for S66
 - Deleted Condition 20278, Part 3 for S70
- For A1, A3, A31, and S24, delete S25 per BWON A/N 19631/19643
- For A4 abatement of S18, add comment that the abatement requirement will be deleted upon startup of the atmospheric PRD removal project (A/N 19194)
- For A31 and S24, delete S12, S26, S28 and add S27 and S67 per BWON A/N 19631/19643
- For A31 and S24, delete row for [40 CFR, Part 61.349(a)(2)(i)(A)] per BWON A/N 19631/19643
- For A44 and A45, add comment that abatement device will be deleted upon startup of the atmospheric PRD removal project (A/N 19194)
- For S19, add “and/or” to allow the source to operate with natural gas only upon startup of the atmospheric PRD removal project (A/N 19194)
- For S19, add comment that the abatement requirement for S18, A44, and A45 will be deleted upon startup of the atmospheric PRD removal project (A/N 19194)
- Table IIC – Exempt Sources
 - Add new table for exempt sources
 - Move exempt sources from Table IIA (S12, S26, S28) per BWON A/N 19631/19643
 - Add previously omitted exempt sources (TK-4609, TK-4618, TK-4666, TK-4673)
 - Add previously omitted fugitive sources (S32100 through S32105)

III. Generally Applicable Requirements

This section of the permit lists requirements that generally apply to all sources at a facility including insignificant sources and portable equipment that may not require a District permit. If

a generally applicable requirement applies specifically to a source that is permitted or significant, the standard will also appear in Section IV and the monitoring for that requirement will appear in Sections IV and VII of the permit. Parts of this section apply to all facilities (e.g., particulate, architectural coating, odorous substance, and sandblasting standards). In addition, standards that apply to insignificant or unpermitted sources at a facility (e.g., refrigeration units that use more than 50 pounds of an ozone-depleting compound) are placed in this section.

Unpermitted sources are exempt from normal District permits pursuant to an exemption in BAAQMD Regulation 2, Rule 1. They may, however, be specifically described in a Title V permit if they are considered “significant sources” as defined in BAAQMD Rule 2-6-239.

Changes to permit:

Section III has been modified to say that SIP standards are now found on the EPA website and are not included as part of the permit.

Table III has been updated by adding the following rules and standards to conform to current practice:

- BAAQMD Regulation 2, Rule 5, New Source Review of Toxic Air Contaminants
- BAAQMD Regulation 2, Rule 9, Permits, Interchangeable Emission Reduction Credits
- BAAQMD Regulation 3, Fees
- BAAQMD Regulation 6, Particulate Matter and Visible Emissions has been designated as SIP Regulation 6, since the rule has been renamed and renumbered as Regulation 6, Rule 1, Particulate Matter, General Provisions
- BAAQMD Regulation 8, Rule 15, Organic compounds – Emulsified and liquid Asphalts
- BAAQMD Regulation 8, Rule 40 Aeration of Contaminated Soil and Removal of Underground Storage Tanks
- SIP Regulation 8, Rule 40 Aeration of Contaminated Soil and Removal of Underground Storage Tanks
- BAAQMD Regulation 8, Rule 47, Air Stripping and Soil Vapor Extraction Operations
- SIP Regulation 8, Rule 47, Air Stripping and Soil Vapor Extraction Operations
- California Health and Safety Code Section 41750 et seq., Portable Equipment
- California Health and Safety Code Section 44300 et seq., Air Toxics “Hot Spots” Information and Assessment Act of 1987
- California Health and Safety Code Section 93116 et seq., Airborne Toxic Control Measure for Diesel Particulate Matter from Portable Engines Rated at 50 Horsepower and Greater

The dates of adoption or approval of the rules and their “federal enforceability” status in Table III have also been updated.

IV. Source-Specific Applicable Requirements

This section of the permit lists the applicable requirements that apply to permitted or significant sources. These applicable requirements are contained in tables that pertain to one or more sources that have the same requirements. The order of the requirements is:

- District Rules
- SIP Rules (if any) are listed following the corresponding District rules. SIP rules are District rules that have been approved by EPA for inclusion in the California State Implementation Plan. SIP rules are “federally enforceable” and a “Y” (yes) indication will appear in the “Federally Enforceable” column. If the SIP rule is the current District rule, separate citation of the SIP rule is not necessary and the “Federally Enforceable” column will have a “Y” for “yes”. If the SIP rule is not the current District rule, the SIP rule or the necessary portion of the SIP rule is cited separately after the District rule. The SIP portion will be federally enforceable; the non-SIP version will not be federally enforceable, unless EPA has approved it through another program.
- Other District requirements, such as the Manual of Procedures, as appropriate.
- Federal requirements (other than SIP provisions)
- BAAQMD permit conditions. The text of BAAQMD permit conditions is found in Section VI of the permit.
- Federal permit conditions. The text of Federal permit conditions, if any, is found in Section VI of the permit.

Section IV of the permit contains citations to all of the applicable requirements. The text of the requirements is found in the regulations, which are readily available on the District or EPA websites, or in the permit conditions, which are found in Section VI of the permit. All monitoring requirements are cited in Section IV. Section VII is a cross-reference between the limits and monitoring requirements. A discussion of monitoring is included in Section C.VII of this permit evaluation/statement of basis.

This permit did not require any complex applicability determinations.

Applicability of 40 CFR, Part 64, Compliance Assurance Monitoring (CAM)

40 CFR 64, Compliance Assurance Monitoring (CAM)

U.S. EPA developed 40 CFR 64 – Compliance Assurance Monitoring (CAM) in order to provide reasonable assurance that facilities comply with emissions limitations by monitoring the operation and maintenance of their control devices. The CAM rule was effective on November 21, 1997; however, most facilities are not affected by CAM requirements until renewal of their Title V Permit. As required, CAM requirements were evaluated as part of this Title V Permit renewal application.

In general, CAM applies to emission sources that meet *all* of the following conditions:

- The source is located at a major source for which a Title V Permit is required; and

- The source is subject to a federally enforceable emission limitation or standard; and
- The source uses a control device to achieve compliance with a federally enforceable emission limit or standard; and
- The source has potential pre-control emissions of the applicable regulated air pollutant that are equal to or greater than the amount, in tons per year, for a source to be classified as a major source (100 tons per year of any criteria pollutant, 10 tons per year of any hazardous air pollutant, or 25 tons per year of any combination of hazardous air pollutants; and
- The source is not otherwise exempt from CAM.

Exemptions that could potentially apply to emission sources at the Valero Benicia Refinery are specified in 40 CFR 64.2(b)(1) – Exempt Emission Limitations or Standards:

- Emission limitations or standards proposed by the Administrator after November 15, 1990 pursuant to section 111 or 112 of the Act (§64.2(b)(1)(i)); or
- Emission limitations or standards for which a Title V Permit specifies a continuous compliance determination method (a method, specified by the applicable standard or an applicable permit condition, which: (1) Is used to determine compliance on a continuous basis, consistent with the averaging period established for the emission limitation or standard; and (2) Provides data either in units of the standard or correlated directly with the compliance limit) (§64.2(b)(1)(vi)).

The following criteria were used to identify emission sources at the Valero Benicia Asphalt Plant that were evaluated to determine CAM requirements:

- The source is included in the existing Title V Permit; and
- The source has an abatement device (used for routine operations) as shown in Table IIB of the Title V Permit.

The table at the end of Attachment C – Rev 1 contains a summary of the evaluation of CAM requirements for the emission sources that met these criteria. Based on review of these criteria, none of the emission sources at the Benicia Asphalt Plant are subject to CAM requirements. Review of the facility potential to emit further supports the conclusion that none of the emission sources at the Benicia Asphalt Plant are subject to CAM requirements. This determination is supported by the following considerations:

- The Benicia Asphalt Plant was formerly the Huntway Refining Facility. It was purchased by Valero Refining Company – California on June 1, 2001. Although the original Title V permit application submitted by Huntway indicated that the potential to emit was less than the threshold for a major facility, the Benicia Asphalt Plant was considered to be a “smaller facility” only subject to major facility review consistent with BAAQMD Regulation 2-6-312 (because it had actual emissions that exceeded the specified thresholds prior to July 24, 1995); and
- Based on good engineering judgment and knowledge of actual facility emissions, it is estimated that the facility pre-control potential to emit for regulated air pollutants is less than the major source threshold. Therefore, no single source would have potential pre-control emissions above the major source definition.

Changes to permit:

Section IV has been modified to say that SIP standards are now found on EPA's website and are not included as part of the permit.

The following regulations have been updated throughout Section IV:

- BAAQMD Regulation 6, Rule 1 - Particulate Matter and Visible Emissions;
- BAAQMD Regulation 8, Rule 5 - Organic Compounds, Storage of Organic Liquids;
- SIP Regulation 8, Rule 5 - Organic Compounds, Storage of Organic Liquids;
- 40 CFR, Part 60 Subpart J – Standards of Performance for Petroleum Refineries

Added Regulation 10 citations for 40 CFR, Part 60 Subparts found in Section IV tables;

Revised source description in table headers to include full facility equipment numbering IDs in 46xx format

Made editorial corrections throughout Section IV

Removed footnote at end of Table IVs regarding SIP and removed footnote 1 in Federal Enforceability column

Table IV – Multiple

- Updated BAAQMD Regulation 6, Rule 1 (renumbered), and added SIP Reg 6, including the addition BAAQMD 6-401 and SIP 6-1-401
- Updated BAAQMD and SIP Regulation 9, Rule 10 to reflect SIP adoption on 4/2/2008 and to delete past due requirements (e.g., 9-10-401/402 control plan submittal)
- Revised the name format used for 40 CFR Part 60, 61, and 63 citations for consistency with the remainder of the permit
- Updated Condition 21233 federally enforceable to “Y” to reflect SIP adoption of BAAQMD Regulation 9, Rule 10

Table IV-A

- Correct federal applicability for BAAQMD 8-8-601 and remove SIP 8-8-601
- Move BAAQMD Regulation, 8, Rule 10 from Table IV-L for S-18 to Table IV-A because process vessels are located throughout the facility, not only in the crude unit
- Add Regulation 11, Rule 12 for 40 CFR, Part 61 Subpart FF
- 40 CFR, Part 61 Subpart FF requirements.
 - Corrections to applicability per BWON A/N 19631/19643
- 40 CFR, Part 63 Subpart CC requirements.
 - Delete incomplete description for 63.641 (definitions)
 - Correct title of Table 6
- 40 CFR, Part 98 Subpart A,C, Y and MM, incorporated for Mandatory Greenhouse Gas Reporting requirements

Table IV-B (S1, S2, S4, S23)

- Remove remaining table header. Sources transferred to Facility B5574 and table rows deleted in Revision 2

Table IV-B (S3)

- Renumber, was Table IV-C
- 40 CFR, Part 63 Subpart CC requirements
 - Add description to title row.
 - Add 40 CFR, Part 63.640(c)(2)
 - Correct 40 CFR, Part 63.654(i)(1) to 63.654(i)
 - Revise 40 CFR, Part 63.654(i)(1)(iv) description for clarification
- Condition 1240, Parts II.32a, II.94, II.95, II.96, add per A31/S24 A/N 19384/19635
- Condition 1240, Parts II.43 and II.44, delete per A31/S24 A/N 19384/19635
- Condition 1240, Part II.58b, correct per BWON A/N 19631/19643
- Condition 20762, add applicable condition

Table IV-C (S5, S6, S7, S8, S37, S38, S51, S52, S53, S60, S61, S62, S65)

- Consolidate Tables IV-D (S5, S6, S7, S8, S37, S38), IV-AB (S51, S52, S53, 60), IV-AE (S61, S62), and IV-AG (S65) and renumber as Table IV-C. These sources have similar regulatory applicability. Permit condition differences between the sources are noted.
- Condition 1240, Part 32a, II.93, II.94, II.95, II.96, add conditions per A31/S24 A/N 19384/19635
- Condition 1240, Part 55, per A31/S24 A/N 19384/19635
- 40 CFR, Part 60 Subpart UU
 - 40 CFR, Part 60.470(a) and (b), 60.474(c)(5) – add applicable citations
- 40 CFR, Part 63 Subpart CC requirements
 - Add description to title row
 - 40 CFR, Part 63.640(c)(2) – add applicable citations
 - Correct 40 CFR, Part 63.654(i)(1) to 63.654(i)
 - Revise 40 CFR, Part 63.654(i)(1)(iv) description for clarification

Table IV-D (S9)

- Add description to Title block
- Renumber, was Table IV-E
- SIP Regulation 8, Rule 5 requirements
 - Add SIP 8-5 applicability for slotted guidepoles to allow for removal of solid guidepole inserts.
 - Delete SIP 8-5 applicability for old style secondary seal gaps (8-5-322.3) because tank has zero gap secondary seals (subject to 8-5-322.5).
- Add Regulation 11, Rule 12 for 40 CFR, Part 61 Subpart FF per BWON A/N 19631/19643
- Add applicability for 40 CFR, Part 61 Subpart FF (Benzene Waste Operations NESHAP) per BWON A/N 19631/19643
- 40 CFR, Part 63 Subpart CC requirements
 - Editorial changes to descriptions for clarification

Table IV-E (S12, S26, S28)

- Add description to Title Block
- Consolidate Tables IV-F (S12), IV-R (S26) and IV-T (S28) and renumber as Table IV-E. These sources have similar regulatory applicability. Permit condition differences between the sources are noted.
- 40 CFR, Part 61 Subpart FF requirements – change applicability per BWON A/N 19631/19643
 - Add description to title row
 - Add applicable citations for uncontrolled aqueous waste streams complying with 61.342(e)(2)
 - Delete all other citations
- 40 CFR, Part 63 Subpart CC requirements
 - Add description to title row
 - Add 63.641 Definitions
 - Delete requirements for Group 1 wastewater (63.647 and 63.654). All BAP BWON waste streams are Group 2 wastewater

- Condition 1240 Part II.58b – delete condition because it is not applicable to these sources
- Condition 1240 Parts II.95, II.96, add conditions per A31/S24 A/N 19384/19635

Table IV-F (S13, S59, S63)

- Add description to Title block
- Consolidate Tables IV-F (S13), IV-AD (S59), IV-AF (S63) and renumber as Table IV-F. These sources have similar regulatory applicability. Permit condition differences between these sources are noted.
- 40 CFR, Part 63 Subpart CC requirements
 - Revise descriptions for clarification
- Condition 1240, Part II.32a, added BACT to basis per A31/S24 A/N 19384/19635
- Condition 1240, Parts II.93, II.94, II.95, II.96, add conditions per A31/S24 A/N 19384/19635

Table IV-H (S14) – Delete table. S14 has been demolished.

Table IV-G (S15) – Table deleted, source archived per A/N 21641

Table IV-H (S16) – Renumber, was Table IV-J

Table IV-I (S17) – Renumber, was Table IV-K

- Condition 1240, Part I.19, revised minimum operating temperature from 1400F to 1570F per A/N 21641

Table IV-J.1 (S18) – Deleted and replaced with Table IV-I per A/N 19194

Table IV-I (S18) (NEW – upon startup of atmospheric PRD removal project)

- Added new table to reflect revised applicability and permit conditions upon startup of the atmospheric PRD removal project (A/N 19194)
 - Delete BAAQMD Regulation, 8, Rule 10 from Table IV-L for S-18 and move to Table IV-A because process vessels are located throughout the facility, not only in the crude unit
 - 40 CFR, Part 63, Subpart CC requirements for Miscellaneous Process Vents, deleted regulation
 - Condition 1240, Part I.3, revised to reflect abatement by S9 refinery fuel gas system instead of S19 vacuum heater
 - Condition 1240, Part I.16b, deleted condition because POC destruction requirement no longer applicable
 - Condition 1240, Part II.6, deleted condition since exhaust from S18 Crude Unit will be routed from the S19, Vacuum Heater to the refinery fuel gas recovery system, S9 and is not longer required to vent to A4 thermal oxidizer

Table IV-K.1 (S19) – Deleted and replaced with Table IV-J per A/N 19194 and removal of Reg 9-10 and NOx Box conditions

Table IV-J (S19) (NEW – upon startup of atmospheric PRD removal project)

- Added new table to reflect revised applicability and permit conditions upon startup of the atmospheric PRD removal project (A/N 19194)
 - Regulation 1-107, Combination of emissions, deleted because emissions from S18 and S19 will no longer be combined
 - BAAQMD Regulation 1-520, 520.8, 522 (all citations, including SIP), and 602, Regulation 10, BAAQMD MOP – Volume V, NSPS Subparts A and J, NSPS Appendices B and F, and Condition 1240 Parts I.12 and I.13, deleted because NSPS J fuel gas H₂S limit and monitoring will no longer apply
 - BAAQMD Regulation 2, Rule 9, BAAQMD Regulation 9, Rule 10, Condition 19329, and Condition 21233, deleted because S19 is subject to NSR therefore NO_x box condition, Reg 2-9, and Reg 9-10 do not apply
 - 40 CFR, Part 63 Subpart CC, deleted because miscellaneous process vent abatement requirements no longer apply
 - Condition 1240.I.3, deleted because S19 requirement to abate S18 offgas will no longer apply

Table IV-L (S20)

- Renumber, was Table IV-N
- Added comment to Condition 19329 that condition to be deleted upon expiration of NO_x IERCs from Facility B2626
- Delete past due future effective date for Condition 21223

Table IV-M (S21)

- Renumber, was Table IV-O
- Added comment to Condition 19329 that condition to be deleted upon expiration of NO_x IERCs from Facility B2626
- Delete past due future effective date for Condition 21223

Table IV-N (S24)

- Renumber, was Table IV-P
- Regulation 1, correct effective date
- Regulation 8, Rule 8 and SIP Regulation 8, Rule 8 requirements
 - Correct description of 8-8-301.3 for clarification
 - Add 8-8-305 and 8-8-305.2 requirements for S27 and S67 per BWON A/N 19631/19643
- 40 CFR, Part 60 Subpart A – delete because redundant with Table IV-A
- 40 CFR, Part 60 Subpart Kb – add description to title row
- 40 CFR, Part 60 Subpart UU requirements
 - 40 CFR, Part 60.470(a) and (b), 60.474(c)(5) – add applicable citations
- 40 CFR, Part 61 Subpart FF requirements – delete per BWON A/N 19631/19643
- Condition 1240 requirements
 - Modify descriptions for clarification
 - Part II.10, delete per BWON A/N 19631/19643

- Part II.32a, add additional abated sources and BACT to basis per A31/S24 A/N 19384/19635
- Parts II.32b, II.32c, II.32d, II.43, II.44, II.53, II.55, II.56, II.57, II.67, II.70, II.85, II.86, delete per A31/S24 A/N 19384/19635
- Part II.58c, II.58d, II.58e, II.58f, add per A31/S24 A/N 19384/19635

Table IV-Q (S25) – Delete source per BWON A/N 19631/19643

Table IV-R (S26) – Delete table and move source to Table IV-E

Table IV-O (S27, S67)

- Consolidate Tables IV-S (S27) and IV-AI (S67) and renumber to Table IV-O. These sources have similar regulatory applicability. Permit condition differences between the sources are noted.
- Delete Regulation 8-5 and SIP 8-5 per BWON A/N 19631/19643
- Add Regulation 8-8 and SIP 8-8 per BWON A/N 19631/19643
- 40 CFR, Part 61 Subpart FF requirements – change applicability per BWON A/N 19631/19643
 - Add description to title row
 - Add applicable citations for uncontrolled aqueous waste streams complying with 61.342(e)(2)
 - Delete all other citations
- 40 CFR, Part 63 Subpart CC – add applicable regulation and citations per BWON A/N 19631/19643. Do not add citations for Group 1 wastewater (63.647 and 63.654). All BAP BWON waste streams are Group 2 wastewater
- Condition 1240, Part II.58b – add applicable condition
- Condition 1240, Parts II.95 and II.96, add conditions per A31/S24 A/N 19384/19635

Table IV-T (S28) – Delete table and move source to Table IV-E

Table IV-P (S31)

- Renumber, was Table IV-W
- Condition 1240 requirements
 - Part II.32a, II.94, II.95, II.96, add A31/S24 A/N 19384/19635
 - Part II.58b, correct per BWON A/N 19631/19643
 - Parts II.66 and II.69, delete per A31/S24 A/N 19384/19635

Table IV-Q (S34) – Renumber, was Table IV-X

Table IV-Y (S39) – Delete table. Source is permanently out of service

Table IV-Z (S40) – Delete table. Source is permanently out of service

Table IV-R (S41)

- Renumber, was Table IV-AA

- Correct federal enforceability for BAAQMD 8-8 and SIP 8-8
- 40 CFR, Part 61 Subpart FF requirements – change applicability per BWON A/N 19631/19643
 - Add description to title row
 - Add applicable citations for uncontrolled aqueous waste streams complying with 61.342(e)(2)
 - Delete all other citations
- 40 CFR, Part 63 Subpart CC requirements
 - Add description to title row
 - Add 63.641 Definitions
 - Delete requirements for Group 1 wastewater (63.647 and 63.654). All BAP BWON waste streams are Group 2 wastewater
- Condition 1240, Part II.32a, II.93, II.95, II.96, add per A31/S24 A/N 19384/19635

Table IV-AB (S51, S52, S53, S60) – Delete table and move sources to Table IV-C

Table IV-S (S54)

- Renumber, was Table IV-AC
- Condition 1240 requirements
 - Part II.32a, II.94, II.95, II.96, add conditions per A31/S24 A/N 19384/19635
 - Part II.58b, correct per BWON A/N 19631/19643
 - Part II.67, II.70, II.85, delete per A31/S24 A/N 19384/19635

Table IV-AD (S59) – Delete table and move source to Table IV-F

Table IV-AE (S61, S62) – Delete table and move sources to Table IV-C

Table IV-AF (S63) – Delete table and move source to Table IV-F

- Condition 1240, Part II.32d, delete per A31/S24 A/N 19384/19635

Table IV-AG (S65) – Delete table and move sources to Table IV-C

- Condition 1240, Part II.53, delete per A31/S24 A/N 19384/19635

Table IV-T (S66)

- Add description to Title block
- Renumber, was Table IV-AH
- Regulation 8, Rule 8 and SIP 8-8, correct federal enforceability
- 40 CFR, Part 61 Subpart FF requirements – change applicability per BWON A/N 19631/19643
 - Add description to title row
 - Add applicable citations for uncontrolled aqueous waste streams complying with 61.342(e)(2)
 - Delete all other citations
- 40 CFR, Part 63 Subpart CC requirements
 - Add description to title row

- Add 63.641 Definitions
- Delete requirements for Group 1 wastewater (63.647 and 63.654). All BAP BWON waste streams are Group 2 wastewater
- Condition 1240 requirements
 - Part II.32a, II.93, II.95, II.96, add conditions per A31/S24 A/N 19384/19635
 - Part II.58b, correct per BWON A/N 19631/19643
 - Part II.85, II.86, delete per A31/S24 A/N 19384/19635

Table IV-AI (S67) – Delete table and move source to Table IV-O

Table IV-U (S68)

- Renumber, was Table IV-AJ
- Incorporate rule update for BAAQMD 9-8
- CARB ATCM, add /CCR, Title 17, Section 93115 for stationary diesel engines
- Condition 22851, add boilerplate ATCM condition for firewater pumps

Table IV-V (S69) – Renumber, was Table IV-AK

Table IV-W (S70)

- Renumber, was Table IV-AL
- 40 CFR, Part 60 Subpart UU
 - 40 CFR, Part 60.470(a) and (b), 60.474(c)(5) – add applicable citations
- Condition 1240 requirements
 - Part II.58b, correct per BWON A/N 19631/19643
 - Part II.32a, II.94, II.95, II.96, add per A31/S24 A/N 19384/19635
 - Part II.55, delete per A31/S24 A/N 19384/19635
- Condition 20278, Part 3, deleted per A31/S24 A/N 19384/19635

Table IV-W0 (Fugitive Matrix)

- Renumber, was Table IV-AM
- Modify row for Wastewater Treatment Plant sources per BWON A/N 19631/19643
- Delete row for S14 Naphtha loading rack. S14 has been demolished.
- Add row for S9 Naphtha tank fill line and naphtha transfer line from S9 to Refinery per BWON A/N 19631/19643
- Remove “including natural gas piping” from Fuel gas system row and add “including natural gas piping” to All Other Piping row because natural gas piping is subject to 40 CFR, Part 63 Subpart CC and fuel gas system is exempt from 40 CFR, Part 63 Subpart CC.
- Remove column for BAAQMD & SIP Regulation 8, Rule 28 because this rule is no longer a fugitive rule. A new table (IV-X2) has been added to show applicability for this rule.
- Remove column for NSPS Part 60, Subpart QQQ; BAAQMD Regulation 10-69 and add Note 4 because no sources at the Asphalt Plant are subject to Subpart QQQ
- Add columns for 40 CFR, Part 60 Subpart GGG/VV and 40 CFR, Part 60 Subpart GGGa/VVa – add applicable regulations
- Add applicable notes to columns and rows
- Modify headings for clarification

- S15 Gas Oil Loading Rack, deleted because source archived row per A/N 21641
- S18 Crude Unit, corrected equipment descriptions and added notes to identify equipment that will be either removed or added as part of the atmospheric PRD removal project (A/N 19194)
- S18 Vacuum Tower, corrected equipment description
- S18 Booster Compressor, added equipment that will come on-line as part of the atmospheric PRD removal project (A/N 19163)
- Delete row for fuel gas system (per A/N 19163)
- Modify note 1 for clarification
- Modify note 2 to correct per BWON A/N 19631/19643
- Add Notes 3 and 4 per BWON A/N 19631/19643
- Renumber note 5, was Note 4
- Revise note 5 for deletion of BAAQMD and SIP 8-28 (per A/N 19163)
- Renumber note 6, was Note 5. Correct to remove Regulation 8, Rule 28
- Add Notes 7 and 8 for clarification

Table IV-X1 (Fugitive Components)

- Renumber, was Table IV-AN
- Regulation 8, Rule 18
 - Roll up applicability for 8-18-304, 8-18-306 - clarification
 - Add 8-18-308 – add applicable citation
- BAAQMD and SIP Regulation 8, Rule 28, remove and move to new Table VII-X2
- 40 CFR, Part 60 Subpart VV, revise to reflect that applicability is driven by other regulations.
- Add Regulations
 - 40 CFR, Part 60 Subpart VVa (new)
 - 40 CFR, Part 60 Subpart GGG (correct omission)
 - 40 CFR, Part 60 Subpart GGGa (new)
- 40 CFR, Part 61 Subpart FF requirements
 - Add description to title row
 - Delete requirements that do not apply to the facility per BWON A/N 19631/19643
 - Add requirements for containers – correct omissions
 - Add delay of repair requirements – correct omissions
 - Correct descriptions for clarification
- 40 CFR, Part 63 Subpart CC requirements
 - Delete 63.648(b) – past effective date
 - Add 63.648(g), (h), and (i) – add applicable requirements
 - Correct descriptions for clarification
- Condition 1240, Part II.32d, delete per A31/S24 A/N 19384/19635
- Condition 1240, Part II.53, delete per A31/S24 A/N 19384/19635
- Condition 1240.Part II.86, delete per A31/S24 A/N 19384/19635

Table IV-X (A17) – Added table per A/N 21641

Table IV-Y (A4) – Table deleted, A4 archived per A/N 21641

Table IV-Z (A31)

- Renumber, was Table IV-AP
- Regulation 1, correct effective date
- Regulation 8, Rule 8 and SIP Regulation 8, Rule 8 requirements
 - Correct description of 8-8-301.3 for clarification
 - Add 8-8-305 and 8-8-305.2 requirements for S27 and S67 per BWON A/N 19631/19643
- 40 CFR, Part 60 Subpart A – delete because redundant with Table IV-A
- 40 CFR, Part 60 Subpart Kb – add description to title row
- 40 CFR, Part 60 Subpart UU requirements
 - 40 CFR, Part 60.470(a) and (b), 60.474(c)(5) – add applicable citations
- 40 CFR, Part 61 Subpart FF requirements – delete per BWON A/N 19631/19643
- Condition 1240 requirements
 - Modify descriptions for clarification
 - Part II.10, delete per BWON A/N 19631/19643
 - Part II.32a, add additional abated sources and BACT to basis per A31/S24 A/N 19384/19635
 - Parts II.32b, II.32c, II.43, II.44, II. 53, II.55, II.56, II.57, II.66, II.67, II.69, II.70, II.85, II.86, delete per A31/S24 A/N 19384/19635
 - Part II.58b, correct per BWON A/N 19631/19643
 - Part II.59c, d, e, f, add per A31/S24 A/N 19384/19635

Table IV-AA (S71)

- Renumber, was Table IV-AQ
- Corrected 9-8-110.4 to 9-8-110.5 for consistency with updated rule
- Incorporate rule update for BAAQMD 9-8
- Add CARB ATCM for stationary diesel engines based on most recent version of ATCM, including addition of rule effective date
- Condition 22928, Parts 1, 2, and 3, updated basis per most recent version of ATCM

V. Schedule of Compliance

A schedule of compliance is required in all Title V permits pursuant to BAAQMD Regulation 2-6-409.10 which provides that a major facility review permit shall contain the following information and provisions:

“409.10 A schedule of compliance containing the following elements:

- 10.1 A statement that the facility shall continue to comply with all applicable requirements with which it is currently in compliance;
- 10.2 A statement that the facility shall meet all applicable requirements on a timely basis as requirements become effective during the permit term; and
- 10.3 If the facility is out of compliance with an applicable requirement at the time of issuance, revision, or reopening, the schedule of compliance shall contain a plan by which the facility will achieve compliance. The plan shall contain deadlines for each item in the plan. The schedule of compliance shall also contain a requirement for submission of progress reports by the facility at least every six months. The progress reports shall contain the dates by which each item in the plan

was achieved and an explanation of why any dates in the schedule of compliance were not or will not be met, and any preventive or corrective measures adopted.”

Since the District has not determined that the facility is out of compliance with an applicable requirement, the schedule of compliance for this permit contains only sections 2-6-409.10.1 and 2-6-409.10.2.

The BAAQMD Compliance and Enforcement Division has conducted a review of compliance over the past year and has no records of compliance problems at this facility during the past year. The compliance report is contained in Appendix A of this permit evaluation and statement of basis.

Changes to permit:

VI. Permit Conditions

During the Title V permit development, the District has reviewed the existing permit conditions, deleted the obsolete conditions, and, as appropriate, revised the conditions for clarity and enforceability. Each permit condition is identified with a unique numerical identifier, up to five digits.

When necessary to meet Title V requirements, additional monitoring, recordkeeping, or reporting requirements have been added to the permit.

All changes to existing permit conditions are clearly shown in “strike-out/underline” format in the proposed permit. When the permit is issued, all “strike-out” language will be deleted and all “underline” language will be retained, subject to consideration of comments received.

The existing permit conditions are derived from previously issued District Authorities to Construct (A/C) or Permits to Operate (P/O). Permit conditions may also be imposed or revised as part of the annual review of the facility by the District pursuant to California Health and Safety Code (H&SC) § 42301(e), through a variance pursuant to H&SC § 42350 et seq., an order of abatement pursuant to H&SC § 42450 et seq., or as an administrative revision initiated by District staff. After issuance of the Title V permit, permit conditions will be revised using the procedures in Regulation 2, Rule 6, Major Facility Review.

Conditions that are obsolete or that have no regulatory basis have been deleted from the permit.

Conditions have also been deleted due to the following:

- Redundancy in recordkeeping requirements.
- Redundancy in other conditions, regulations and rules.
- The condition has been superseded by other regulations and rules.
- The equipment has been taken out of service or is exempt.
- The event has already occurred (i.e. initial or start-up source tests).

The regulatory basis is listed following each condition. The regulatory basis may be a rule or regulation. The District is also using the following terms for regulatory basis:

- BACT: This term is used for a condition imposed by the Air Pollution Control Officer (APCO) to ensure compliance with the Best Available Control Technology in Regulation 2-2-301.
- Cumulative Increase: This term is used for a condition imposed by the APCO that limits a source's operation to the operation described in the permit application pursuant to BAAQMD Regulation 2-1-403.
- Offsets: This term is used for a condition imposed by the APCO to ensure compliance with the use of offsets for the permitting of a source or with the banking of emissions from a source pursuant to Regulation 2, Rules 2 and 4.
- PSD: This term is used for a condition imposed by the APCO to ensure compliance with a Prevention of Significant Deterioration permit issued pursuant to Regulation 2, Rule 2.
- TRMP: This term is used for a condition imposed by the APCO to ensure compliance with limits that arise from the District's Toxic Risk Management Policy.

Changes to permit:

1240 – multiple parts

- Revise H-3, H-6, and H-7 wherever they appear to be H-4603, H-4606, and H-4607, respectively
- Update reference to BAAQMD toxics table location from Table 2-1-316 to Table 2-5-1.

1240 – multiple parts affected by the atmospheric PRD removal project (A/N 19194)

- Intro, added comment for atmospheric PRD removal project
- Part I Title block, add “or without” to allow applicability of the permit condition prior to and after startup
- Part I.3, revised per A/N 19194
- Parts I.5, I.5a, and I.5b, revised per A/N 19194
- Part I.11, revised per A/N 19194
- Parts I.12 and I.13, deleted per A/N 19194
- Part I.16a, revised source test submittal date from 45 to 60 days during Title V permit renewal review
- Part II.6, deleted per A/N 19194

1240 – multiple parts affected by A/N 21641 for archiving S14, S15, and A4 is replaced by A17

- Intro, added comment for A/N 21641
- Part I.18d, delete S15
- Part I.18g, replace A4 with A17
- Part I.18i, replace A4 with A17
- Parts I.19, II.8, II.62 Intro, II.65, and II.68, revised language per A/N 21641
- Parts I.19d and 19e, added per A/N 21641
- Parts II.59, II.60, II.61, II.62, II.62a, II.62b, II.63, II.64a, and II.64b, deleted per A/N 21641

1240 – source descriptions

- Revise descriptions for S3, S5, S6, S7, S8, S13, S31, S37, S38, S51, S52, S53, S54, S59, S60, S61, S62, S63, S65, S66, and S70 to include requirement for abatement by A31. If A31 and the vapor recovery blower are inoperative, emissions must be contained in the closed vent system or vented to S24. A31/S24 A/N 19384/19635.

1240.I.18d

- Remove S14, source has been demolished.

1240.I.18e

- Remove S12, S25, S26, and S28 per BWON A/N 19631/19643.

1240.I.19c

- Add Part 19c to clarify the temperature excursion, which refers only to temperature below the limit.

1240.II.10

- Delete condition based on removal of S25 per BWON A/N 19631/19643.

1240.II.32a

- Revise condition to specify A31 POC collection and destruction efficiency whenever storing or transferring materials at specified sources. A31/S24 A/N 19384/19635.

1240.II.32b

- Deleted, combined with 1240.II.32a. A31/S24 A/N 19384/19635

1240.II.32c

- Deleted, combined with 1240.II.32a. A31/S24 A/N 19384/19635

1240.II.32d

- Delete permit condition because BAAQMD 8-18 does not apply to systems under negative pressure per A31/S24 A/N 19384/19635

1240.II.43

- Deleted, combined with 1240.II.32a. A31/S24 A/N 19384/19635

1240.II.44

- Delete permit condition because BAAQMD 8-18 does not apply to systems under negative pressure per A31/S24 A/N 19384/19635

1240.II.53

- Delete permit condition because BAAQMD 8-18 does not apply to systems under negative pressure per A31/S24 A/N 19384/19635

1240.II.55

- Deleted, combined with 1240.II.32a. A31/S24 A/N 19384/19635

1240.II.56

- Deleted, combined with 1240.II.32a. A31/S24 A/N 19384/19635

1240.II.57

- Deleted, combined with 1240.II.32a. A31/S24 A/N 19384/19635

1240.II.58b

- Revise to clarify that the minimum combustion zone temperature for H-4607 or H-4603 applies only when emissions are vented to H-4607 or H-4603 per A31/S24 A/N 19384/19635
- Revised comment regarding A/N 12704 and A/N 12236 to reflect that the permit application to establish the minimum operating temperatures had been completed
- Remove “40 CFR, Part 61.354(c)(1); 40 CFR, Part 61.354(c)(4)” from basis and add “(Application 19631/19643 (2009) removed 40 CFR, Part 61 Subpart FF citations from basis. Facility has no sources controlled by A31 or S24 for compliance with 40 CFR, Part 61 Subpart FF.)” per BWON A/N 19631/19643

1240.II.58c

Add new condition for temperature excursion language per A/N 17031

1240.II.58d

Add new condition for temperature excursion language per A/N 17031

1240.II.58e

- Add new condition to clarify that temperature excursion applies only to temperatures below the minimum temperature limit per A31/S24 A/N 19384/19635

1240.II.58f

- Add new condition to clarify conditions for temperature excursions per A31/S24 A/N 19384/19635

1240.II.59, II.59a, II.59b, II.60, II.61a, II.61b and Source description prior to II.59

- Remove conditions and description for S14. Source has been demolished.

1240.II.66

- Deleted, combined with 1240.II.32a. A31/S24 A/N 19384/19635

1240.II.67

- Deleted, combined with 1240.II.32a. A31/S24 A/N 19384/19635

1240.II.69

- Deleted, combined with 1240.II.32a. A31/S24 A/N 19384/19635

1240.II.70

- Deleted, combined with 1240.II.32a. A31/S24 A/N 19384/19635

1240.II.85

- Deleted, combined with 1240.II.32a. A31/S24 A/N 19384/19635

1240.II.86

- Delete permit condition because BAAQMD 8-18 does not apply to systems under negative pressure per A31/S24 A/N 19384/19635

1240.II.93

- Add new permit condition per A/31/S24 A/N 19384/19635

1240.II.94

- Add new permit condition per A/31/S24 A/N 19384/19635

19329

- Removed S19 from condition because it is subject to NSR and therefore not subject to NOx box condition
- Added comment that condition be deleted upon expiration of NOx IERCs from Facility B2626

20278.3

- Revise condition to clarify that emissions be contained in the vapor recovery system when the blower is not operating per A31/S24 A/N 19384/19635

21233

- Changed federal enforceability to N based on recent adoption of BAAQMD 9-10 into SIP
- Removed S19 from condition Parts 1 and 5A because it is subject to NSR and therefore not subject to NOx box condition

22851

- Add boilerplate ATCM condition 22851 for firewater pump S-68

22928

- Updated basis to reflect current version of ATCM

VII. Applicable Limits and Compliance Monitoring Requirements

This section of the permit is a summary of numerical limits and related monitoring requirements for each source. The summary includes a citation for each monitoring requirement, frequency of monitoring, and type of monitoring. The applicable requirements for monitoring are completely contained in Sections IV, Source-Specific Applicable Requirements, and VI, Permit Conditions, of the permit.

The District has reviewed all monitoring and has determined the existing monitoring is adequate with the following exceptions.

The tables below contain only the limits for which there is no monitoring or inadequate monitoring in the applicable requirements. The District has examined the monitoring for other limits and has determined that monitoring is adequate to provide a reasonable assurance of compliance. Calculations for potential to emit will be provided in the discussion when no monitoring is proposed due to the size of a source.

Monitoring decisions are typically the result of a balancing of several different factors including: 1) the likelihood of a violation given the characteristics of normal operation, 2) degree of variability in the operation and in the control device, if there is one, 3) the potential severity of impact of an undetected violation, 4) the technical feasibility and probative value of indicator monitoring, 5) the economic feasibility of indicator monitoring, and 6) whether there is some other factor, such as a different regulatory restriction applicable to the same operation, that also provides some assurance of compliance with the limit in question.

These factors are the same as those historically applied by the District in developing monitoring for applicable requirements. It follows that, although Title V calls for a re-examination of all monitoring, there is a presumption that these factors have been appropriately balanced and incorporated in the District's prior rule development and/or permit issuance. It is possible that, where a rule or permit requirement has historically had no monitoring associated with it, no monitoring may still be appropriate in the Title V permit if, for instance, there is little likelihood of a violation. Compliance behavior and associated costs of compliance are determined in part by the frequency and nature of associated monitoring requirements. As a result, the District will generally revise the nature or frequency of monitoring requirements only when it can support a conclusion that existing monitoring is inadequate.

Changes to permit:

A note has been added at the beginning of the section to clarify that this section is a summary of the limits and monitoring, and that in the case of a conflict between Sections I-VI and Section VII, the preceding sections take precedence.

The following regulations have been updated throughout Section VII:

- BAAQMD Regulation 6, Rule 1 - Particulate Matter and Visible Emissions;
- BAAQMD Regulation 8, Rule 5 - Organic Compounds, Storage of Organic Liquids;
- SIP Regulation 8, Rule 5 - Organic Compounds, Storage of Organic Liquids;
- 40 CFR, Part 60 Subpart J – Standards of Performance for Petroleum Refineries

Revise source description in table headers to include full facility equipment numbering IDs in 46xx format.

Made editorial corrections throughout Section VII, including deletion of “#” and “BAAQMD” for all references to BAAQMD permit conditions

Table VII-A

- Move BAAQMD Regulation, 8, Rule 10 from Table VII-L for S-18 to Table VII-A because process vessels are located throughout the facility, not only in the crude unit
- BAAQMD and SIP 9-1-313.2, revised to reference the Facility B2626 H2S CEM monitoring requirement in Conditions 125 and 126, Part 2 because refinery fuel gas generated at BAP is routed and treated at Facility B2626
- 40 CFR, Part 61 Subpart FF (Benzene Waste NESHAP) requirements, revise monitoring requirements per BWON A/N 19631/19643
 - Add monitoring requirements for naphtha lines
 - Remove Benzene Waste NESHAP Reports – these are not monitoring requirements
- 40 CFR, Part 63 Subpart CC (Refinery MACT) requirements.
 - Remove MACT Reports – these are not monitoring requirements

Table VII-B (S1, S2, S4, S23)

- Remove remaining table header. Sources transferred to Facility B5574 and table rows deleted in Revision 2

Table VII-B (S3)

- Renumber, was Table VII-C
- Multiple rows, revise monitoring requirement to be “Temperature CPMS”.
- BAAQMD Regulation 8, Rule 5, add applicable monitoring requirements to correct omission
- Condition 1240, Part II.32a, II.94, add per A31/S24 A/N 19384/19635
- Condition 1240, Part II.43, II.44, delete per A31/S24 A/N 19384/19635
- Condition 20762, add applicable monitoring requirements

Table VII-C (S5, S6, S7, S8, S37, S38, S51, S52, S53, S60, S61, S62, S65)

- Consolidate Tables VII-D (S5, S6, S7, S8, S37, S38), VII-AB (S51, S52, S53, S60), VII-AE (S61, S62), and VII-AG (S65) and renumber as Table IV-C. These sources have similar monitoring requirements. Permit condition differences between the sources are noted.
- Multiple rows, revise monitoring requirement to be “Temperature CPMS”.
- BAAQMD and SIP Regulation 8, Rule 5, add applicable monitoring requirements
- 40 CFR, Part 60.472(c) monitoring requirement, add 60.474(c)(5) as monitoring requirement citation
- Condition 1240, Part II.32a, II.93, II.94, II.95, add conditions per A31/S24 A/N 19384/19635
- Condition 1240, Parts II.93, and II.94, add per A31/S24 A/N 19384/19635
- Condition 20762, add applicable monitoring requirements

Table VII-D (S9)

- Renumber, was Table VII-E
- BAAQMD and SIP Regulation 8, Rule 5

- Revise monitoring requirements to be consistent with Valero B2626 Title V permit format
- Delete monitoring requirement for SIP 8-5-322.3 for old style secondary seal gaps because tank has zero gap secondary seals (subject to 8-5-322.5).
- 40 CFR, Part 63 Subpart CC; 40 CFR, Part 61 Subpart FF; and 40 CFR, Part 60 Subpart Kb, revise 40 CFR, Part 60 Subpart Kb monitoring requirements to include correct references to applicable requirements in 40 CFR, Part 63 Subpart CC and 40 CFR, Part 61 Subpart FF (per BWON A/N 19631/19643) and to be consistent with Valero B2626 Title V permit format

Table VII-E (S12, S26, S28)

- Add description to Title Block
- Consolidate Tables VII-F (S12), VII-Q (S26 and S28) and renumber as Table VII-E. These sources have similar monitoring requirements. Permit condition differences between the sources are noted.
- 40 CFR, Part 61 Subpart FF, delete all monitoring requirements per BWON A/N 19631/19643
- 40 CFR, Part 63 Subpart CC requirements, add applicable requirements for Group 2 tank per BWON A/N 19631/19643
- Condition 20762, add applicable monitoring requirements

Table VII-F (S13, S59, S63)

- Add description to Title block
- Consolidate Tables VII-G (S13), VII-AC (S59), VII-AE (S63) and renumber as Table VII-F. These sources have similar monitoring requirements. Permit condition differences between these sources are noted.
- Multiple rows, revise monitoring requirement to be “Temperature CPMS”.
- Condition 1240, Parts II.32a; clarify that 98.5% destruction of vapors only applies whenever petroleum and VOC materials are stored per A31/S24 A/N 19384/19635
- Condition 1240, Parts II.93, II.94, II.95, add conditions per A31/S24 A/N 19384/19635

Table VII-H (S14) - Delete entire table. S14 has been demolished per A/N 21641.

Table VII-G (S15) – Deleted because S15 removed from service and archived per A/N 21641

Table VII-H (S16) – Renumber, was Table VII-J

Table VII-I (S17)

- Renumber, was Table VII-K
- Added rows for SIP 6-301 and SIP 6-310
- Multiple rows, revise monitoring requirement to be “Temperature CPMS”.

Table VII-J.1 (S18) – Deleted and replaced with Table VII-I per A/N 19194

Table VII-I (S18) (NEW – upon startup of atmospheric PRD removal project)

- Added new table to reflect revised applicability and permit conditions upon startup of the atmospheric PRD removal project (A/N 19194)
 - Delete BAAQMD Regulation, 8, Rule 10 from Table VII-I for S-18 and move to Table VII-A because process vessels are located throughout the facility, not only in the crude unit
 - 40 CFR, Part 63, Subpart CC requirements for Miscellaneous Process Vents, deleted regulation
 - Condition 1240, Part I.3, removed because no longer applicable and replacement condition does not have any monitoring requirements

Table VII-K.1 (S19) – Deleted and replaced with Table VII-J per A/N 19194

Table VII-J (S19) (NEW – upon startup of atmospheric PRD removal project)

- Added new table to reflect revised applicability and permit conditions upon startup of the atmospheric PRD removal project (A/N 19194)
 - BAAQMD Regulation 2, Rule 9, BAAQMD Regulation 9, Rule 10, Condition 19329, and Condition 21233, deleted because S19 is subject to NSR therefore NOx box condition, Reg 2-9, and Reg 9-10 do not apply
 - NSPS Subpart J and Condition 1240 Parts I.11, I.12 and I.13, deleted because NSPS J fuel gas H2S limit and monitoring will no longer apply
 - 40 CFR, Part 63 Subpart CC, deleted because miscellaneous process vent abatement requirements no longer apply
 - Condition 1240.I.3, deleted because S19 requirement to abate S18 offgas will no longer apply
 - Conditions 1240.I.5, 1240.I.5a, and 19329.1 for Throughput, revised monitoring requirement to indicate “fuel flow CPMS”.

Table VII-L (S20)

- Renumber, was Table VII-N
- Conditions 1240.I.5 and 19329.1 for Throughput, revised monitoring requirement to indicate “fuel flow CPMS”.

Table VII-M (S21)

- Renumber, was Table VII-O
- Conditions 1240.I.5 and 19329.1 for Throughput, revised monitoring requirement to indicate “fuel flow CPMS”.

Table VII-N (S24)

- Renumber, was Table VII-P
- Multiple rows, revise monitoring requirement to be “Temperature CPMS”.
- Multiple rows, revise monitoring requirement to be “Temperature CPMS”.
- Regulation 8, Rule 8 and SIP Regulation 8, Rule 8 requirements
 - Add 8-8-305.2 monitoring requirements for S27 and S67 per BWON A/N 19631/19643

- 40 CFR, Part 60 Subpart UU requirements - for 60.472(c), add 60.474(c)(5) as monitoring requirement citation
- 40 CFR, Part 61 Subpart FF requirements – delete per BWON A/N 19631/19643
- Condition 1240 requirements
 - Parts II.32a, clarify that 98.5% destruction of vapors only applies whenever petroleum and VOC materials are stored or transferred per A31/S24 A/N 19384/19635
 - Parts II.32b and II.32c (on the row for Part II.32a), delete per A31/S24 A/N 19384/19635
 - Parts II.32d, II. 43, II.44, II.53, II.55, II.56, II.57, II.70, II.85, II.86, delete per A31/S24 A/N 19384/19635

Table VII-Q (S25, S28) – Delete table

- Delete S25 per BWON A/N 19631/19643
- Move S28 to Table VII-E

Table VII-R (S26) – Delete table and move source to Table VII-E

Table VII-O (S27, S67)

- Consolidate Tables VII-S (S27) and VII-AH (S67) and renumber to Table VII-O. These sources have similar monitoring requirements. Permit condition differences between the sources are noted.
- Multiple rows, revise monitoring requirement to be “Temperature CPMS”.
- Regulation 8-5 and SIP 8-5, delete per BWON A/N 19631/19643
- Regulation 8-8 and SIP 8-8, add per BWON A/N 19631/19643
- 40 CFR, Part 61 Subpart FF, delete per BWON A/N 19631/19643

Table VII-P (S31)

- Renumber, was Table VII-V
- Multiple rows, revise monitoring requirement to be “Temperature CPMS”.
- Condition 1240 requirements
 - Parts II.32a, II.94, II.95, add per A31/S24 A/N 19384/19635
 - Part II.69, delete per A31/S24 A/N 19384/19635

Table VII-Q (S34) Renumber, was Table VII-W

Table VII-X (S39) – Delete table. Source is permanently out of service

Table VII-Y (S40) – Delete table. Source is permanently out of service

Table VII-R (S41)

- Renumber, was Table VII-Z
- Multiple rows, revise monitoring requirement to be “Temperature CPMS”.
- 40 CFR, Part 61 Subpart FF, delete all requirements per BWON A/N 19631/19643
- Regulation 8, Rule 8, add monitoring requirements for 8-8-303

- Condition 1240, Part II.32a, II.58b, II.93, II.95, add per A31/S24 A/N 19384/19635

Table VII-AA (S51, S52, S53, S60) – Delete table and move sources to Table VII-C

Table VII-S (S54)

- Renumber, was Table VII-AB
- Condition 1240 requirements
 - Part II.32a, II.94, II.95, add per A31/S24 A/N 19384/19635
 - Part II.70, delete per A31/S24 A/N 19384/19635

Table VII-AC (S59) – Delete table and move source to Table VII-F

Table VII-AD (S61, S62) – Delete table and move sources to Table VII-C

Table VII-AE (S63) – Delete table and move source to Table VII-F

- Condition 1240, Part II.32d, delete per A31/S24 A/N 19384/19635

Table VII-AF (S65) – Delete table and move source to Table VII-C

- Condition 1240, Part II.53, delete per A31/S24 A/N 19384/19635

Table VII-T (S66)

- Add description to Title block
- Renumber, was Table VII-AG
- Regulation 8, Rule 8, add monitoring requirement for 8-8-303
- 40 CFR, Part 61 Subpart FF requirements, delete all monitoring requirements per BWON A/N 19631/19643
- Condition 1240 requirements
 - Part II.85, II.86, delete per A31/S24 A/N 19384/19635
 - Part II.32a, II. 58b, II.93, II.95, add per A31/S24 A/N 19384/19635

Table VII-AH (S67) – Delete table and move source to Table VII-O

Table VII-U (S68)

- Renumber, was Table VII-AI
- Regulation 9, Rule 8, Updated applicability and monitoring requirements
- CCR, Title 17, Section 93115, add ATCM monitoring requirements
- Condition 22851, add monitoring and recordkeeping requirements

Table VII-V (S69) – Renumber, was Table VII-AJ

Table VII-W (S70)

- Renumber, was Table VII-AK
- Condition 1240, Parts II.32a, II.94, II.95, add per A31/S24 A/N 19384/19635

Table VII-X1 (Components)

- Renumber, was Table VII-AL
- BAAQMD and SIP Regulation 8, Rule 28, remove and move to new Table VII-X2
- 40 CFR, Part 60 Subpart UU – for 60.472(c), add 60.474(c)(5) as monitoring requirement citation
- Condition 1240, Parts II.32d, II.44, II.53 II.86 delete per A31/S24 A/N 19384/19635

Table VII-Y (A4) – Table deleted, A4 replaced with A17 per A/N 21641

Table VII-X (A17) – New table, A17 replaced A4 per A/N 21641

- Multiple rows, revise monitoring requirement to be “Temperature CPMS”.
- 40 CFR, Part 60 Subpart VV, delete 60.480 because Subpart VV compliance is required by other regulations
- Condition 1240 Part II.60 for S14, delete because S14 has been demolished

Table VII-Z (A31)

- Renumber, was Table VII-AP
- Multiple rows, revise monitoring requirement to be “Temperature CPMS”.
- 40 CFR, Part 60 Subpart UU – for 60.472(c), add 60.474(c)(5) as monitoring requirement citation
- BAAQMD and SIP Regulation 8, Rule 8, add 8-8-305.2 monitoring requirements for S27 and S67 per BWON A/N 19631/19643
- 40 CFR, Part 61 Subpart FF requirements – delete per BWON A/N 19631/19643
- Condition 1240 requirements
 - Part I.14, delete row requiring temperature monitoring – correct error
 - Parts II.32a, clarify that 98.5% destruction of vapors only applies whenever petroleum and VOC materials are stored or transferred per A31/S24 A/N 19384/19635
 - Parts II.32c and II.32d (on row for Part II.32a), delete per A31/S24 A/N 19384/19635
 - Parts II.32d, II.43, II.44, II.53, II.55, II.56, II.57, II.85, II.86, II.69, II.70, delete per A31/S24 A/N 19384/19635
 - Part II.59c, d, e, f, add per A31/S24 A/N 19384/19635

Table VII-AA, S71 Emergency Diesel Engine

- Renumber, was Table VII-AQ
- Regulation 9, Rule 8, Updated applicability and monitoring requirements
- CCR, Title 17, Section 93115, add ATCM monitoring requirements
- Condition 22928, add monitoring and recordkeeping requirements

VIII. Test Methods

This section of the permit lists test methods that are associated with standards in District or other rules. It is included only for reference. In most cases, the test methods in the rules are source test methods that can be used to determine compliance but are not required on an ongoing basis. They are not “applicable requirements” as defined by Regulation 2-6-202.

If a rule or permit condition requires ongoing testing, the requirement will also appear in Section IV of the permit.

Changes throughout Section VIII

- Add test method citations, applicable definition citations, and monitoring requirement citations that define test methods to applicable requirements
- Correct description of requirement
- Correct description of acceptable test methods

BAAQMD Regulation 6-1

- Update for latest rule change

BAAQMD Regulation 8, Rule 5

- Update for latest rule change
- Add Manual of Procedures, Volume III, Lab Method 13 for Reid Vapor Pressure as allowable test method for vapor pressure determination
- Add test methods for 8-5-303.2 (PV valve vented to vapor recovery or disposal system)
- Add test methods for 8-5-304.6.1 (EFR leaking pontoons)
- Add test methods for 8-7-307.3 (PRDs vented to vapor recovery or disposal system)

BAAQMD Regulation 8, Rule 8

- Add test methods for 8-8-112 exemption
- Add test methods for 8-8-305.2 (OWS or DNF slop oil vessels vented to vapor recovery or disposal system)

BAAQMD Regulation 8, Rule 18

- Add test methods for 8-18-110 and 8-18-113 exemptions

BAAQMD and SIP Regulation 8, Rule 28

- Deleted all test methods per A/N 19194

40 CFR, Part 60 Subpart Kb

- Delete test methods for 60.112b(a)(3)(ii); 113b(b)(4)(i); 113b(b)(4)(ii) that refer to other sections of Subpart Kb and not to specific test methods

40 CFR, Part 60 Subpart VV

- Update for latest rule change
- Consolidate requirements for Leak Inspection Procedures
- Change description for No detectable emission standards to distinguish it from Leak Inspection Procedures
- Add requirements for VOC service determination
- Add requirements for light liquid service determination

40 CFR, Part 60 Subpart VVa

- Add test methods new regulation

40 CFR, Part 61 Subpart FF

- Delete test methods for requirements that are no longer applicable per BWON A/N 19631/19643

Permit Conditions

- Add requirements for vapor pressure determination
- Condition 1240, Parts II.32d, II.44, II.53, II.86, delete BAAQMD 8-18-116 reference because permit conditions have been deleted per A31/S24 A/N 19384/19635

IX. Permit Shield:

The District rules allow two types of permit shields. The permit shield types are defined as follows: (1) A provision in a major facility review permit explaining that specific federally enforceable regulations and standards do not apply to a source or group of sources, or (2) A provision in a major facility review permit explaining that specific federally enforceable applicable requirements for monitoring, recordkeeping and/or reporting are subsumed because other applicable requirements for monitoring, recordkeeping, and reporting in the permit will assure compliance with all emission limits.

The second type of permit shield is allowed by EPA's "White Paper 2 for Improved Implementation of the Part 70 Operating Permits Program." The District uses the second type of permit shield for all streamlining of monitoring, recordkeeping, and reporting requirements in Title V permits. The District's program does not allow other types of streamlining in Title V permits.

This facility previous had the first type of permit shield – see Section 1 below. This facility has the second type of permit shield.

Following is the detail of the permit shields that were requested by the applicant.

1. The following requested permit shields were previously deleted, but their Title blocks left in place. They are being completely deleted in this renewal:

Table IX A – 1
Permit Shield for Non-applicable Requirements
S30, MARINE LOADING DOCK
(DELETED IN REVISION 2, S30 IS NO LONGER IN OPERATION)

Table IX B - 1
Permit Shield for Subsumed Requirements
S1, S2, S4, AND S23, CRUDE STORAGE TANKS
(DELETED IN REVISION 2. OWNERSHIP OF S1, S2, S4, AND S23 TRANSFERRED TO
FACILITY B5574 BY APPLICATION NO. 7980/8915)

2. The following permit shields are allowed with the changes shown to renumber the permit shield and to add new regulation 40 CFR, Part 60 Subpart VVa:

Table IX B – 1
Permit Shield for Subsumed Requirements
COMPONENTS

Subsumed Requirement Citation	Title or Description	Streamlined Requirements	Title or Description
NSPS, 40 CFR, Part 60 Subpart VV 60.482-2(c)	Pump Leak above 10,000 ppm or dripping liquid: First repair attempt before 5 days and repair before 15 days.	BAAQMD 8-18-303	Minimization of pump leak > 500 ppm within 24 hours and repair within 7 days.
NSPS, 40 CFR, Part 60 Subpart VV 60.482-7(d)	Valve Leak above 10,000 ppm: First repair attempt before 5 days and repair before 15 days.	BAAQMD 8-18-302	Minimization of valve leak > 100 ppm within 24 hours and repair within 7 days.
NSPS, 40 CFR, Part 60 Subpart VV, 60.482-7(g)	Allows relief from 60.482.7(a) monitoring if designated as unsafe-to-monitor.	BAAQMD 8-18-404	BAAQMD Regulation 8-18-404 does not allow this relief.
NSPS, 40 CFR, Part 60 Subpart VV, 60.482-7(h)	Allows relief from 60.482.7(a) monitoring if designated as difficult-to-monitor.	BAAQMD 8-18-206	Definition of inaccessible is more stringent. Both 60.482.7(h) and 8-18-401.3 require yearly monitoring for difficult-to-monitor valves.
NSPS, 40 CFR, Part 60 Subpart VV 60.482-9(e)	Allows delay of repair beyond a process unit shutdown under supply circumstances.	BAAQMD 8-18-306	BAAQMD Regulation 8-18-306 does not allow this relief.
NSPS, 40 CFR, Part 60	Alternative compliance plan only requires EPA approval.	BAAQMD 8-18-308	Requires public noticing and EPA approval of alternative

**Table IX B – 1
Permit Shield for Subsumed Requirements
COMPONENTS**

Subsumed Requirement Citation	Title or Description	Streamlined Requirements	Title or Description
Subpart VV 60.484			compliance plan.
NSPS, 40 CFR, Part 60 Subpart VVa 60.482-2a(c)	Pump Leak above 10,000 ppm or dripping liquid: First repair attempt before 5 days and repair before 15 days.	BAAQMD 8-18-303	Minimization of pump leak > 500 ppm within 24 hours and repair within 7 days.
NSPS, 40 CFR, Part 60 Subpart VVa 60.482-7a(d)	Valve Leak above 10,000 ppm: First repair attempt before 5 days and repair before 15 days.	BAAQMD 8-18-302	Minimization of valve leak > 100 ppm within 24 hours and repair within 7 days.
NSPS, 40 CFR, Part 60 Subpart VVa 60.482-7a(g)	Allows relief from 60.482.7(a) monitoring if designated as unsafe-to-monitor.	BAAQMD 8-18-404	BAAQMD Regulation 8-18-404 does not allow this relief.
NSPS, 40 CFR, Part 60 Subpart VVa 60.482-7a(h)	Allows relief from 60.482.7(a) monitoring if designated as difficult-to-monitor.	BAAQMD 8-18-206	Definition of inaccessible is more stringent. Both 60.482.7(h) and 8-18-401.3 require yearly monitoring for difficult-to-monitor valves.
NSPS, 40 CFR, Part 60 Subpart VVa, 60.482-9a(e)	Allows delay of repair beyond a process unit shutdown under supply circumstances.	BAAQMD 8-18-306	BAAQMD Regulation 8-18-306 does not allow this relief.
NSPS, 40 CFR, Part 60 Subpart VVa 60.484a	Alternative compliance plan only requires EPA approval.	BAAQMD 8-18-308	Requires public noticing and EPA approval of alternative compliance plan.

X. Revision History

Changes to permit:

The changes incorporated in this renewal (Application 18289) have been added to Section X – Revision History

XI. Glossary

Changes to permit:

The glossary was not updated.

XII. Appendix A - State Implementation Plan

Changes to permit:

This section has been deleted. The address for EPA's website is now found in Sections III and IV.

D. Alternate Operating Scenarios:

No alternate operating scenario has been requested for this facility.

E. Compliance Status:

An inter-office memorandum from the Director of Compliance and Enforcement, to the Director of Permit Services, presents a review of the compliance record of Site #: A901. The Compliance and Enforcement Division staff has reviewed the records for Valero Benicia Asphalt Plant for the period between September 1, 2004 through August 26, 2009. This review was initiated as part of the District evaluation of an application by Valero Benicia Asphalt Plant for a Title V permit. The BAAQMD compliance report is provided in Appendix A below.

F. Differences between the Application and the Proposed Permit:

The Title V permit application was originally submitted on May 28, 2008. This version is the basis for constructing the proposed renewal Title V permit.

Permit Evaluation and Statement of Basis: Site A0901, Valero Benicia Asphalt Plant, 3001 Park Road, Benicia, CA 94510

APPENDIX A
BAAQMD COMPLIANCE REPORT

COMPLIANCE & ENFORCEMENT DIVISION

Inter-Office Memorandum

August 26, 2009

TO: BRIAN BATEMAN – DIRECTOR OF ENGINEERING *BB*

FROM: KELLY WEE – DIRECTOR OF ENFORCEMENT *KW*

SUBJECT: REVIEW OF COMPLIANCE RECORD OF:

VALERO BENICIA ASPHALT PLANT – SITE# A0901

Background

This review was initiated as part of the District evaluation of an application by Valero Benicia Asphalt Plant (VBAP) for a Title V Permit Renewal. It is standard practice of the Compliance and Enforcement Division to undertake a compliance record review in advance of a renewal of a Title V Permit to Operate. The purpose of this review is to assure that any non-compliance problems identified during the prior five-year permit term have been adequately addressed, or, if non-compliance persists, that a schedule of compliance is properly incorporated into the Title V permit compliance schedule. In addition, the review checks for patterns of recurring violation that may be addressed by additional permit terms. Finally, the review is intended to recommend, if necessary, any additional permit conditions and limitations to improve compliance.

Compliance Review

Staff reviewed VBAP Annual Compliance Certifications for 9/1/2004 to 7/31/09 and found no ongoing non-compliance and no recurring pattern of violations.

Staff also reviewed the District compliance records for VBAP for 1/1/2008 through 08/26/09. During this period VBAP activities known to the District include:

The District issued 2 Notices of Violation.

NOV#	Issue Date	Occur. Date	Regulation	Violation Cleared	Days in Violation	NOV Comments
A49689	09/16/08	06/20/08	2-6-307	06/20/08	1	P/C#1240-2 58b: A-31, therm. oxidizer temp. below 1400°F
A49970	10/30/08	06/12/08	2-6-307	06/12/08	1	P/C#1240-2 58b: A-31, therm. oxidizer temp. below 1400°F

The two violations (A49689 & A49970) listed in the table above were on the H-4607, Thermal Oxidizer (A-31). In both instances the violations were for failing to operate thermal oxidizer, A-31, at a minimum temperature of 1400 degree F during PG&E power outages. An application for condition modification was submitted by VBAP and approved by the District on April, 22, 2008 which incorporates a section for "Allowable Temperature Excursions" (Permit Condition #01240 Part 19a) to clarify any uncontrolled temperature excursions at A-31 below the allowable limits stated in the District permit.

The District did not receive any air pollution complaints alleging VBAP as the source.

The District received 13 notifications for Reportable Compliance Activities (RCA) included inoperative monitors.

RCA#	Type	Date Occur	Clear Date	Comments
05E87	Inop Monitor	03/22/08	03/24/08	H ₂ S Analyzer Repaired
05G21/05G22	Breakdown/Excess	06/12/08	06/12/08	NOV A49970
05G42/05G43	Breakdown/Excess	06/20/08	06/20/08	NOV A49689
05J32/05J36	Breakdown/Excess	10/17/08	10/17/08	No Excess
05K07/05K08	Breakdown/Excess	12/06/08	12/06/08	No Excess
05K11/05K12	Breakdown/Excess	12/08/08	12/08/08	Breakdown Relief Granted
05K78	Breakdown	01/22/09	01/22/09	Breakdown Relief Granted
05L82	Inop Monitor	04/10/09	04/13/09	H ₂ S Analyzer Repaired

There were 6 reported breakdowns and 5 were reported as indicated excess emission events associated with District permit condition (Regulation 2-6-307) limits.

BAP has a vapor recovery system for various fixed roof tanks and the asphalt loading racks located onsite. Under normal operating conditions, two blowers, B-46500 and B-4608, extract vapors from the various permitted sources, which are then drawn into thermal oxidizer, H-4607, for the abatement of hydrocarbons. Per District permit condition (P/C) #1240, Part 2-58b, the facility is to install and properly maintain a continuous temperature monitor and recording device to ensure that thermal oxidizer, A-31, operates, "with a minimum combustion zone temperature of 1400F to maintain 98.5% destruction efficiency."

There are no enforcement agreements, open variances, or open abatement orders for VBAP.

Conclusion

The Compliance and Enforcement Division has made a determination that for the five year period VBAP was in intermittent compliance. There is no evidence of on-going non-compliance and no recurring pattern of violations that would warrant consideration of a Title V permit compliance schedule.

ejg 08-26-09

APPENDIX B
Permit Evaluations
For

- 7123 – S-19 was up-rated from 33 MMBtu/hr to 40 MMBtu/hr
- 17030 – A-31 Incorporate Temperature Excursion Language
- 19193 – Atmospheric PRD Removal
- 19384 – Proposed Changes to Permit Condition A-31 (H4607) Thermal Oxidizer and S-24 (H-4603) Hot Oil Heater
- 19631 – 40 CFR, Part 61, Benzene Waste NESHAPS Revisions
- 21641 – Addition of A17, Archiving of A4, S14, and S15

**ENGINEERING EVALUATION
VALERO BENICIA ASPHALT PLANT
PLANT NO. 13193
APPLICATION NO. 7123**

BACKGROUND

Valero Benicia Asphalt Plant (previously Huntway Refining Company) is asking for an increase in the heat input to the following source:

S19 Vacuum Heater

The burner currently has a limit of 33 MMBtu/hr. Valero is asking for an increase of 7 MMBtu/hr or a total heat input of 40 MMBtu/hr. The vacuum heater is also the abatement device for the vacuum tower's vapor recovery system with a required POC destruction efficiency of 98.5%.

Emission of NO_x is currently limited to 30 ppmvd at 3% O₂ by Regulation 9 Rule 7. Emission of CO is conditionally limited to 140 ppmvd at 3% O₂. When the heater was permitted for the previous heat input increase from 22.4 to 33 MMBtu/hr in May of 2002, the previous owner, Huntway Refining Company, was not subject to BACT since the 'increase' in emissions were less than 10 lb/day. Because the application was submitted prior to May 17, 2002, Huntway was not subject to the amendment of Regulation 2-2-301. The owner/operator of S19 Vacuum Heater will now be subject to BACT since Regulation 2-2-301 now requires that BACT be applied to a modified source with the 'potential' to emit 10.0 lb/day of POC, NPOC, NO_x, SO₂, PM₁₀, or CO versus only a modification 'increase' in emissions of greater than 10 lb/day.

2-2-301 Best Available Control Technology Requirement: An applicant for an authority to construct or a permit to operate shall apply BACT to any new or modified source:

301.1 Which results in an emission from a new source or an increase in emissions from a modified source and which has the potential to emit 10.0 pounds or more per highest day of precursor organic compounds (POC), non-precursor organic compounds (NPOC), nitrogen oxides (NO_x), sulfur dioxide (SO₂), PM₁₀ or carbon monoxide (CO). BACT shall be applied for any of the above pollutants, which meets both criteria.(Amended 6/15/94; 10/7/98; 5/17/00)

EMISSIONS SUMMARY

As described in the 'Background' Section, Valero will now be subject to BACT limits for Refinery Process Heaters, Natural or Induced Draft: 5 MMBtu/hr to < 50 MMBtu/hr Heat Input (Document 94.1.1).

Pollutant	Previous Emission Factors	NEW Emission Factors
NO _x	0.0364 lb/MMBtu at 30 ppmvd at 3% O ₂ (see below for calculation)	0.0303 lb/MMBtu at 25 ppmvd at 3% O ₂ (see below for calculation)
CO	0.1033 lb/MMBtu at 140 ppmvd at 3% O ₂ (see below for calculation)	0.0369 lb/MMBtu at 50 ppmvd at 3% O ₂ (see below for calculation)
POC	0.008 lb/MMBtu*	0.008 lb/MMBtu*
PM ₁₀	0.011 lb/MMBtu*	0.011 lb/MMBtu*

SO2	0.0016 lb/MMBtu (see below for calculation)	0.0016 lb/MMBtu (see below for calculation)
-----	--	--

*The emission factor for POC and PM10 are taken from the application. These factors are more conservative than the AP-42 estimates of 0.0072 lb/MMBtu for PM10 and 0.0052 lb/MMBtu for POC.

Exhaust flow: $(8710 \text{ dscf/MMBtu}) * (21 / (21 - 3)) = 10161.67 \text{ dscf/MMBtu at } 3\% \text{ O}_2$

$$n = PV/RT = (1 \text{ atm} * 10161.67 \text{ dscf/MMBtu}) / ((0.7302 \text{ atm-cf/lb-mol R}) * (68 + 460 \text{ R})) = 26.3566 \text{ lb-mol/MMBtu}$$

Previous Emission Factors:

NOx emission factor: $26.3566 \text{ lb-mol/MMBtu} (30 \text{ lb-mol NO}_x / 1 \text{E}6 \text{ lb-mol}) (46 \text{ lb NO}_x / \text{lb-mol NO}_x) = 0.0364 \text{ lb/MMBtu}$

CO emission factor: $26.3566 \text{ lb-mol/MMBtu} (140 \text{ lb-mol NO}_x / 1 \text{E}6 \text{ lb-mol}) (28 \text{ lb NO}_x / \text{lb-mol NO}_x) = 0.1033 \text{ lb/MMBtu}$

New Emission Factors:

NOx emission factor: $26.3566 \text{ lb-mol/MMBtu} (25 \text{ lb-mol NO}_x / 1 \text{E}6 \text{ lb-mol}) (46 \text{ lb NO}_x / \text{lb-mol NO}_x) = 0.0303 \text{ lb/MMBtu}$

CO emission factor: $26.3566 \text{ lb-mol/MMBtu} (50 \text{ lb-mol NO}_x / 1 \text{E}6 \text{ lb-mol}) (28 \text{ lb NO}_x / \text{lb-mol NO}_x) = 0.0369 \text{ lb/MMBtu}$

The concentration of H2S is fixed at 10 ppm. It is assumed that all sulfur in the refinery fuel gas is in the form of H2S. Assume all fuel sulfur is converted to SO2.

SO2 emission: $(10 \text{ cf H}_2\text{S} / 1 \text{E}6 \text{ cf fuel}) (\text{cf fuel} / 1050 \text{ Btu}) (\text{lb-mol H}_2\text{S} / 397 \text{ cf H}_2\text{S}) X (64 \text{ lb} / \text{lb-mol H}_2\text{S}) (1 \text{E}6 \text{ Btu} / \text{MMBtu}) = 0.0016 \text{ lb/MMBtu}$

Annual Emissions:

The S19 Vacuum Heater will be run 8760 hr/yr.

New Emissions:

NOx = $0.0303 \text{ lb/MMBtu} (40 \text{ MMBtu/hr}) (8760 \text{ hr/yr}) = 10,617.12 \text{ lb/yr} = 5.308 \text{ tpy}$
 CO = $0.0369 \text{ lb/MMBtu} (40 \text{ MMBtu/hr}) (8760 \text{ hr/yr}) = 12,929.76 \text{ lb/yr} = 6.465 \text{ tpy}$
 POC = $0.008 \text{ lb/MMBtu} (40 \text{ MMBtu/hr}) (8760 \text{ hr/yr}) = 2,803.20 \text{ lb/yr} = 1.401 \text{ tpy}$
 PM10 = $0.011 \text{ lb/MMBtu} (40 \text{ MMBtu/hr}) (8760 \text{ hr/yr}) = 3,854.40 \text{ lb/yr} = 1.927 \text{ tpy}$
 SO2 = $0.0016 \text{ lb/MMBtu} (40 \text{ MMBtu/hr}) (8760 \text{ hr/yr}) = 560.64 \text{ lb/yr} = 0.280 \text{ tpy}$

Previous Emissions:

NOx = $0.0364 \text{ lb/MMBtu} (33 \text{ MMBtu/hr}) (8760 \text{ hr/yr}) = 10,522.51 \text{ lb/yr} = 5.261 \text{ tpy}$
 CO = $0.1033 \text{ lb/MMBtu} (33 \text{ MMBtu/hr}) (8760 \text{ hr/yr}) = 29,861.96 \text{ lb/yr} = 14.931 \text{ tpy}$
 POC = $0.008 \text{ lb/MMBtu} (33 \text{ MMBtu/hr}) (8760 \text{ hr/yr}) = 2,312.64 \text{ lb/yr} = 1.156 \text{ tpy}$
 PM10 = $0.011 \text{ lb/MMBtu} (33 \text{ MMBtu/hr}) (8760 \text{ hr/yr}) = 3,179.88 \text{ lb/yr} = 1.590 \text{ tpy}$
 SO2 = $0.0016 \text{ lb/MMBtu} (33 \text{ MMBtu/hr}) (8760 \text{ hr/yr}) = 462.53 \text{ lb/yr} = 0.231 \text{ tpy}$

Increase in Emissions:

NOx = $10,617.12 \text{ lb/yr} - 10,522.51 \text{ lb/yr} = 94.61 \text{ lb/yr} = 0.047 \text{ tpy}$
 CO = $12,929.76 \text{ lb/yr} - 29,861.96 \text{ lb/yr} = -16,932.20 \text{ lb/yr} = -8.466 \text{ tpy}$
 POC = $2,803.20 \text{ lb/yr} - 2,312.64 \text{ lb/yr} = 490.56 \text{ lb/yr} = 0.245 \text{ tpy}$
 PM10 = $3,854.40 \text{ lb/yr} - 3,179.88 \text{ lb/yr} = 674.52 \text{ lb/yr} = 0.337 \text{ tpy}$
 SO2 = $560.64 \text{ lb/yr} - 462.53 \text{ lb/yr} = 98.11 \text{ lb/yr} = 0.049 \text{ tpy}$

Maximum Daily Emissions:

NOx = 0.0303 lb/MMBtu(40 MMBtu/hr)(24 hr/day) = 29.09 lb/day
 CO = 0.0369 lb/MMBtu(40 MMBtu/hr)(24 hr/day) = 35.42 lb/day
 POC = 0.008 lb/MMBtu(40 MMBtu/hr)(24 hr/day) = 7.68 lb/day
 PM10 = 0.011 lb/MMBtu(40 MMBtu/hr)(24 hr/day) = 10.56 lb/day
 SO2 = 0.0016 lb/MMBtu(40 MMBtu/hr)(24 hr/day) = 1.54 lb/day

Plant Cumulative Increase: (tons/year)

Pollutant	Existing		New	Total	0.000	0.047	0.047
		NOx					
CO			5.535	0.000		5.535	
POC			0.000	0.245		0.245	
SO2	0.168	0.049		0.217			
PM10	1.420	0.337		1.757			
NPOC	0.000	0.000		0.000			

Toxic Risk Screening:

The increase in toxic emissions does not exceed the District Risk Screening Trigger and a Risk Screening Analysis is not required (see Appendix A). Toxic emissions were determined using the California Air Toxics Emission Factor (CATEF) Database for a heater fired with natural gas/refinery fuel gas with no air pollution control device. The CATEF database does not have emissions of metals for the firing of heaters. AP-42 has emissions for ‘general’ natural gas fired equipment. When using AP-42, the emission of cadmium at 0.0543 lb/yr is greater than the District Trigger of 0.046 lb/yr. Brian Bateman, Manager of Toxics, recommends using the CATEF emission factors. He noted that even if AP-42 emission factors are used, S19 is expected to pass a Risk Screen since emissions are very low (close to the trigger level) and the equipment is a combustion source, which are usually associated with good dispersion fumes and emission stacks that are located far above ground level. There is also some question as to the confidence and validity of the testing method and detection limits in the AP-42 emission factor for cadmium.

STATEMENT OF COMPLIANCE

The owner/operator of S19 Vacuum Heater shall comply with Reg. 6 (Particulate Matter and Visible Emissions Standards) and Reg. 9-1-301 (Inorganic Gaseous Pollutants: Sulfur Dioxide for Limitations on Ground Level Concentrations). The owner/operator is expected to comply with Regulation 6 since S19 is fueled with natural gas or refinery fuel gas. Thus for any period aggregating more than three minutes in any hour, there should be no visible emission as dark or darker than No. 1 on the Ringlemann Chart (Regulation 6-301) and no visible emission to exceed 20% opacity (Regulation 6-302).

The owner/operator of S19 Vacuum Heater will be conditionally permitted to meet BACT. NOx emissions must not exceed 25 ppmvd at 3% O2 and CO emissions must not exceed 50 ppmvd at 3% O2. The owner/operator meets the requirements of Regulation 9-7-301.1 and 9-7-301.2 since emissions are below 30 ppmvd at 3% O2 for NOx and 400 ppmvd at 3% O2 for CO.

The project is considered to be ministerial under the District's CEQA regulation 2-1-311 and therefore is not subject to CEQA review. The engineering review for this project requires only the application of standard permit conditions and standard emissions factors and therefore is not discretionary as defined by CEQA. (Permit Handbook Chapter 2.4).

The project is over 1000 feet from the nearest school and therefore not subject to the public notification requirements of Reg. 2-1-412.

Best Available Control Technology:

In accordance with Regulation 2, Rule 2, Section 301, BACT is triggered for any new or modified source with the potential to emit 10 pounds or more per highest day of POC, NPOC, NO_x, CO, SO₂ or PM₁₀. Based on the emission calculations above, the owner/operator is subject to BACT for NO_x and PM₁₀. The owner operator will be conditionally permitted to meet BACT 2 for NO_x and CO. Emissions of NO_x will not exceed 25 ppmvd at 3% O₂ and emissions of CO will not exceed 50 ppmvd at 3% O₂. The owner/operator is expected to meet BACT 2 for PM₁₀ since natural gas or treated refinery fuel will be fired.

BACT 1 levels are not determined for CO and PM₁₀. The BACT 1 level for NO_x is 10 ppmvd at 3% O₂ (0.0121 lb/MMBtu) using an SCR with a low NO_x burner. The most recent edition of the EPA's OAQPS Air Pollution Control Cost Manual, Sixth Edition, 2001, has added an entirely new section for NO_x controls. The chapter for SCR controls was updated on 3/3/03 but is only applicable to large industrial boilers with a firing rate greater than 250 MMBtu/hr. Alternatively, the EPA 'NO_x Control Technology Cost Tool' was used. This program is also for boilers but will estimate NO_x control costs for smaller natural gas fired equipment. The following inputs were used:

Equipment Capacity:	(40E6Btu/hr)(0.293 W-hr/Btu)(MW/1E6W) = 11.72 MW
Uncontrolled NO _x :	0.0303 lb/MMBtu
Equipment Capacity:	8760 hrs/yr = 100%

The results of the 'NO_x Control Technology Cost Tool' are attached to this evaluation. The results show that the SCR will abate the NO_x to 0.01 lb/MMBtu at a total cost of \$390,636 per year. For comparison, a vendor quote from Johnson-Matthey for an SCR to abate a natural gas fired IC engine at half the firing rate of S19 running at a capacity of 50% of S19 at the same controlled NO_x emission of 10 ppmvd was \$334,000 (AN 4226).

Emissions at BACT 1 and 2:

BACT 2: 0.0303 lb/MMBtu(40 MMBtu/hr)(8760 hr/yr) = 10,617.12 lb/yr = 5.308 tpy

BACT 1: 0.0121 lb/MMBtu(40 MMBtu/hr)(8760 hr/yr) = 4,239.84 lb/yr = 2.1199 tpy

Emission Reduction = 5.308 tpy – 2.1199 tpy = 3.188 tpy

Cost Effectiveness = \$390,636/3.188 tpy = \$122,533.25 per ton of NO_x

The cost of the SCR abatement device exceeds \$17,500/ton and therefore it is not cost effective to implement abatement (BACT 1) for S19.

Offsets: Valero Benicia Asphalt Plant (PN 13193) is located adjacent to and is owned by the Valero Refining Company (PN 12626). Although these plants have separate plant numbers, they are considered to be the same facility as per Regulation 2-1-213. Therefore, Valero Benicia Asphalt Plant is part of a major facility emitting more than 100 tpy of POC, NO_x, CO, SO₂ and PM₁₀. Federally enforceable offsets must be provided for any new or modified source at a facility that emits more than 50 tons/yr of POC or NO_x. Offsets must be provided for the emission from the new or modified source AND any pre-existing cumulative increase at a 1.15 to 1.0 ratio. Emission credits of POC may be used to offset increased emissions of NO_x as per Regulation 2-2-302.2.

Valero is a Major Facility and must offset emissions of SO₂ and PM₁₀ at a 1.0 to 1.0 ratio. Emission reduction credits of NO_x and/or SO₂ may be used to offset increased emissions of PM₁₀ at ratios determined by the APCO as per Regulation 2-2-303.1. The substitution ratio of SO₂ for PM₁₀ is 4.0 to 1.0 (Shell Refinery Studies).

Valero would like to offset NO_x with POC credits and PM₁₀ with SO₂ credits. They will provide Certificate #818 with 6.326 tpy for POC and Certificate #838 with 9.932 tpy for SO₂. Valero has requested to defer the offsets until their permit renewal date (May 1st, 2003) as permitted in Regulation 2-2-421. Valero has provided the District with Banking Certificates #818 and #838 and therefore meets the requirements of Regulation 2-2-421.1. The cumulative increases are less than 15 tpy, which meets the requirement of Regulation 2-2-421.2.

Permit Evaluation and Statement of Basis: Site A0901, Valero Benicia Asphalt Plant, 3001 Park Road, Benicia, CA 94510

Offset Calculations:

NOx: 0.047 tpy(1.15 offset ratio) = 0.054 tpy NOx to offset with 0.054 tpy from POC certificate
POC: 0.245 tpy(1.15 offset ratio) = 0.281 tpy POC to offset with 0.281 tpy from POC certificate
SO2: 0.217 tpy (1.00 offset ratio) = 0.217 tpy SO2 to offset with 0.217 tpy from SO2 certificate
PM10: 1.757 tpy(1.00 offset ratio) = 1.757 tpy PM10(4.0 substitution ratio for SO2) = 7.028 tpy from SO2 certificate

Certificate #818: 6.326 tpy POC available – 0.054 tpy – 0.281 = 5.991 tpy POC remaining

Certificate #838: 9.932 tpy SO2 available – 0.217 tpy – 7.028 tpy = 2.687 tpy SO2 remaining

Standards of Performance for New Stationary Sources (NSPS):

Title 40 CFR Part 60 Subpart J contains the NSPS for fuel gas combustion devices in refineries.

S19 Vacuum Heater is conditionally subject to a fuel gas H2S concentration limit of 10 ppmvd prior to mixing averaged over any consecutive 24-hr period (or 163 ppmvd prior to mixing averaged over any consecutive 3 hr period) and therefore meets the limitation of 230 mg/dscm (168 ppmvd) in the NSPS. Valero scrubs the H2S from the fuel gas and monitors the H2S concentration with a CEM.

National Emission Standards for Hazardous Air Pollutants (NESHAPS):

Title 40 CFR Part 63 Subpart CC contains the NESHAPS for miscellaneous process vents. The

S19 Vacuum Heater is also the abatement device for the vacuum tower's vapor recovery system with a required POC destruction efficiency of 98.5%. Valero is conditionally permitted to reduce HAP's by 98% or 20 ppmvd @ 3% O2 as required by 40 CFR 63.643 (2). The vent stream is introduced in the flame device of the S19 Vacuum Heater and exempt from monitoring as per 40 CFR 63.644(a) and 40 CFR 63.645.

PSD does not apply.

PERMIT CONDITIONS

Amendments to Condition 1240:

BAAQMD Condition ID # 1240

Pursuant to permit application #7123 (March, 2003) the total refinery wide heat input has been corrected from 86.6 to 93.6 MMBTU/HR, and the allowable heat input for S19 was increased from 33 to 40 MMBtu/hr.

I. REFINERY CONDITIONS – (Valero Benicia Asphalt Plant)

S-18 Crude Unit with Vacuum Distillation Column vented to and abated by S19 Vacuum H-1

5. The maximum heat input to all refinery combustion units shall not exceed a total of ~~86.6~~ 93.6 MM BTU/Hr. Compliance will be determined from the daily reading of the PG&E natural gas flow meter. These meter readings shall be logged and initialed by the operations coordinator on a daily basis. These readings and the monthly PG&E bills shall be made available to the District upon request.

(Cumulative increase, BACT)

5a. The maximum heat input to S19, Vacuum Heater, shall not exceed ~~33~~ 40 MMBtu/hr.

(Cumulative increase, BACT)

5b. CO emissions in the exhaust of S19, Vacuum Heater, shall not exceed ~~140~~ 50 ppmvd at 3% oxygen over any one-hour period.

(Cumulative increase, BACT)

5c. CO emissions in the exhaust of S19, Vacuum Heater, shall not exceed ~~3.4~~ 1.47 lb/hr over any one-hour period.

(Cumulative increase, BACT)

8. Vacuum Heater (S19) shall be equipped with a John Zink LoNOx Burner. Average NOx emissions from S19 shall not exceed ~~30~~ 25 ppm corrected to 3% oxygen on a dry basis (one hour averaging period).

(Cumulative Increase, BACT)

14. Total refinery emissions (excluding marine emissions) shall not exceed the limits listed below:

a. Non-Methane Hydrocarbons	49.1	49.345 tons/yr
b. Sulfur Dioxide	28	28.049 tons/yr
c. Nitrogen Oxides, as NO2	40	40.047 tons/yr

(Cumulative Increase)

16. The permit holder shall perform a source test at S19, Vacuum Heater, every 24 months to determine compliance with the NOx and CO standards in Regulation 9, Rule 10, and the NOx limit in part 8 of this condition, and the CO limit in part 5b of this condition, and the requirement for 98.5% POC destruction efficiency. The source test shall be performed at a minimum of 85% the maximum capacity of 33 40 MMBtu/hr (34 to 40 MMBtu/hr). All source testing shall be done in accordance with the District's Manual of Procedures. The facility shall receive approval from the District's Source Test Manager for installation of test ports and source testing procedures. The results shall be delivered to the District no later than 30 days from the date of the source test.

(Regulation 9-10-301, 9-10-305, Cumulative Increase, BACT)

A/C Conditions (to be deleted after completion):

17. Within 60 days of issuance of the authority to construct for application #7123, the permit holder shall perform a source test at S19, Vacuum Heater, to determine compliance with the NOx limit in part 8 of this condition, the CO limit in part 5b of this condition, and compliance with the requirement for 98.5% POC destruction efficiency. The source test shall be performed at the maximum capacity of 40 MMBtu/hr. All source testing shall be done in accordance with the District's Manual of Procedures. The facility shall receive approval from the District's Source Test Manager for installation of test ports and source testing procedures. The results shall be delivered to the District no later than 30 days from the date of the source test.

(BACT, Cumulative Increase, Toxics)

Permit Evaluation and Statement of Basis: Site A0901, Valero Benicia Asphalt Plant, 3001 Park Road, Benicia, CA 94510

RECOMMENDATION

Issue an Authority to Construct to the Valero Benicia Asphalt Plant for the following source:

S19 Vacuum Heater – Increase Firing Rate from 33 to 40 MMBtu/hr

EXEMPTIONS

None.

By: _____

Pamela J. Leong
Air Quality Engineer
April 7, 2003

Appendix A

Total Emissions of Hazardous Air Pollutants : CATEF w/ Heater fired with Natural Gas/Refinery gas, no APC Device

HAP	7		8760.0000	
	nat gas	nat gas	nat gas	Trigger Level
	lb/mmcf	lb/mmbtu	lb/yr	lb/yr
Acetaldehyde	1.47E-02	1.44E-05	0.8837	72.0000
Acrolein	2.29E-03	2.25E-06	0.1377	3.9000
benz(a)anthracene	1.80E-06	1.76E-09	0.0001	0.0440
Benzene	2.12E-02	2.08E-05	1.2745	6.7000
Benzo(a)anthracene	9.57E-06	9.38E-09	0.0006	0.0440
Benzo(a)pyrene	6.07E-06	5.95E-09	0.0004	0.0440
benzo(b)fluoranthene	2.63E-06	2.58E-09	0.0002	0.0440
benzo(k)fluoranthene	1.46E-06	1.43E-09	0.0001	0.0440
chrysene	1.24E-06	1.22E-09	0.0001	0.0440
dibenzo(a,h)anthracene	1.38E-07	1.35E-10	0.0000	0.0440
Formaldehyde	4.33E-02	4.25E-05	2.6031	33.0000
indeno(1,2,3-cd)pyrene	6.67E-07	6.54E-10	0.0000	0.0440
Naphthalene	2.31E-03	2.26E-06	0.1389	270.0000
Phenol	1.72E-03	1.69E-06	0.1034	8700.0000
Toluene	2.63E-02	2.58E-05	1.5811	39000.0000
Xylene	3.03E-02	2.97E-05	1.8216	6800.0000

**EVALUATION REPORT
Valero Refining Company – Asphalt Plant
Application #17030- Plant #13193**

**3400 E. Second St.,
Benicia, CA 94510**

I. BACKGROUND

Valero has applied for a condition change to the Permit to Operate for the following equipment:

A-31 Thermal Oxidizer (H-4607), 3.5 MMBtu/hr abate S-3, S-5 thru S-8, S-12, S-13, S-25, S-28, S-31, S-37, S-38, S-41, S-51 thru S-54, S-59, S-60 thru S-63, S-65 thru S-67, and S-70

A-31 thermal oxidizer is currently subject to the requirement of permit Condition 1240, Part II, 58b, which limits the minimum operating temperature to 1400°F to maintain a 98.5% destruction efficiency. This condition does not allow the startup and shutdown periods during which the abatement device may operate below the minimum temperature. In this application, Valero requested to incorporate the District's standard temperature excursion language that was established in the District's Permit Handbook Chapter, Section 4.B into Condition 1240, Part II, 58b, so that it will reflect the startup and shut down operation.

The Thermal Oxidizer is actually listed as downstream of A-1, A-3, A-6, and A-20, which are mist eliminators associated with the controlled sources listed above .

The proposed change is consistent with the District's policy; therefore, the District agreed to allow the condition change. Valero submitted an administrative change to the TV permit concurrently under Application # 17031.

II. EMISSION CALCULATIONS

This application will not result in an emission increase.

III. PLANT CUMULATIVE INCREASE SINCE 4/5/1991

There are no net changes to the plant cumulative emissions.

IV. TOXIC SCREENING ANALYSIS

This application will not result in an increase in toxic air contaminant emissions from existing levels. Therefore, a Toxic RSA is not required.

V. BEST AVAILABLE CONTROL TECHNOLOGY

This application will not result in any emission increase from existing levels. Therefore, BACT is not triggered per Regulation 2-2-301.

VI. OFFSETS

This application does not result in emission increases. Therefore, offsets are not needed per Regulation 2-2-302.

VII. STATEMENT OF COMPLIANCE

All sources of this application are subject and expected to comply with Regulation 1 - General Provisions and Definitions, Regulation 6 - Particulate Matter and Visible Emissions, Regulation 8-5 – Storage of Organic Liquid, Regulation 8-16 – Organic Liquid Bulk Terminals and Bulk Plants, Regulation 8-8 – Wastewater Collection and Separation Systems, Regulation 8-15 – Organic Compounds, Emulsified and Liquid Asphalts.

All sources of this application are subject to and expected to comply with the following Regulation 10: New Source Performance Standards (NSPS), and National Emission Standards for Hazardous Pollutants (NESHAP).

- 40 CFR, Part 60, Subpart Kb - NSPS for Storage Vessels for Petroleum Liquids for which construction, reconstruction or modification commenced After July 23, 1984
- 40 CFR, Part 60, Subpart UU - Standards of Performance for Asphalt Processing
- 40 CFR, Part 60, Subpart FF – Standard for Benzene Waste Operations
- 40 CFR, Part 63, Subpart CC – Petroleum Refining

This project is considered to be categorically exempt under the District's CEQA Regulation 2-1-312.1 and therefore is not subject to CEQA review. This permit application is to change the condition for the existing air pollution control or abatement equipment, which does not involve any increases in emissions or physical modifications.

This project is subject to and expected to be in compliance with the Standard of Performance for New Stationary Sources (NSPS), 40 CFR 60, Subpart J – Standards of Performance for Petroleum Refineries (dated 2/7/02). This abatement may or may not be required to install the H₂S continuous monitoring and recording system to comply with the concentration (dry basis, zero excess air) of 230 mg/dscm (0.1 gr/dscf or 163 ppmv) of H₂S in fuel gases before being burned since the definition of fuel gas has been revised and anticipated to be approved by April 2008.

This project is over 1,000 ft from the nearest public school and is therefore not subject to the public notification requirements of Regulation 2-1-412.

A toxic risk screening analysis is not required.

BACT, PSD, and NESHAPS are not required

CONDITIONS

Condition # 1240 for all sources, amended by Application # 17030

II. TANKAGE AND LOADING RACK CONDITIONS:

58. Separately, for each of S5, S6, S7, S8, S37, S38, S51, S52, S53, S60, S61, S62, S65, and S70, at the conclusion of each month, the permittee shall record, by material name, in a District approved log, the total volume of each liquid material throughput to each tank during that month and during each rolling 12 consecutive month period, in gallon units or barrel units. This log shall be retained for at least 5 years from date of entry, shall be kept on site, and shall be made available to the District staff on request. (cumulative increase)

58a. Deleted Application 17468.

58b. The Owner/Operator shall install and properly maintain continuous temperature monitoring and recording devices for A31, Thermal Oxidizer and S24, Hot Oil Heater. The Owner/Operator shall operate A-31 with a minimum combustion zone temperature of 1400F to maintain a 98.5% destruction efficiency. The Owner/Operator shall operate S-24 at a minimum operating temperature of 1115F to maintain a 98.5% destruction efficiency when S-24 is operated in abatement service. (Source Test Requirements demonstrating compliance with the 98.5% abatement destruction efficiency and the Regulation 6-310 grain loading requirements were completed February 28 and 29, 2004.) (Applications 12704 for A-31 and Application 12236 for S-24 have been submitted for the Title V permit revisions) (Basis: 40 CFR 60.113b(c)(1)(ii) and 60.113b(c)(2); 40 CFR 60.473c; 40 CFR 61.354(c)(1); 40 CFR 61.354(c)(4), Regulation 2-6-409.2.2, 2-6-414)

S14 Naphtha Loading Racks abated by A4 Thermal Oxidizer H-6

58c. The temperature limit in Part II.58b for A-31 shall not apply during an “Allowable Temperature Excursion”, provided that the temperature controller setpoint remains at a minimum of 1,400 °F. An Allowable Temperature Excursion is one of the following:

- a. A temperature excursion not exceeding 20 degrees F; or
- b. A temperature excursion for a period or periods which when combined are less than or equal to 15 minutes in any hour; or
- c. A temperature excursion for a period or periods which when combined are more than 15 minutes in any hour, provided that all three of the following criteria are met.
 - i. the excursion does not exceed 50 degrees F;
 - ii. the duration of the excursion does not exceed 24 hours; and
 - iii. the total number of such excursions does not exceed 12 per calendar year.

Two or more excursions greater than 15 minutes in duration occurring during the same 24-hour period shall be counted as one excursion toward the 12-excursion limit. (basis: Regulation 2-1-403)

58d. For each Allowable Temperature Excursion that exceeds 20 degrees F and 15 minutes in duration, the Permit Holder shall keep sufficient records to demonstrate that they meet the qualifying criteria described above. Records shall be retained for a minimum of five years from the date of entry, and shall be made available to the District upon request. Records shall include at least the following information:

- a. Temperature controller setpoint;
- b. Starting date and time, and duration of each Allowable Temperature Excursion;
- c. Measured temperature during each Allowable Temperature Excursion;
- d. Number of Allowable Temperature Excursions per month, and total number for the current calendar year; and
- e. All strip charts or other temperature records.

(basis: Regulation 2-1-403)

59. S14 shall be operated with a submerged fill pipe and be abated by A4 Thermal Oxidizer H-6 at all times that materials are transferred at S14. (cumulative increase, offsets, BACT, toxics)

IX. RECOMMENDATION

Permit Evaluation and Statement of Basis: Site A0901, Valero Benicia Asphalt Plant, 3001 Park Road, Benicia, CA 94510

Issue a conditional change to the Permit to Operate to Valero Refining Company for the following equipment:

A-31 Thermal Oxidizer (H-4607), 3.5 MMBtu/hr abate S-3, S-5 thru S-8, S-12, S-13, S-25, S-28, S-31, S-37, S-38, S-41, S-51 thru S-54, S-59, S-60 thru S-63, S-65 thru S-67, and S-70

Thu H. Bui
Senior Air Quality Engineer
Permit Services Division
Date: _____

THB:disk-v\ValeroAsphalt\17030e

**EVALUATION REPORT
VALERO REFINING COMPANY
Application #19193 - Plant # A0901**

**3400 East Second St.
Benicia, CA 94510**

I. BACKGROUND

Valero has applied for a change of condition to the Permit to Operate for the following equipment:

Valero Benicia Asphalt Plant (BAP), Facility No. A0901

S-18 Crude Unit

S-19 Vacuum Heater, 40 MMBtu/hr, John Zink, CoolStar low NOx Burner, natural gas

A-4 Thermal Oxidizer (H-4606)

A-44 Off Gas Caustic Scrubber (H-4601)

A-45 Off Gas Caustic Scrubber

Valero Benicia Refinery, Facility No. B2626

S-9 Blowdown System (fuel gas recovery system)

Valero Refining Company - California is submitting this application to the Bay Area Air Quality Management District (BAAQMD) for a Permit to Operate (PTO). This application removes from service an atmospheric pressure relief device (PRD) and associated blowdown drum (D-4614) at Benicia Asphalt Plant (BAP). This project will eliminate the potential of releasing unburned hydrocarbons from the BAP Crude Unit (S-18) to the atmosphere in the event of a unit upset, by re-routing any Crude Unit release through a new blowdown line connected to the Valero Refinery's blowdown system (S-9). The current relief system for S-18 goes to a blowdown drum (D-4614) where flow is limited by a restriction orifice (RO) to the BAP thermal oxidizer H-4606 (A-4). Thus, any excess pressure in the blowdown drum is relieved to the atmosphere through a rupture disk (BAAQMD PRD Unique Number 46243).

The rupture disk (BAAQMD PRD Unique Number 46243) currently installed on the blowdown drum, (D-4614) has had one previous release (April, 2006). In accordance with BAAQMD Regulation 8, Rule 28, the facility shall, within one year of the second event, vent the pressure relief device to a vapor recovery or disposal system with at least 95 percent by weight organic compounds control efficiency, and the control system shall be properly sized per manufacturer's recommendations to handle the material from all devices it is intended to serve in the event of a second atmospheric release event.

With a new blowdown line available from the BAP Crude Unit to the Refinery, S-18 offgas will also be re-routed from the BAP Vacuum Heater (S-19) to the Refinery Blowdown System (fuel gas recovery system) (S-9). The installation will also require a new blowdown drum, compressors, pumps, and associated piping and fugitive components at BAP, and fugitive components at the Refinery. By re-routing BAP S-18 offgas to the Refinery fuel gas scrubbing system, the BAP offgas caustic scrubbers (A-44 and A-45) will also be eliminated, thereby reducing the existence of the safety hazards associated with the scrubbing system.

As a result of the proposed project, the BAP Vacuum Heater (S-19) will no longer be fired with Crude Unit (S-18) offgas, but instead will be fired with cleaner and more reliable 100% natural gas. There will be no change in S-19 maximum fired duty.

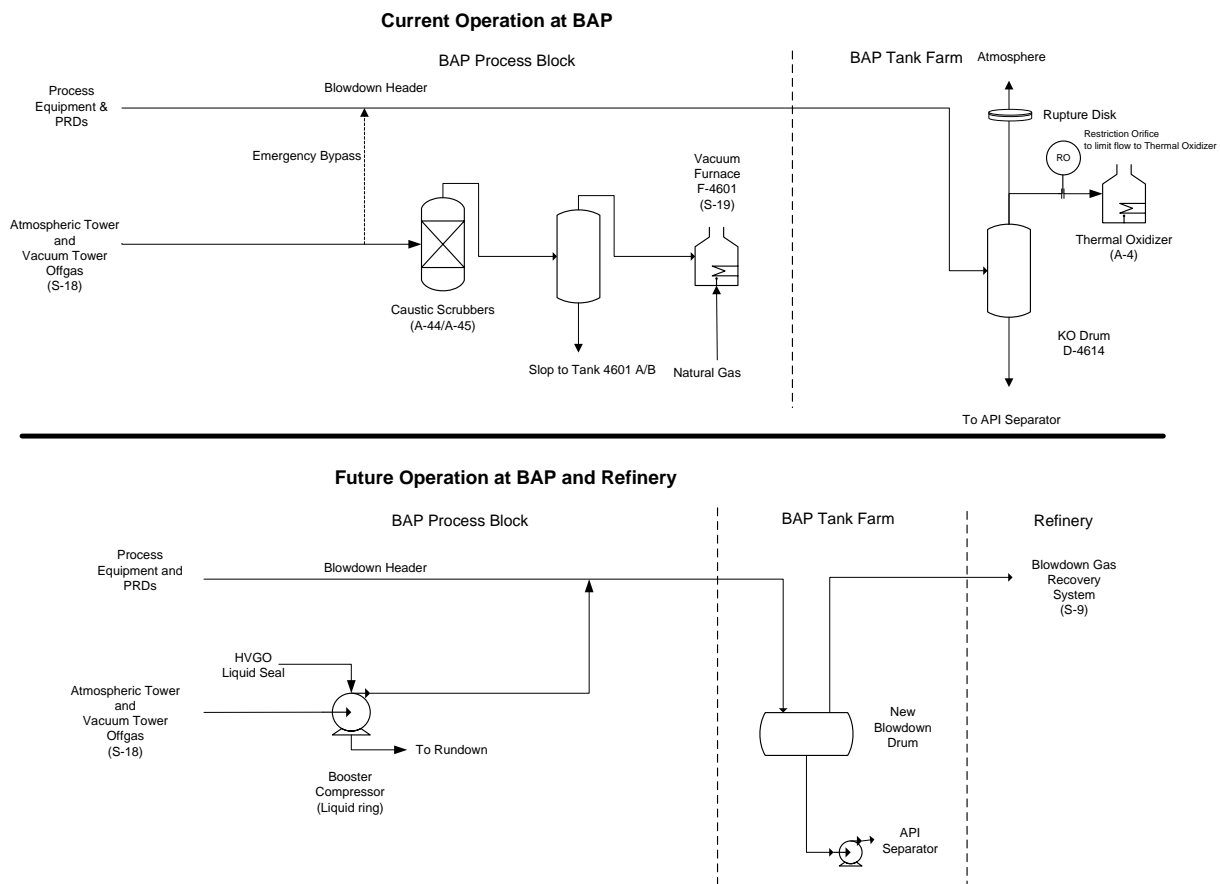

Project Description and impacts on the FMP

The proposed project will route the offgas from S-18 (BAP crude unit) to Refinery Blowdown System (S-9). Under normal operation, BAP offgas will then be recovered by A-13/A-26 Vapor Recovery Compressors, combined with Refinery sour fuel gas, scrubbed in the Refinery amine scrubbing system, and combusted in Refinery heaters, boilers, gas turbines, and cogeneration. The BAP offgas rate of about 0.15 MMSCFD is an insignificant increase in the base vapor load of the S-9 Refinery Blowdown System, which is abated by A-13/A-26 Vapor Recovery Compressors each with a nominal capacity of about 6 MMSCFD for a total 12 MMSCFD capacity under normal circumstances. Under normal operation, the impact of the BAP offgas would be approximately 1% of the recovery capacity which is a de minimis impact.

The Valero Benicia Refinery is subject to BAAQMD Regulation 12 Rule 12 Flares at Petroleum Refineries. The Regulation requires refineries to reduce emissions from flares by minimizing the frequency and magnitude of flaring through preparation and implementation of a comprehensive Flare Minimization Plan (FMP). Valero submitted the annual update of the FMP to the District on July 16, 2008. In accordance with BAAQMD Regulation 12 Rule 12 Section 301, the proposed project is consistent with the FMP. In accordance with BAAQMD Regulation 12 Rule 12 Section 404.2, the proposed project is included in the July 16, 2008 FMP update.

However, BAAQMD 12-12-101 specifically states: *“The purpose of this rule is to reduce emissions from flares at petroleum refineries by minimizing the frequency and magnitude of flaring. Nothing in this rule should be construed to compromise refinery operations and practices with regard to safety.”*

The most important reason for routing BAP Crude Unit (S-18) offgas to the Refinery Blowdown System (S-9) is to proactively comply with BAAQMD Regulation 8, Rule 28. This is a critical safety project to reduce the potential atmospheric hydrocarbon emissions from BAP by abating S-18 PRD releases to an enclosed system (S-9) for vapor recovery and/or combustion in Refinery flare(s) which are designed for emergency releases. The rupture disk (BAAQMD PRD Unique Number 46243) currently installed on the blowdown drum, (D-4614) has had one previous release (April, 2006). In accordance with BAAQMD Regulation 8, Rule 28, [in the event of a second atmospheric release event, the facility shall, within one year of the second event, vent the pressure relief device to a vapor recovery or disposal system with at least 95 percent by weight organic compounds control efficiency, and the control system shall be properly sized per manufacturer’s recommendations to handle the material from all devices it is intended to serve].

Valero is proactively removing the Crude Unit PRD from atmospheric release service prior to a second release event. Furthermore, the removal of the BAP caustic scrubbing system (A-44 and A-45) precludes the vapor from being recovered, scrubbed for H₂S and used at the Asphalt plant. The removal of the caustic system is an additional safety and waste minimization incentive for this project. The emissions and safety concerns associated with an atmospheric release event are far greater than any potential emissions that may occur from the flares during upset conditions. Retaining the caustic scrubbing systems to combust BAP offgas in A-4 loading rack thermal oxidizer would require that the PRD remain as currently installed, thereby precluding the entire project goal of increased safety and reduced emissions through the removal of the rupture disk. Additionally, retaining the caustic scrubbing system at BAP and only using it during refinery upsets is not technically feasible.

In summary, the impact on the fuel gas recovery system is de minimis in contrast with the improved safety and reduction of environmental impacts due to an atmospheric release.

Subpart Ja

The proposed project potentially subjects the refinery flares to the requirements of 40 CFR 60, Subpart Ja – Standards of Performance for Petroleum Refineries. However, EPA has extended the stay on flaring and heater NO_x issues and the finalized requirements have not been fully determined. The determination of applicability to NSPS Subpart Ja can only be conducted after resolution of the regulatory stay. Additionally, previous refinery projects have likely already triggered Subpart Ja requirements for flares, which would become effective after the stay, based on the future effective dates contained in the final rule. This project does not need to include the applicability of Subpart Ja. A separate application for Subpart Ja applicability to the flare will need to be submitted once the rule is finalized and the stay expires.

II. EMISSION CALCULATIONS

The burner replacement at S-19 will continue to comply with the 25ppmv NO_x limit of Condition 1240.I.8 and 50 ppmv limit of Condition 1240.I.5b and CO emissions (1.47 lb/hr) of Condition 1240.5C. Combusting only clean natural gas in the new burners will ensure SO₂, particulate and VOC emissions will not increase.

Fugitive emissions associated with the existing piping of BAP Crude Unit (S-18) offgas to the Vacuum Heater (S-19) via the caustic scrubbers (A-44/A-45) will be removed. New fugitive components associated with the piping of Crude Unit (S-18) offgas to the Refinery Blowdown System (S-9) via booster compressors will be added as a result of the proposed project. Table 1 summarizes the estimated net decrease in VOC emissions associated with fugitive components.

Table 1

Fugitive Emissions Estimate

Component	Proposed Project Count (New)	Existing Count (Demolished)	Proposed Project Count (Net)	Emission Factor (lb/day/component)¹	Emissions (lb/hr)	Emissions (lb/day)
Valves	26	47	(21)	0.00119	-1.04E-03	-2.50E-02
Compressor Seal	2 ²	0	2	0.00150	1.25E-04	3.00E-03
PRV	1 ³	1	(1)	0.00275	-1.15E-04	-2.75E-03
Connectors	73	123	(50)	0.00166	-3.46E-03	-8.30E-02
				Total	-0.0045	-0.11

Notes:

1. Emissions based on site-specific emission factors except for existing PRV which is based on emission factor obtained from 1995 EPA Protocol for Equipment Leak Emission Estimates, Refinery Average.
2. New compressor seals have no emissions due to enclosed seal systems consistent with 40 CFR 60 GGGa.
3. All new PRVs must be controlled per 8-28-301, so have no fugitive emissions and are exempt from 8-18 at 8-18-110.

STATEMENT OF COMPLIANCE

S-19 Vacuum Heater is subject to and continues to comply with Regulation 9 Rule 10- Process Heaters in Petroleum Refineries. S-19 is operating under the District's approved Alternate Control Plan (NOx Box Condition # 21233 and # 19329).

The sources in this application are also subject to and continue to comply with 40 CFR 63 Subpart CC - NESHAPs for Petroleum Refineries

This project is considered to be ministerial under the District's CEQA Regulation 2-1-311 and therefore is not subject to CEQA review. The engineering review for this project requires only the application of standard permit conditions and standard emission factors in accordance with Permit Handbook Chapter 2.1.

This project is also considered to be categorically exempt under the District's CEQA Regulation 2-1-312.2 and 2-1-312.3, and therefore not subject to CEQA review. This permit application is to install air pollution or abatement equipment to bring the Valero Benicia Refinery into compliance with Regulation 8-28-304.2, which required all emissions from the pressure relief device that vents the second Release Event to a vapor recovery or disposal system with at least 95 percent by weight organic compounds control efficiency.

Valero is not located within 1,000 feet of any school. The public notification requirements of Regulation 2-1-412 are not required.

BACT, Offsets, and PSD are not applicable.

CONDITIONS

Condition #1240 For All Sources Updated by Application 19193

Permit Conditions II. 1, 11, 12, and 13; and IV. 1, 2, and 3 were modified or added as part of App. No. 14513.

Pursuant to permit application #17515, permit condition I.8 was modified, conditions I.9 and I.10 were added, and what had been conditions I.9 and I.10 were renumbered as I.11 and I.12, respectively.

Pursuant to permit application #17687 the total asphalt plant wide heat input has been corrected from 42 to 66.17 MMBTU/HR, S13 and S59 were permitted, and S12 was exempted from permitting.

Pursuant to permit application #1261 (May, 2000) the total asphalt plant-wide heat input has been corrected from 76.06 to 86.6 MMBTU/HR, and the allowable heat input for S19 was increased from 22.4 to 33 MMBtu/hr.

Pursuant to permit application #1819 (October, 2000), the crude oil throughput to the crude unit, S18, was raised to 5,292,000 barrels/yr.

Pursuant to permit application #7123 (March, 2003) the total asphalt plant-wide heat input has been corrected from 86.6 to 93.6 MMBTU/HR, and the allowable heat input for S19 was increased from 33 to 40 MMBtu/hr.

Pursuant to permit application # 19193 (February, 2009), process offgas from S18 Crude Unit routed from the S19 Vacuum Heater to the refinery fuel gas recovery system, S9, Facility B2626.

ASPHALT PLANT CONDITIONS S18 Crude Unit, Amended by Application 19193

1. The total throughput of feed oil to S18 Crude Unit shall not exceed 5,292,000 barrels in any consecutive 12-month period.
(cumulative increase, toxics, offsets)
2. The total throughput of feed oil to S18 Crude Unit shall not exceed 18,000 barrels in any calendar day. (cumulative increase, toxics)
3. The owner/operator of S-18 Crude Unit shall vent its emissions to the refinery fuel gas recovery system S-9 at all times.(cumulative increase, toxics)
4. Each day, the permittee shall record, by material name, in a District approved log, the total volume of each and every liquid material throughput to S18 during

the preceding calendar day, in gallon units or barrel units. At the conclusion of each month, the permittee shall total the daily log records and record the sum as the monthly throughput of all liquid materials to S18, in a District approved log. Additionally, the permittee shall record in the District approved log the throughput of all liquid materials to S18 for each rolling 12 consecutive month period. This log shall be retained for at least 5 years from date of entry, shall be kept on site, and shall be made available to the District staff on request. (cumulative increase)

5. The maximum heat input to all asphalt plant combustion units except S68, Emergency Diesel-Powered Firewater Pump, shall not exceed a total of 93.6 MM BTU/Hr. Compliance will be determined from the daily reading of the PG&E natural gas flow meter. These meter readings shall be logged and initialed by the operations coordinator on a daily basis. These readings and the monthly PG&E bills shall be made available to the District upon request. (cumulative increase)

5a. The owner/operator of S-19 shall only use natural gas and the maximum heat input to S19, Vacuum Heater, shall not exceed 40 MMbtu/hr. (cumulative increase)

5b. CO emissions in the exhaust of S19, Vacuum Heater, shall not exceed 50 ppmdv at 3% oxygen over any one-hour period. (cumulative increase, BACT)

5c. CO emissions in the exhaust of S19, Vacuum Heater, shall not exceed 1.47 lb/hr over any one-hour period. (cumulative increase, BACT)

6. Fuel oil and/or diesel fuel shall not be combusted in the asphalt plant's heaters or boilers or other combustion sources except for S68, Emergency Diesel-powered Firewater Pump and S71, Emergency Diesel-powered Air Compressor. (cumulative increase) (modified 8/12/99, 4/24/02, 4/19/06)

7. Mechanical seals will be installed on all new rotary pumps and compressors. Mechanical packing of best available design will be installed in new reciprocating pumps. All compressor seals will be vented to an operating firebox or the vapors will otherwise be eliminated by a method, which is satisfactory to the District. (cumulative increase)

8. Vacuum Heater (S19) shall be equipped with a John Zink LoNOx Burner. Average NOx emissions from S19 shall not exceed 25 ppm corrected to 3% oxygen on a dry basis (one hour averaging period). (cumulative increase, BACT)

9. Deleted 06/02/98.

10. Boilers S20 and S21 and heater S19 shall be equipped with individual continuous recording oxygen analyzers. (2-1-403)

11. Contingent on EPA's approval of 40 CFR 60, Subpart Ja – Standards of Performance for Petroleum Refineries, the owner/operator shall submit a permit application the District for NOx and flaring applicability and revise the Title V permit if necessary. (Regulation 2-1-403)

12. Deleted (vacuum exhaust routed from S19, Vacuum Heater to refinery fuel gas recovery system, S9, Facility B2626)

13. Deleted (vacuum exhaust routed from S19, Vacuum Heater to refinery fuel gas recovery system, S9, Facility B2626)

14. Total asphalt plant emissions shall not exceed the limits listed below:

- | | |
|--|----------------|
| a. Non-Methane Hydrocarbons..... | 42.705 tons/yr |
| b. Sulfur Dioxide, SO ₂ | 28.049 tons/yr |
| c. Nitrogen Oxides, as NO ₂ | 40.047 tons/yr |
- (Cumulative Increase)

15. Asphalt plant wastewater and refinery wastewater shall not be used for dust control at this facility. (Cumulative Increase)

16a. The permit holder shall perform a source test at S19, Vacuum Heater, every 6 months to determine compliance the NO_x limit in part I.8 of this condition, and the CO limit in parts I.5b and I.5c of this condition. The source test shall be performed at the highest duty possible for the prevailing process conditions. All source testing shall be done in accordance with the District's Manual of Procedures. The facility shall receive approval from the District's Source Test Manager for installation of test ports and source testing procedures. The results shall be delivered to the District no later than 60 days from the date of the source test. (Cumulative Increase, BACT)

16b.

17. A/C source test condition, deleted.

18. To assure compliance with part I.14 of Condition 1240, the permit holder shall perform the following monitoring on a semi-annual basis, starting on January 1 of each year.

18a. The permit holder shall estimate emissions of Non-methane hydrocarbons (NMHC) and nitrogen oxides for each quarter.

18b. The permit holder shall estimate fugitive NMHC emissions from valves, flanges, pumps, and compressors using the draft "California Implementation Guidelines for Estimating Mass Emissions of Fugitive Hydrocarbon Leaks at Petroleum Facilities" dated February 1999, or later version.

18c. The permit holder shall estimate tank NMHC emissions from the following tanks using the most recent version of EPA's "Tanks" program or EPA publication AP-42: S3, S5S9, S13, S37, S38, S51-S53, S59-S63, S65, S70.

18d. The permit holder shall estimate NMHC emissions from the following loading racks using EPA publication AP-42: S14, S15, S16, S17, S31, S54.

18e. The permit holder shall estimate NMHC emissions from the following wastewater sources using the most recent version of EPA's "Water" program: S12, S25-S28, S41, S66, S67. The permit holder may use maximum potential to emit in place of measured throughput.

18f. The permit holder shall estimate NMHC emissions from the following combustion sources: S19-S21. The permit holder shall use fuel measurements for each fuel, the F-factor method in EPA Method 19, and the average concentration in the last source test for these estimates.

18g. The permit holder shall estimate NMHC emissions from the following combustion sources: S24, S34, A4, A31. The permit holder shall use the

maximum capacity as an estimate of the fuel usage, and the appropriate emission factor from EPA publication AP-42. The permit holder shall estimate NMHC emissions from S68 and S71. The permit holder shall use the maximum capacity as an estimate of the fuel usage, the actual hours of operation, and the appropriate emission factor from EPA publication AP-42.

18h. The permit holder shall estimate emissions of nitrogen oxides (NO_x) from the following combustion sources: S19-S21. The permit holder shall use fuel measurements for each fuel, the F-factor method in EPA Method 19, and the average concentration in the last source test for these estimates.

18i. The permit holder shall estimate emissions of nitrogen oxides (NO_x) from the following combustion sources: S24, S34, A4, A31. The permit holder shall use the maximum capacity as an estimate of the fuel usage, and the appropriate emission factor from EPA publication AP-42. The permit holder shall estimate NO_x emissions from S68 and S71. The permit holder shall use the maximum capacity as an estimate of the fuel usage, the actual hours of operation, and the appropriate emission factor from EPA publication AP-42.

18j. Within 30 days after the end of each semi-annual period, the permit holder shall calculate the emission estimates required by parts I.18b through 18i for the quarter, summarize the emission estimates for the period, and for the previous period. If the emission estimates exceed the limits in part I.14 of Condition 1240, the permit holder shall report non-compliance with part I.14 of this condition in accordance with Standard Condition I.F of the Title V permit. The emissions estimates shall be kept on-site for a minimum of five years and be made available to District staff upon request. (Cumulative Increase)

19. Within 90 days of issuance of the Title V permit, the Owner/Operator shall install continuous temperature monitoring and recording device for A4, Thermal Oxidizer. The Owner/Operator shall operate A4 Thermal Oxidizer at a minimum temperature of 1400F. (Source Test requirement completed May 20, 2004 and minimum operating temperature added per Application 11815.) (2-6-503)

19a. The temperature limit in part I.19 shall not apply during an "Allowable Temperature Excursion", provided that the temperature controller setpoint complies with the temperature limit. An Allowable Temperature Excursion is one of the following:

- a. A temperature excursion not exceeding 20 degrees F; or
- b. A temperature excursion for a period or periods which when combined are less than or equal to 15 minutes in any hour; or
- c. A temperature excursion for a period or periods which when combined are more than 15 minutes in any hour, provided that all three of the following criteria are met.
 - i. the excursion does not exceed 50 degrees F;
 - ii. the duration of the excursion does not exceed 24 hours; and
 - iii. the total number of such excursions does not exceed 12 per calendar year (or any consecutive 12 month period).

Two or more excursions greater than 15 minutes in duration occurring during the same 24-hour period shall be counted as one excursion toward the 12 excursion limit. (basis: Regulation 2-1-403)

19b. For each Allowable Temperature Excursion that exceeds 20 degrees F. and 15 minutes in duration, the Permit Holder shall keep sufficient records to demonstrate that they meet the qualifying criteria described above. Records shall be retained for a minimum of five years from the date of entry, and shall be made available to the District upon request. Records shall include at least the following information:

- a. Temperature controller setpoint;
 - b. Starting date and time, and duration of each Allowable Temperature Excursion;
 - c. Measured temperature during each Allowable Temperature Excursion;
 - d. Number of Allowable Temperature Excursions per month, and total number for the current calendar year; and
 - e. All strip charts or other temperature records.
- (basis: Regulation 2-1-403)

19c. For the purposes of parts I.19a and I.19b, a temperature excursion refers only to temperatures below the limit. (basis: Regulation 2-1-403)

20. Deleted Application 9297

II. TANKAGE AND LOADING RACK CONDITIONS:

1. Deleted in Revision 2. Ownership of S2 transferred to Facility B5574 by Application No. 7980/8915.
2. Deleted 5/01. Redundant with condition 1240 II.26.
3. Deleted 07/20/99. Redundant with condition 1240 II.27.
4. Deleted 07/20/99. Redundant with condition 1240 II.54.
5. Deleted 07/20/99. Redundant with condition 1240 II.60.
6. Deleted (basis: requirement no longer applicable since exhaust from S18 Crude Unit routed from the S19, Vacuum Heater to the refinery fuel gas recovery system, S9, Facility B2626)
7. Deleted 07/20/99. Redundant with condition 1240 II.51.
8. Asphalt loading at S17 shall be immediately terminated if the blowdown system is venting to the thermal oxidizer (A4). (Cumulative Increase)
9. Deleted 08/12/99.

RECOMMENDATION

Issue a conditional change to the Permit to Operate to Valero Refining Company for the following equipment:

Valero Benicia Asphalt Plant (BAP), Facility No. A0901
S18 – Crude Unit
S19 – Vacuum Heater,
H-4606 A4 – Thermal Oxidizer,

Permit Evaluation and Statement of Basis: Site A0901, Valero Benicia Asphalt Plant, 3001 Park Road, Benicia, CA 94510

Valero Benicia Refinery, Facility No. B2626
S9 – Blowdown System (fuel gas recovery system)

Archived the following equipment:

Valero Benicia Asphalt Plant (BAP), Facility No. A0901

A44 – Off Gas Caustic Scrubber, H-4601

A45 – Off Gas Caustic Scrubber

Thu H. Bui
Senior Air Quality Engineer
Engineering Division

Date: _____

THB:C:\Valero\19193

**EVALUATION REPORT
VALERO BENICIA ASPHALT PLANT**

Application #19384 - Plant #A0901

**3001 Park Road
Benicia, CA 94510**

I. BACKGROUND

Valero has applied for a change of conditions to the Permit to Operate for the following equipment:

Abatement Devices:

A-31 H-4607 Thermal Oxidizer, 3.5 MMBtu/hr

S-24 H-4603 Hot Oil Heater, 9.0 MMBtu/hr

Abated Sources:

S-3 TK-1C Gas Oil Tank

S-5 TK-2A Asphalt Tank

S-6 TK-2B Asphalt Tank

S-7 TK-3 Asphalt tank

S-8 TK-4 Asphalt Tank

S-13 TK-8 Kerosene Tank

S-25 TK-11A WWTP Effluent Water Tank (to be archived)

S-31 Asphalt/Gas Oil Rail Car Loading Rack

S-37 TK-54 Rubberized Asphalt Sales Tank

S-38 TK-55 Rubberized Asphalt Sales Tank

S-41 Wemco Hydrocleaner

S-51 TK-506 Asphalt Sales Tank

S-52 TK-507 Asphalt Sales Tank

S-53 TK-508 Asphalt Sales Tank

S-54 TK-Asphalt Truck Loading Rack

S-59 TK-5 Gas Oil Tank

S-60 TK-505 Asphalt Tank

- S-61 TK-30A Asphalt Tank**
- S-62 TK-30B Asphalt Tank**
- S-63 TK-31 Kero/LVGO/HVGO/Asphalt Tank**
- S-65 TK-32 Asphalt Tank**
- S-66 WWTP Oil-Water Separator**
- S-70 TK-500 Asphalt Additive Mixing Tank**

SUMMARY

A-31 (H-4607) thermal oxidizer is the primary abatement device for the Benicia Asphalt Plant (BAP), and controls organic emissions from 30 sources connected to a vapor recovery system. In addition, S-24 (H-4603) hot oil heater maintains the temperature of the asphalt tanks by circulating hot oil through the tanks, but it can also be used to abate emissions from the 30 sources when A-31 is shut down or unavailable. The 23 sources listed above are required by permit conditions to be controlled by A-31 or S-24. Seven additional sources (not listed) are abated by A-31 or S-24 without permit requirements, either as an option to comply with Part 61 Subpart FF (5 in the WWTP) or as a voluntary operation (2 exempt tanks).

All 31 sources at the BAP must maintain a required minimum combustion zone temperature and be abated by A-31 and S-24 at all times Condition # 1240 Part II. These conditions are problematic whenever a power failure occurs at the BAP, because the abatement devices shut down and combustion zone temperatures drop below minimum when most of the sources are still in service (such as storing organic material), resulting in potential violations of these permit conditions. Between August 2005 and June 2008, Valero received 15 notices of violation for various problems, but most of them were power failures due to PG&E Bahia Substation power trips. The BAP's power outages were caused by PG&E unreliable supply of power such as the power blip, power line switch fault and interruption of the circuit breaker by a squirrel, ect... at the substation.

The permit conditions assumed that emissions occurred whenever A-31 or S-24 shut down while abating emissions and combustion zone temperature dropped below minimum. Based on a review of the operation of the BAP's storage tanks, emissions do not occur when A-31 or S-24 shuts down and combustion zone temperature drops below minimum. Instead, emissions remain contained in the extra vapor space above the tanks, because the vapor recovery blowers, which convey emissions from the sources to the abatement device, shut down at the same time, preventing vapors from leaking into A-31 or S-24. Furthermore, vapors are not released through pressure/vacuum (P/V) valves on the closed vent system when the blowers are shut down, as long as the closed vent system does not over-pressure. Accordingly, there is no increase in emissions from existing levels with this application.

The revisions to the permit conditions resolve operating situations when A-31 and S-24 are not abating emissions and the vapor recovery blowers are not operating, including, but not limited to, plant-wide power failures, loss of a vapor recovery blower(s), maintenance activities on H-4607, etc. The permit revisions: 1) clarify that the minimum combustion zone temperature is applicable only when emissions are vented to A-31 or S-24; and 2) specify that emissions can be abated by either: A) venting emissions through the vapor recovery system to A-31 or S-24; or B) containing

emissions in the closed vent system, as long as P/V valves in the system are not lifting (new). To determine whether the P/V valve is gas tight or not, the District proposed that leaks of total organic compound to be less than 500 ppmv when the vapor recovery blower is not operating in Condition 1240.II, Part 96.

VAPOR RECOVERY SYSTEM

The majority of sources at the BAP are abated to a vapor recovery system that conveys emissions by vapor recovery blowers to A-31 (H-4607) thermal oxidizer or S-24 (H-4603) hot oil heater. The abated sources include asphalt tanks, gas oil tanks, wastewater equipment, and loading racks. Collectively, these sources generate only a small amount of emissions, because the vapor pressures of the materials are very low. Higher vapor pressure materials, such as crude oil and naphtha, are stored in floating roof tanks and thus not connected to the vapor recovery system.

Figure I below is a simplified flow diagram of the BAP vapor recovery system. A total of 30 sources are vented to the vapor recovery system. The vapor recovery system includes two large vapor collection headers (designated as header #1 and header #2), each connected to a separate blower. Collection header #1 abates 13 sources (7 sources require abatement) and vents to vapor recovery blower B-4608. Collection header #2 abates 16 sources (14 sources require abatement) and vents to vapor recovery blower B-46500. Each collection header can also use common spare blower B-46501 if necessary. A third small collection header for S-31 railcar loading rack only vents to vapor recovery blower B-4603. Each blower pulls a slight vacuum on the vapor recovery system as it conveys emissions to the abatement device. A separate vapor recovery system, which abates emissions only from S-17 asphalt truck loading rack to A-4 (H-4606) loading rack oxidizer, is not part of this permit application. The majority of vent gas flow to the abatement device is air, because the capacities of the blowers are much greater than emissions generated from the sources.

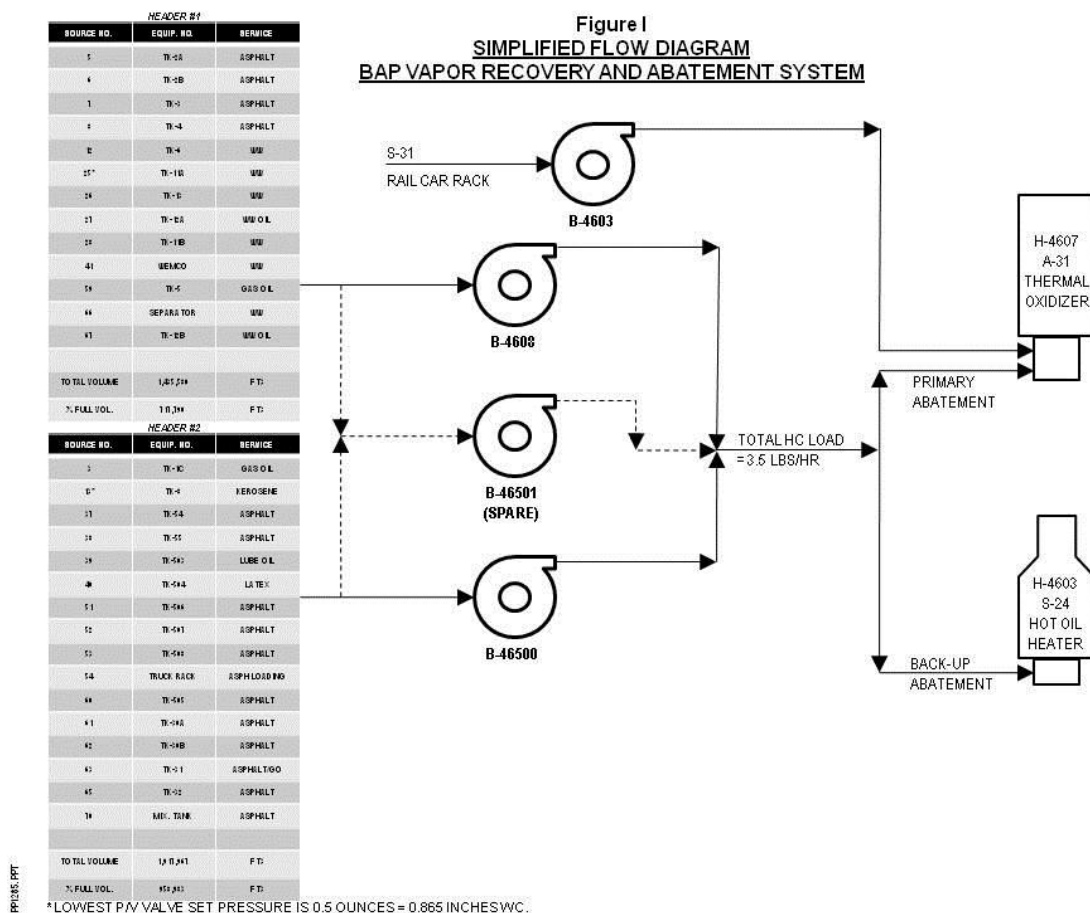

The total volume of equipment connected to both collection headers is substantial. In particular, the total volume of empty equipment connected to header #1 (blower B-4608) and header #2 (B-46500) is about 1.44 and 1.92 million cubic feet, respectively. Most of the equipment operates at about half full, because the equipment is primarily tanks, which routinely fill and empty. Therefore, the estimated total head space in the vapor recovery system with half full equipment is about 1.68 million cubic feet $[=1/2*(1.44+1.92)]$. This large head space has the capacity to accumulate substantial emissions before the system will over-pressure and release emissions to atmosphere through a pressure/vacuum (P/V) valve. The abated sources are equipped with P/V valves, which have (atmospheric) set points ranging from 0.5 to 3.5 ounces (0.87 to 6.0 inches water column, or WC).

When a plant-wide power failure occurs at BAP, all equipment including A-31, S-24, and the vapor recovery blowers shut down at the same time. When the blowers are down, emissions are contained in the closed vent system. During a power failure, the hot oil heaters and electric pumps that circulate hot oil through the heaters and tank coils to keep the asphalt tanks warm also shut down. As the asphalt tanks cool down, both the quantity of emissions generated from the tanks and the temperature of the vapor recovery system decrease, preventing the vapor recovery system from over-pressuring and releasing emissions through P/V valves. With loss of power, the crude unit also shuts down, including the crude unit feed pumps and the rundown streams from the crude unit to the abated tanks. Tank rundown displaces tank vapors into the vapor recovery system via “piston action” (working losses) at a much higher rate than emissions generated by the vapor pressure of the material in the sources (evaporative losses). With no rundown to tankage,

there are no working losses, just evaporative losses. Finally during a power failure, the railcar and truck loading racks also shut down and do not generate loading emissions.

After power is restored to the BAP, A-31 Thermal Oxidizer (H-4607) is restarted on “fresh air” using B-4603 railcar loading rack blower. After the minimum required combustion zone temperature is re-established in A-31 on “fresh-air”, the two blowers (B-4608 and B-46500) on the vapor recovery system are restarted to begin conveying vapors to A-31.

A-31 (H-4607) may also shut down automatically from inadvertent loss of blowers, with power still available at BAP. In addition, A-31 and the blowers may be shut down manually to conduct maintenance on A-31, the natural gas line to BAP, the vapor recovery system, etc. Before A-31 is shut down manually, the vapor recovery blowers are first shut down.

A-31 (H-4607) can operate if at least one blower is operating. A single blower operation may occur, for example, if one blower inadvertently shuts down or is manually shut down for maintenance, while the other blower(s) continues to operate.

II. EMISSION CALCULATIONS

This application will not result in an emissions increase.

In February 2004, a source test was conducted on A-31 and S-24 under normal plant operations to demonstrate compliance with the minimum destruction efficiency of 98.5%, set forth in Condition 1240.II.58b of the BAP Title V permit. The source test measured hydrocarbon emissions of about 3.5 lbs/hour at the inlet to A-31. The low emission rate is reasonable, considering the low vapor pressures of the abated asphalt and gas oil tanks and wastewater equipment. See the attached test result.

Emissions of about 3.5 lbs/hour are equivalent to about 85 SCFH or about 134 ACFH at 370 F (typical temperature of asphalt tanks), based on a molecular weight of 16.0 lbs/mole for methane. This emission rate is conservatively high for two reasons. First, emissions of about 3.5 lbs/hour were measured when the vapor recovery blowers were operating, which induces vapor head space and promotes generation of emissions compared to a static head space. Second, the assumed head space temperature of 370 F is conservatively high, because only 16 of the 30 abated sources are asphalt tanks which operate at 370 F, while the remaining 14 of the 30 abated sources (gas oil tanks and wastewater equipment) are operating at near ambient conditions.

Based on a normal emission rate of about 3.5 lbs/hour or 134 ACFH with all blowers shut down, it is estimated to take about 27 hours to increase the pressure of the approximate 1.68 million cubic feet of head space in the vapor recovery system from atmospheric pressure to the lowest P/V valve set pressure of 0.5 ounces (0.87 inches WC). P/V valves with set pressures of 0.5 ounces are located on S-25 (TK-11A, effluent water tank) in collection header #1 (B-4608), and S-13 (TK-8, kerosene tank) in collection header #2 (B-46500). The estimated time of 27 hours to increase the pressure of the vapor recovery system by 0.5 ounces (0.87 inches WC) is calculated as follows:

$$\text{Time}_i = \frac{1}{2} * (1.44 + 1.92) * 10^6 \text{ ft}^3 / (134 \text{ ft}^3/\text{hour}) / 14.7 \text{ psia} * (14.7 \text{ psia} / 235.1 \text{ oz}) * 0.5 \text{ oz} = 27 \text{ hours.}$$

The estimated time to increase the pressure of the vapor recovery system by 0.5 ounces is conservatively low when all the blowers are down. The asphalt tanks will begin to cool down

with loss of the hot oil heaters and hot oil circulation pumps, reducing both the quantity of emissions generated from these sources and the overall temperature of the vapor recovery system.

Valero has submitted a separate permit application to exempt S-25 (TK-11A effluent water tank), which currently has the lowest P/V valve set pressure (0.5 ounces) of the 13 sources in collection header #1 (B-4608). When S-25 is disconnected from vapor recovery, the source with the next lowest P/V valve set pressure in collection header #1 is S-5 (TK-4602A asphalt tank), which has a P/V set pressure of 0.64 ounces (1.1 inches WC). With a higher P/V valve set pressure in collection header #1, the estimated time to over-pressure the header will correspondingly increase.

On February 4, 2009, the block valve on the main natural gas line to BAP was replaced. This required a complete shutdown of all combustion devices at BAP, including A-31, which also required all vapor recovery blowers to be shut down. The valve replacement took about 6 hours to complete the work. Per Valero's agreement with Enforcement, pressure measurements were taken on the closed vent system after the first 4 hours of shutdown. Manometer readings indicated system pressure was still in a vacuum after 4 hours, with readings of (0.2) inches WC vacuum at WWT, (0.3) inches WC vacuum at product tankage, and (0.1) inches WC vacuum at the crude tank area.

Based on the estimated time, the set P/V valve pressure and the latest manometer readings above, the District feels confident to impose Condition 1240.II, Part 93 and 94 requiring Valero to monitor the pressure at each of the representative location of the three headers every 8 hours to make sure the monometer reading is less then 0.5 ounces (0.87 inches of W.C) when the blower is not operating. If the pressure is approaching 0.5 ounces, then Valero must restart A-31 and/or S-24 immediately, so that A-31 and/or S-24 can reach their appropriate operating temperatures before the blower can be turned on.

III. PLANT CUMULATIVE INCREASE SINCE 4/5/1991

There are no net changes to the plant cumulative emissions, because there is emission increase from existing levels with this application.

IV. TOXIC SCREENING ANALYSIS

This application will not result in an increase in toxic air contaminant emissions from existing levels. Therefore, a Toxic RSA is not required per Regulation 2-5.

V. BEST AVAILABLE CONTROL TECHNOLOGY

This application will not result in any emission increase from existing levels. Therefore, BACT is not triggered per Regulation 2-2-301.

VI. OFFSETS

This application does not result in emission increases. Therefore, emission offsets are not needed per Regulation 2-2-302.

VII. STATEMENT OF COMPLIANCE

The tanks at the asphalt plant will continue to be exempt from Regulation 8-5-117 for storing low vapor pressure materials that are less than or equal 0.5 psia.

The oil water separator and wastewater tanks are subject to and compliance with Regulation 8-8 Wastewater Collection and Separation Systems and Regulation 8 Rule 18 Equipment Leaks.

This application is considered to be ministerial under the District's CEQA Regulation 2-1-311 and therefore is not subject to CEQA review. The engineering review for this project requires only the application of standard permit conditions and standard emission factors in accordance with Permit Handbook Chapter 3.3

This project is over 1,000 ft from the nearest public school and is therefore not subject to the public notification requirements of Regulation 2-1-412.

BACT, offsets, and PSD are not triggered.

VIII. CONDITIONS

Listed below are 23 sources in the BAP permits that require abatement by A-31 or S-24 at all times when the equipment is in service or loading organic material, including corresponding permit conditions and vapor collection headers and blowers. For completeness, seven additional sources at the bottom of the list are abated by A-31 or S-24 without permit requirements, either as an option to comply with Part 61 Subpart FF (5 in the WWTP) or as a voluntary operation (2 exempt tanks).

Valero has submitted separate permit Application # 19631 to remove Part 61 Subpart FF control requirements from all BAP wastewater sources, and to archive S-25 (TK-11A effluent water tank). Valero complies with 61.342(e) [6 BQ] option for compliance with Part 61 Subpart FF at its Benicia wastewater facilities and considers all benzene-containing wastes generated at the BAP wastewater facilities to be uncontrolled aqueous waste subject to 61.342(e)(2). Therefore, none of the BAP wastewater sources that handle benzene-containing wastes are subject to the control standards in Part 61 Subpart FF, and all wastewater sources will be disconnected from the vapor recovery system.

Source	Description	Subject to Condition #	Header (Blower)
Abatement Devices H-4607 and H-4603			
A-31	H-4607 Rail Road Thermal Oxidizer	1240.II.58b	
S-24	H-4603 Hot Oil Heater	1240.II.58b	
Sources Requiring Abatement by H-4607 and H-4603			
3	TK-1C Gas Oil Tank	1240.II.43	#2 (B-46500)
5	TK-2A Asphalt Tank	1240.II.55	#1 (B-4608)
6	TK-2B Asphalt Tank	1240.II.55	#1 (B-4608)
7	TK-3 Asphalt Tank	1240.II.55	#1 (B-4608)
8	TK-4 Asphalt Tank	1240.II.55	#1 (B-4608)
13	TK-8 Kerosene Tank	1240.II.32a	#2 (B-46500)
25	TK-11A Effluent Water Tank (to be exempted/disconnected from header #1)	1240.II.10	#1 (B-4608)
31	Asphalt/Gas Oil Rail Car Loading Rack	1240.II.66	(B-4603)
37	TK-54 Rubberized Asphalt Sales Tank	1240.II.55	#2 (B-46500)

Source	Description	Subject to Condition #	Header (Blower)
38	TK-55 Rubberized Asphalt Sales Tank	1240.II.55	#2 (B-46500)
41	WW Wemco Hydrocleaner	1240.II.91a	#1 (B-4608)
51	TK-506 Asphalt Sales Tank	1240.II.56	#2 (B-46500)
52	TK-507 Asphalt Sales Tank	1240.II.56	#2 (B-46500)
53	TK-508 Asphalt Sales Tank	1240.II.56	#2 (B-46500)
54	Asphalt Truck Loading Rack	1240.II.67	#2 (B-46500)
59	TK-5 Gas Oil Tank	1240.II.32b	#1 (B-4608)
60	TK-505 Asphalt Tank	1240.II.56	#2 (B-46500)
61	TK-30A Asphalt Tank	1240.II.57	#2 (B-46500)
62	TK-30B Asphalt Tank	1240.II.57	#2 (B-46500)
63	TK-31 KERO/LVGO/HVGO/Asphalt Tank	1240.II.32c	#2 (B-46500)
65	TK-32 Asphalt Tank	1240.II.56	#2 (B-46500)
66	WW Oil-Water Separator	1240.II.85	#1 (B-4608)
70	TK-500 Asphalt Additive Mixing Tank	1240.II.55, 20278 Part 3	#2 (B-46500)

Sources Connected to, but Not Requiring Abatement by H-4607 and H-4603

12	TK-6 Wastewater Tank	N/A	#1 (B-4608)
26	TK-13 Wastewater Oil Tank	N/A	#1 (B-4608)
27	TK-12A WW Recovered Oil Tank	N/A	#1 (B-4608)
28	TK-11B WW Effluent Water Feed Tank	N/A	#1 (B-4608)
39	TK-503 Lube Oil Tank	N/A	#2 (B-46500)
40	TK-504 Latex Storage Tank	N/A	#2 (B-46500)
67	TK-12B WW Recovered Oil Tank	N/A	#1 (B-4608)

Revisions to Condition 1240.II.58b for abatement device operation clarify that the minimum the combustion zone temperatures required for A-31 and S-24 apply only when emissions are actually vented to the abatement device.

Revisions to permit conditions for each source requiring abatement, as shown in the above table, now include two options to control emissions: 1) vent emissions to A-31 Thermal Oxidizer when the vapor recovery blower is operating; or 2) contain emissions in the closed vent system without lifting a P/V valve on the system when the vapor recovery blower is not operating (new); or 3) vent emissions to S-24 Hot Oil Heater when the vapor recovery blower is operating. Consistent with these permit changes, the description of each abated source has also been updated to reflect three options for controlling emissions.

To ensure emissions are contained in a vapor recovery collection header when the vapor recovery blower is shut down, new conditions 1240.II.93 and 1240.II.94 have been added which require that the pressure of the collection header not to exceed 0.5 ounces and be monitored at least once every eight (8) hours until A-31 or S-24 is turned on and the vapor blower is re-started. Monitoring of vapor recovery collection header pressures are the most viable approach for assuring compliance. Several other alternatives were evaluated to assure emissions did not occur when the blowers were shut down, but these options were eliminated. Specifically, installation of a flow meter on the inlet line to A-31 was considered impractical due to detection limitations from the very low flow of emissions when the blowers are shut down. Installation of a carbon adsorption system was also considered infeasible due to safety concerns with the high oxygen content of the vent gas.

New permit condition 1240.II, Part 95 and 96 require recordkeeping of the pressure at each of the headers and the manometer of the P/V valve should not exceed 500 ppmv of total organic leaks.

Permit Condition 1240.II, Parts 32b, 32c, 43, 55, 56, 57, 69, 70, 85 are combined into Part 32, which required A-31 and S-24 must have an overall collection and destruction efficiency of at least 98.5%.

Permit conditions 1240.II.58c and 1240.II.58d, which specify an “allowable temperature excursion” for A-31, were incorporated into the BAP permits in February, 2008. Two new conditions have been added to clarify that an allowable temperature excursion only occurs when: 1) the combustion zone temperature is below the limit (part 1240.II.58e); and 2) a blower in organic vapor service is vented to S-24 (part 1240.II.58f).

Condition #1240, parts 44, 53, and 86, which required the vapor recovery system to be operated under a negative pressure and also monitored for fugitive emissions, have been deleted. The vapor recovery system is designed to operate under negative pressure to ensure that emissions from the equipment are conveyed away from the equipment to an abatement device by a vapor recovery blower. These conditions stated that equipment must be operated as designed were considered redundant and did not strengthen the permit. Furthermore, these conditions, requiring the vapor recovery system to be monitored for fugitive emissions while operating under a vacuum, were inconsistent with Regulation 8-18-116, which specifically exempts equipment in vacuum service from monitoring for fugitive emissions.

Condition #1240.II, Parts 32d, 44, 53, and 86 also included a fugitive emission standard of 100 ppmv, which applied to every type of fugitive component in the vapor recovery system. These conditions are deleted because they are redundant with Regulation 8-18.

Condition #1240.II, Parts 66 and 67 are deleted because they are redundant with Part 64b for requirement of abating S-31 and S-54 at all times by A-31 and S-24.

Permit condition #1240 for the Valero Benicia Asphalt Plant, amended by Application # 19384, Plant #A0901.

For All Sources

Permit Conditions II. 1, 11, 12, and 13; and IV. 1, 2, and 3 were modified or added as part of App. No. 14513.

Pursuant to permit application #17515, permit condition I.8 was modified, conditions I.9 and I.10 were added, and what had been conditions I.9 and I.10 were renumbered as I.11 and I.12, respectively.

Pursuant to permit application #17687 the total asphalt plant wide heat input has been corrected from 42 to 66.17 MMBTU/HR, S13 and S59 were permitted, and S12 was exempted from permitting.

Pursuant to permit application #1261 (May, 2000) the total asphalt plant-wide heat input has been corrected from 76.06 to 86.6 MMBTU/HR, and the allowable heat input for S19 was increased from 22.4 to 33 MMbtu/hr.

Pursuant to permit application #1819 (October, 2000), the crude oil throughput to the crude unit, S18, was raised to 5,292,000 barrels/yr.

Pursuant to permit application #7123 (March, 2003) the total asphalt plant-wide heat input has been corrected from 86.6 to 93.6 MMBTU/HR, and the allowable heat input for S19 was increased from 33 to 40 MMBtu/hr.

Pursuant to permit application #19384 (February, 2009), All sources that are abated by A-31 or S-24 can now also be contained in the closed vent system when the blower is not operating until the pressure of the system reaches 0.5 ounces (0.87 inches of water column). The P/V valves on all sources abated by A-31 or S-24 shall not exceed 500 ppmv of total organic compounds while the blower is not operating.

I. ASPHALT PLANT CONDITIONS

S18 Crude Unit with Vacuum Distillation Column vented to and abated by S19 Vacuum H-1

1. The total throughput of feed oil to S18 Crude Unit shall not exceed 5,292,000 barrels in any consecutive 12-month period.
(cumulative increase, toxics, offsets)
2. The total throughput of feed oil to S18 Crude Unit shall not exceed 18,000 barrels in any calendar day. (cumulative increase, toxics)
3. At all times, the vacuum exhaust from the vacuum distillation column at S18 Crude Unit shall be vented to and abated by S19 Vacuum Heater with a destruction efficiency for VOC of at least 98.5%, by weight, as measured across S19. (cumulative increase, toxics)
4. Each day, the permittee shall record, by material name, in a District approved log, the total volume of each and every liquid material throughput to S18 during the preceding calendar day, in gallon units or barrel units. At the conclusion of each month, the permittee shall total the daily log records and record the sum as the monthly throughput of all liquid materials to S18, in a District approved log. Additionally, the permittee shall record in the District approved log the throughput of all liquid materials to S18 for each rolling 12 consecutive month period. This log shall be retained for at least 5 years from date of entry, shall be kept on site, and shall be made available to the District staff on request.
(cumulative increase)
5. The maximum heat input to all asphalt plant combustion units except S68, Emergency Diesel-Powered Firewater Pump, shall not exceed a total of 93.6 MM BTU/Hr. Compliance will be determined from the daily reading of the PG&E natural gas flow meter and the asphalt plant refinery fuel gas meter. These meter readings shall be logged and initialed by the operations coordinator on a daily basis. These readings and the monthly PG&E bills shall be made available to the District upon request. Only refinery fuel gas that is produced at the asphalt plant may be burned at the facility. (cumulative increase)

- 5a. The maximum heat input to S19, Vacuum Heater, shall not exceed 40 MMbtu/hr. (cumulative increase)
- 5b. CO emissions in the exhaust of S19, Vacuum Heater, shall not exceed 50 ppmdv at 3% oxygen over any one-hour period. (cumulative increase, BACT)
- 5c. CO emissions in the exhaust of S19, Vacuum Heater, shall not exceed 1.47 lb/hr over any one-hour period. (cumulative increase, BACT)
6. Fuel oil and/or diesel fuel shall not be combusted in the asphalt plant's heaters or boilers or other combustion sources except for S68, Emergency Diesel-powered Firewater Pump and S71, Emergency Diesel-powered Air Compressor. (cumulative increase) (modified 8/12/99, 4/24/02, 4/19/06)
7. Mechanical seals will be installed on all new rotary pumps and compressors. Mechanical packing of best available design will be installed in new reciprocating pumps. All compressor seals will be vented to an operating firebox or the vapors will otherwise be eliminated by a method, which is satisfactory to the District. (cumulative increase)
8. Vacuum Heater (S19) shall be equipped with a John Zink LoNOx Burner. Average NOx emissions from S19 shall not exceed 25 ppm corrected to 3% oxygen on a dry basis (one hour averaging period). (cumulative increase, BACT)
9. Deleted 06/02/98.
10. Boilers S20 and S21 and heater S19 shall be equipped with individual continuous recording oxygen analyzers. (2-1-403)
11. The H2S content in the asphalt plant's refinery process gas prior to mixing with another gaseous fluid shall not exceed the H2S concentration limitation specified in NSPS 40 CFR 60 Subpart J. (NSPS) (Compliance with this condition will not necessarily ensure compliance with part I.12 of this condition.)
12. The H2S content in the asphalt plant's refinery process gas prior to mixing with another gaseous fluid shall not exceed 10 ppmv, dry, averaged over any consecutive 24-hour period. (BACT)
13. The permittee shall operate District approved H2S monitoring and recording instruments which, as set forth in 40 CFR 60 Subpart J, measure and record the content of H2S in the asphalt plant's refinery process gas prior to mixing with another gaseous fluid and which allow the District to determine compliance of the process gas H2S content with both the applicable standard in 40 CFR 60 Subpart J and parts I.11, and I.12 of this condition. These records shall be retained in a District approved log, retained for at least 5 years from date of record, shall be kept on site, and shall be made available to the District staff upon request. (NSPS, BACT)
14. Total asphalt plant emissions shall not exceed the limits listed below:
- | | |
|----------------------------------|----------------|
| a. Non-Methane Hydrocarbons..... | 42.705 tons/yr |
| b. Sulfur Dioxide, SO2..... | 28.049 tons/yr |

c. Nitrogen Oxides, as NO₂..... 40.047 tons/yr
(Cumulative Increase)

15. Asphalt plant wastewater and refinery wastewater shall not be used for dust control at this facility. (Cumulative Increase)

16a. The permit holder shall perform a source test at S19, Vacuum Heater, every 6 months to determine compliance the NO_x limit in part I.8 of this condition, and the CO limit in parts I.5b and I.5c of this condition. The source test shall be performed at the highest duty possible for the prevailing process conditions. All source testing shall be done in accordance with the District's Manual of Procedures. The facility shall receive approval from the District's Source Test Manager for installation of test ports and source testing procedures. The results shall be delivered to the District no later than 45 days from the date of the source test. (Cumulative Increase, BACT)

16b. The permit holder shall perform a source test at S19, Vacuum Heater, every 24 months to determine compliance with the requirement for 98.5% POC destruction efficiency requirement in part I.3. The source test shall be performed at a minimum of 85% of the maximum capacity of 40 MMbtu/hr (34 to 40 MMbtu/hr). All source testing shall be done in accordance with the District's Manual of Procedures. The facility shall receive approval from the District's Source Test Manager for installation of test ports and source testing procedures. The results shall be delivered to the District no later than 45 days from the date of the source test. (Cumulative Increase, Toxics)

17. A/C source test condition, deleted.

18. To assure compliance with part I.14 of Condition 1240, the permit holder shall perform the following monitoring on a semi-annual basis, starting on January 1 of each year.

18a. The permit holder shall estimate emissions of Non-methane hydrocarbons (NMHC) and nitrogen oxides for each quarter.

18b. The permit holder shall estimate fugitive NMHC emissions from valves, flanges, pumps, and compressors using the draft "California Implementation Guidelines for Estimating Mass Emissions of Fugitive Hydrocarbon Leaks at Petroleum Facilities" dated February 1999, or later version.

18c. The permit holder shall estimate tank NMHC emissions from the following tanks using the most recent version of EPA's "Tanks" program or EPA publication AP-42: S3, S5S9, S13, S37, S38, S51-S53, S59-S63, S65, S70.

18d. The permit holder shall estimate NMHC emissions from the following loading racks using EPA publication AP-42: S14, S15, S16, S17, S31, S54.

18e. The permit holder shall estimate NMHC emissions from the following wastewater sources using the most recent version of EPA's "Water" program: S12, S25-S28, S41, S66, S67. The permit holder may use maximum potential to emit in place of measured throughput.

18f. The permit holder shall estimate NMHC emissions from the following combustion sources: S19-S21. The permit holder shall use fuel measurements for each fuel, the F-factor method in EPA Method 19, and the average concentration in the last source test for these estimates.

18g. The permit holder shall estimate NMHC emissions from the following combustion sources: S24, S34, A4, A31. The permit holder shall use the maximum capacity as an estimate of the fuel usage, and the appropriate emission factor from EPA publication AP-42. The permit holder shall estimate NMHC emissions from S68 and S71. The permit holder shall use the maximum capacity as an estimate of the fuel usage, the actual hours of operation, and the appropriate emission factor from EPA publication AP-42.

18h. The permit holder shall estimate emissions of nitrogen oxides (NO_x) from the following combustion sources: S19-S21. The permit holder shall use fuel measurements for each fuel, the F-factor method in EPA Method 19, and the average concentration in the last source test for these estimates.

18i. The permit holder shall estimate emissions of nitrogen oxides (NO_x) from the following combustion sources: S24, S34, A4, A31. The permit holder shall use the maximum capacity as an estimate of the fuel usage, and the appropriate emission factor from EPA publication AP-42. The permit holder shall estimate NO_x emissions from S68 and S71. The permit holder shall use the maximum capacity as an estimate of the fuel usage, the actual hours of operation, and the appropriate emission factor from EPA publication AP-42.

18j. Within 30 days after the end of each semi-annual period, the permit holder shall calculate the emission estimates required by parts I.18b through 18i for the quarter, summarize the emission estimates for the period, and for the previous period. If the emission estimates exceed the limits in part I.14 of Condition 1240, the permit holder shall report non-compliance with part I.14 of this condition in accordance with Standard Condition I.F of the Title V permit. The emissions estimates shall be kept on-site for a minimum of five years and be made available to District staff upon request. (Cumulative Increase)

19. Within 90 days of issuance of the Title V permit, the Owner/Operator shall install continuous temperature monitoring and recording device for A4, Thermal Oxidizer. The Owner/Operator shall operate A4 Thermal Oxidizer at a minimum temperature of 1400F. (Source Test requirement completed May 20, 2004 and minimum operating temperature added per Application 11815.) (2-6-503)

19a. The temperature limit in part I.19 shall not apply during an "Allowable Temperature Excursion", provided that the temperature controller setpoint complies with the temperature limit. An Allowable Temperature Excursion is one of the following:

- a. A temperature excursion not exceeding 20 degrees F; or
- b. A temperature excursion for a period or periods which when combined are less than or equal to 15 minutes in any hour; or
- c. A temperature excursion for a period or periods which when combined are more than 15 minutes in any hour, provided that all three of the following criteria are met.
 - i. the excursion does not exceed 50 degrees F;
 - ii. the duration of the excursion does not exceed 24 hours; and
 - iii. the total number of such excursions does not exceed 12 per calendar year (or any consecutive 12 month period).

Two or more excursions greater than 15 minutes in duration occurring during the same 24-hour period shall be counted as one excursion toward the 12 excursion limit. (basis: Regulation 2-1-403)

19b. For each Allowable Temperature Excursion that exceeds 20 degrees F. and 15 minutes in duration, the Permit Holder shall keep sufficient records to demonstrate that they meet the qualifying criteria described above. Records shall be retained for a minimum of five years from the date of entry, and shall be made available to the District upon request. Records shall include at least the following information:

- a. Temperature controller setpoint;
 - b. Starting date and time, and duration of each Allowable Temperature Excursion;
 - c. Measured temperature during each Allowable Temperature Excursion;
 - d. Number of Allowable Temperature Excursions per month, and total number for the current calendar year; and
 - e. All strip charts or other temperature records.
- (basis: Regulation 2-1-403)

19c. For the purposes of parts I.19a and I.19b, a temperature excursion refers only to temperatures below the limit. (basis: Regulation 2-1-403)

20. Deleted Application 9297

II. TANKAGE AND LOADING RACK CONDITIONS:

1. Deleted in Revision 2. Ownership of S2 transferred to Facility B5574 by Application No. 7980/8915.
2. Deleted 5/01. Redundant with condition 1240 II.26.
3. Deleted 07/20/99. Redundant with condition 1240 II.27.
4. Deleted 07/20/99. Redundant with condition 1240 II.54.
5. Deleted 07/20/99. Redundant with condition 1240 II.60.
6. The safety relief system for the crude unit, S18 shall vent to the thermal oxidizer (A4). (Cumulative Increase)
7. Deleted 07/20/99. Redundant with condition 1240 II.51.
8. Asphalt loading at S17 shall be immediately terminated if the blowdown system is venting to the thermal oxidizer (A4). (Cumulative Increase)

9. Deleted 08/12/99.

10. Source S25 emissions shall be vented to A1 or A3, Mist Eliminator F-8 or F-10 and A31, Thermal Oxidizer (H-4607), at all times of S25 operation. If A31 and the vapor recovery blower are inoperative, S25 emissions shall be contained in a District approved closed vent system as specified in Parts 93 and 96.

Alternately, S25 emissions shall be vented to source S24, Hot Oil Heater (H-4603), as a backup until A31 is operating. (cumulative increase) (Added 10/27/93)

S1 Crude Oil Storage Tank 1A, External Floating Roof,
Capacity: 3,419,000 Gallons

S2 Crude Oil Storage Tank, External Floating TK-1B,
Capacity: 3,419,000 Gallons

S4 Crude Oil Storage Tank, External Floating Roof,
TK-10A, Capacity: 1,382,000 Gallons

S23 Crude Oil Storage Tank, External Floating Roof,
TK-10B, Capacity: 1,382,000 Gallons

Conditions 11-24 Deleted in Revision 2. Ownership of S1, S2, S4, and S23 transferred to Facility B5574 by Application No. 7980/8915.

S9 Internal Floating Roof Tank, TK-7; Capacity: 571,200 Gallons, White, Storing: Naphtha equipped with a mechanical shoe primary seal, rim mounted secondary seal, and welded deck

25. Material other than Naphtha may be throughput to or stored in S9, if all of the following are satisfied:

- a. the storage of each material complies with all other conditions applicable to this source
- b. the storage of each material complies with all other applicable regulatory requirements
- c. the permittee keeps District approved records that demonstrate to the District's satisfaction that no toxin listed in Table 2-1-316 is emitted from S9 in an amount in excess of the toxin's respective trigger level set forth in Table 2-1-316. (cumulative increase, toxics)

26. The true vapor pressure of each and all material stored in S9 shall not exceed 11 psia. (cumulative increase, toxics)

27a. S9 shall not be operated unless it is equipped with a District approved internal floating roof with a mechanical shoe primary seal, a rim mounted secondary seal, and a welded deck. (cumulative increase, NSPS)

28. The total throughput of all liquid materials to S9 shall not exceed 24,019,000 gallons (571,880 barrels) in any rolling 12 consecutive month period. (cumulative increase, toxics)

29. On a monthly basis, the permittee shall record in a District approved log the total volume of each and all liquid materials throughput to S9 each month and each rolling 12 consecutive month period, in gallon units or barrel units. This log shall be retained for at least 5 years from date of entry, shall be kept on site, and shall be made available to the District staff on request. (cumulative increase)

S13 Fixed Roof Storage Tank (TK-8); Capacity: 88,000 Gallons, Storing: Kerosene, Light or Heavy Vacuum Gas Oil, and Asphalt abated by (either) A3 or A20 Mist Eliminator F-10 or F-500 and A31 Thermal Oxidizer H-4607. If A31

and the vapor recovery blower are inoperative, S13 emissions shall be contained in a District approved closed vent system as specified in Parts 94 and 96. Alternately, S13 emissions shall be vented to source S24, Hot Oil Heater (H-4603), as a backup until A31 is operating. (cumulative increase)

S59 Fixed Roof Storage Tank (TK-5); Capacity: 1,050,000 Gallons, Storing: Kerosene, Light or Heavy Vacuum Gas Oil and Asphalt, abated by A1 or A3 Mist Eliminator F-8 (or) F-10 and A31 Thermal Oxidizer H-4607. If A31 and the vapor recovery blower are inoperative, S59 emissions shall be contained in a District approved closed vent system as specified in Parts 93 and 96. Alternately, S59 emissions shall be vented to source S24, Hot Oil Heater (H-4603), as a backup until A31 is operating. (cumulative increase)

S63 Kerosene/Light Vacuum Gas Oil/Heavy Vacuum Gas Oil/Asphalt Storage Tank, Fixed Roof, TK-31, Capacity: 1,218,000 Gallons abated by A3 or A20 Mist Eliminator F-10 or F-500 and A31 Thermal Oxidizer H-4607. If A31 and the vapor recovery blower are inoperative, S63 emissions shall be contained in a District approved closed vent system as specified in Parts 94 and 96. Alternately, S63 emissions shall be vented to source S24, Hot Oil Heater (H-4603), as a backup until A31 is operating. (cumulative increase)

30. Petroleum materials other than Kerosene, Light or Heavy Vacuum Gas Oil, and Asphalt may be stored in S13, S59, and S63 if all of the following are satisfied:

- a. the storage of each petroleum material complies with all other conditions applicable to S13, S59, or S63.
 - b. the storage of each petroleum material complies with all other applicable regulatory requirements
 - c. the permittee keeps District approved records which demonstrate to the District's satisfaction that no toxin listed in Table 2-1-316 is emitted from S13, S59, or S63 in an amount in excess of the toxin's respective trigger level set forth in Table 2-1-316.
- (cumulative increase, toxics)

31. The true vapor pressure of each material stored in S13, S59, or S63 shall not exceed 1.5 psia. (cumulative increase, toxics)

31a. To assure compliance with the limit in part II.31, the permit holder shall take a sample from each tank on an annual basis and determine the true vapor pressure of the sample. Records of these analyses shall be retained for at least 5 years from the date of the analysis, shall be kept on site, and shall be made available to the District staff on request. (cumulative increase, toxics)

32a. The owner/operator shall maintain and operate A31 Thermal Oxidizer H-4607 and S24 Hot Oil Heater H-4603; with an overall collection and destruction efficiency of at least 98.5%, by weight whenever petroleum and VOC materials are stored and/or transferred at S3, S5, S6, S7, S8, S13, S25, S31, S37, S38, S41, S51, S52, S53, S54, S59, S60, S61, S62, S63, S65, S66 and S70. (Regulation 8-5-306, NSPS, cumulative increase, BACT, toxics)

32b. Deleted. Combined with Part 32a.

32c. Deleted. Combined with Part 32a

Deleted. Redundant with Regulation 8-18.

32e. To monitor compliance with the standard in 40 CFR 60.112b(a)(3)(i) for fugitive emissions at closed vent systems, the owner/operator shall inspect the closed vent systems that control S13, S59, and S63 using EPA Method 21 on a semi-annual basis. (Regulation 2-6-503)

33a. The total combined throughput of all materials to S13, S59, and S63 shall not exceed 68,208,000 gallons (1,624,600 barrels) in any rolling 12 consecutive month period. (cumulative increase, toxics)

33b. Cutback asphalt materials including but not limited to SC Cutback Asphalt, MC Cutback Asphalt, and FM-1 Cutback Asphalt and other cutback asphalt materials shall NOT be stored in or transferred to S63. (toxics)

34. On a monthly basis, the permittee shall record in a District approved log the total volume of each liquid material throughput to S13, S59, or S63 by material name (e.g., kerosene, light vacuum gas oil, heavy vacuum gas oil, asphalt) each month and each rolling 12 consecutive month period, in gallon units or barrel units. This log shall be retained for at least 5 years from date of entry, shall be kept on site, and shall be made available to the District staff on request. (cumulative increase)

35. Deleted May, 2001

36. Deleted May, 2001

37. Deleted May, 2001

38. Deleted May, 2001

39. Deleted May, 2001

S3 Fixed Roof Storage Tank, TK-1C, Storing: Heavy Vacuum Gas Oil, Capacity: 3,415,000 Gallons operated with a District approved vapor recovery system and abated by (either) A3 or A20 Mist Eliminator F-10 or F-500 and A31 Thermal Oxidizer H-7. If A31 and the vapor recovery blower are inoperative, S3 emissions shall be contained in a District approved closed vent system as specified in Parts 94 and 96. Alternately, S3 emissions shall be vented to source S24, Hot Oil Heater (H-4603), as a backup until A31 is operating. (cumulative increase)

40. Materials other than Heavy Gas Oil may be stored in S3, if all of the following are satisfied:

a. the storage of each petroleum material complies with all other conditions applicable to S3

- b. the storage of each petroleum material complies with all other applicable regulatory requirements
- c. the permittee keeps District approved records that demonstrate to the District's satisfaction that no toxin listed in Table 2-1-316 is emitted from S3 in an amount in excess of the toxin's respective trigger level set forth in Table 2-1-316. (cumulative increase, toxics)

41. The permittee shall ensure that at least 38,300,000 gallons (the 1996 calendar year baseline throughput to S3) of gas oil is throughput exclusively to S3 for storage during every rolling 12 consecutive month period, prior to transferring/storing gas oil material into another vessel for which VOC emissions are not abated with a destruction efficiency of at least 98.5%, by weight. (offsets)

42. The true vapor pressure of each and all material stored in S3 shall not exceed 0.5 psia. (cumulative increase, NSPS)

43. Deleted. Combined with Part 32a.
Deleted. Redundant with Regulation 8-18.

45. All tank fittings present at S3 shall be gasketed. (BACT)

46. At the conclusion of each month, the permittee shall record in a District approved log the total volume of each and all liquid materials throughput to S3 during that month and for each rolling 12 consecutive month period, in gallon units or barrel units. This log shall be retained for at least 5 years from date of entry, shall be kept on site, and shall be made available to the District staff on request. (cumulative increase)

47. Deleted 11/29/99. Start-up condition

S5 Asphalt Storage Tank, Fixed Roof, TK-2A, Capacity: 3,415,000 Gallons abated by either A1 or A3 Mist Eliminator F-8 or F-10 and A31 Thermal Oxidizer H-4607. If A31 and the vapor recovery blower are inoperative, S5 emissions shall be contained in a District approved closed vent system as specified in Parts 93 and 96. Alternately, S5 emissions shall be vented to source S24, Hot Oil Heater (H-4603), as a backup until A31 is operating. (cumulative increase)

S6 Asphalt Storage Tank, Fixed Roof, TK-2B, Capacity: 3,415,000 Gallons abated by either A1 or A3 Mist Eliminator F-8 or F-10 and A31 Thermal Oxidizer H-4607. If A31 and the vapor recovery blower are inoperative, S6 emissions shall be contained in a District approved closed vent system as specified in Parts 93 and 96. Alternately, S6 emissions shall be vented to source S24, Hot Oil Heater (H-4603), as a backup until A31 is operating. (cumulative increase)

S7 Asphalt Storage Tank, Fixed Roof, TK-3, Capacity: 1,050,000 Gallons abated by either A1 or A3 Mist Eliminator F-8 or F-10 and A31 Thermal Oxidizer H-4607. If A31 and the vapor recovery blower are

inoperative, S7 emissions shall be contained in a District approved closed vent system as specified in Parts 93 and 96. Alternately, S7 emissions shall be vented to source S24, Hot Oil Heater (H-4603), as a backup until A31 is operating. (cumulative increase)

S8 Asphalt Storage Tank, Fixed Roof, TK-4, Capacity: 1,050,000 Gallons abated by either A1 or A3 Mist Eliminator F-8 or F-10 and A31 Thermal Oxidizer H-4607. If A31 and the vapor recovery blower are inoperative, S8 emissions shall be contained in a District approved closed vent system as specified in Parts 93 and 96. Alternately, S8 emissions shall be vented to source S24, Hot Oil Heater (H-4603), as a backup until A31 is operating. (cumulative increase)

S37 Asphalt Storage Tank, Fixed Roof, TK 54, Capacity: 100,000 Gallons abated by A3 or A20 Mist Eliminator F-10 or F-500 and A31 Thermal Oxidizer H-4607. If A31 and the vapor recovery blower are inoperative, S37 emissions shall be contained in a District approved closed vent system as specified in Parts 94 and 96. Alternately, S37 emissions shall be vented to source S24, Hot Oil Heater (H-4603), as a backup until A31 is operating. (cumulative increase)

S38 Asphalt Storage Tank, Fixed Roof, TK-55, Capacity: 100,000 Gallons abated by A3 or A20 Mist Eliminator F-10 or F-500 and A31 Thermal Oxidizer H-4607. If A31 and the vapor recovery blower are inoperative, S38 emissions shall be contained in a District approved closed vent system as specified in Parts 94 and 96. Alternately, S38 emissions shall be vented to source S24, Hot Oil Heater (H-4603), as a backup until A31 is operating. (cumulative increase)

S51 Asphalt Storage Tank TK-506; Fixed Roof Tank, Capacity: 152,880 Gallons abated by A3 or A20 Mist Eliminator F-10 or F-500 and A31 Thermal Oxidizer H-4607. If A31 and the vapor recovery blower are inoperative, S51 emissions shall be contained in a District approved closed vent system as specified in Parts 94 and 96. Alternately, S51 emissions shall be vented to source S24, Hot Oil Heater (H-4603), as a backup until A31 is operating. (cumulative increase)

S52 Asphalt Storage Tank TK 507, Fixed Roof Tank, Capacity: 152,880 Gallons abated by A3 or A20 Mist Eliminator F-10 or F-500 and A31 Thermal Oxidizer H-4607. If A31 and the vapor recovery blower are inoperative, S52 emissions shall be contained in a District approved closed vent system as specified in Parts 94 and 96. Alternately, S52 emissions shall be vented to source S24, Hot Oil Heater (H-4603), as a backup until A31 is operating. (cumulative increase)

S53 Asphalt Storage Tank TK 508, Fixed Roof Tank, Capacity: 152,880 Gallons abated by A3 or A20 Mist Eliminator F-10 or F-500 and A31 Thermal Oxidizer H-4607. If A31 and the vapor recovery blower are inoperative, S53 emissions shall be contained in a District approved closed vent system as specified in Parts

94 and 96. Alternately, S53 emissions shall be vented to source S24, Hot Oil Heater (H-4603), as a backup until A31 is operating. (cumulative increase)

S60 Asphalt Storage Tank TK-505; Fixed Roof, Capacity: 15,000 Gallons abated by (either) A3 or A20 Mist Eliminator F-10 or F-500 and A31 Thermal Oxidizer H-4607. If A31 and the vapor recovery blower are inoperative, S60 emissions shall be contained in a District approved closed vent system as specified in Parts 94 and 96. Alternately, S60 emissions shall be vented to source S24, Hot Oil Heater (H-4603), as a backup until A31 is operating. (cumulative increase)

S61 Asphalt Storage Tank, Fixed Roof, TK-30A, Capacity: 995,400 Gallons abated by A3 or A20 Mist Eliminator F-10 or F-500 and A31 Thermal Oxidizer H-4607. If A31 and the vapor recovery blower are inoperative, S61 emissions shall be contained in a District approved closed vent system as specified in Parts 94 and 96. Alternately, S61 emissions shall be vented to source S24, Hot Oil Heater (H-4603), as a backup until A31 is operating. (cumulative increase)

S62 Asphalt Storage Tank, Fixed Roof, TK-30B, Capacity: 995,400 Gallons abated by A3 or A20 Mist Eliminator F-10 or F-500 and A31 Thermal Oxidizer H-4607. If A31 and the vapor recovery blower are inoperative, S62 emissions shall be contained in a District approved closed vent system as specified in Parts 94 and 96. Alternately, S62 emissions shall be vented to source S24, Hot Oil Heater (H-4603), as a backup until A31 is operating. (cumulative increase)

S65 Asphalt Storage Tank, Fixed Roof, TK-32 Tank Capacity: 6,920,000 Gallons abated by A3 or A20 Mist Eliminator F-10 or F-500 and A31 Thermal Oxidizer H-4607. If A31 and the vapor recovery blower are inoperative, S65 emissions shall be contained in a District approved closed vent system as specified in Parts 94 and 96. Alternately, S65 emissions shall be vented to source S24, Hot Oil Heater (H-4603), as a backup until A31 is operating. (cumulative increase)

S70 Asphalt Additive Mixing Tank, Fixed Roof, Tank Capacity: 2,200 Gallons abated by A3 or A20 Mist Eliminator F-10 or F-500 and A31 Thermal Oxidizer H-4607. If A31 and the vapor recovery blower are inoperative, S70 emissions shall be contained in a District approved closed vent system as specified in Parts 94 and 96. Alternately, S70 emissions shall be vented to source S24, Hot Oil Heater (H-4603), as a backup until A31 is operating. (cumulative increase)

48. The sum total asphalt throughput to S5, S6, S7, S8, S37, S38, S51, S52, S53, S60, S61, S62, and S65 shall not exceed 6,738,349 barrels (283,010,658 gallons) in any 12 consecutive month period. (cumulative increase, offsets)

49. For S5, S6, S7, S8, S37, S38, S51, S52, S53, S60, S61, S62, S65, S70: Cutback asphalt materials including but not limited to SC Cutback Asphalt, MC Cutback Asphalt, and FM-1 Cutback Asphalt and other cutback asphalt materials shall not be stored in or transferred to any of the above tanks. (toxics)

50. For S5, S6, S7, S8, S37, S38, S51, S52, S53, S60, and S70: the true vapor pressure of each and all materials stored in each tank shall not exceed 0.5 psia. (cumulative increase, offsets)

51. For S61 and S62, the true vapor pressure of each and all materials stored in each tank shall not exceed 0.49 psia. (cumulative increase, offsets, NSPS, BACT)

52. For S65, the true vapor pressure of each and all materials stored in S65 shall not exceed 0.49 psia. (cumulative increase, offsets, BACT)

Deleted. Redundant with Regulation 8-18.

54. Deleted May, 2001.

55. Deleted. Combined with Part 32a

56. Deleted. Combined with Part 32a

57. Deleted. Combined with Part 32a

58. Separately, for each of S5, S6, S7, S8, S37, S38, S51, S52, S53, S60, S61, S62 S65, and S70, at the conclusion of each month, the permittee shall record, by material name, in a District approved log, the total volume of each liquid material throughput to each tank during that month and during each rolling 12 consecutive month period, in gallon units or barrel units. This log shall be retained for at least 5 years from date of entry, shall be kept on site, and shall be made available to the District staff on request. (cumulative increase)

58a. Deleted Application 17468.

58b. The Owner/Operator shall install and properly maintain continuous temperature monitoring and recording devices for A31, Thermal Oxidizer (H-4607) and S24, Hot Oil Heater (H-4603). The Owner/Operator shall operate A-31 with a minimum combustion zone temperature of 1400F to maintain a 98.5% destruction efficiency, whenever emissions are vented to it by one or more operational vapor recovery blowers in organic vapor service. The Owner/Operator shall operate S-24 at a minimum operating temperature of 1115F to maintain a 98.5% destruction efficiency, whenever emissions are vented to it by one or more vapor recovery blowers in organic vapor service. (Source Test Requirements demonstrating compliance with the 98.5% abatement destruction efficiency and the Regulation 6-310 grain loading requirements were completed February 28 and 29, 2004.) (Applications 12704 for A-31 and Application 12236 for S-24 have been submitted for the Title V permit revisions) (Basis: 40 CFR 60.113b(c)(1)(ii) and 60.113b(c)(2); 40 CFR 60.473c; 40 CFR 61.354(c)(1); 40 CFR 61.354(c)(4), Regulation 2-6-409.2.2, 2-6-414)

58c. The temperature limit in Part II.58b for A-31 shall not apply during an “Allowable Temperature Excursion”, provided that the temperature controller set point remains at a minimum of 1,400°F. An Allowable Temperature Excursion is one of the following:

- a. A temperature excursion not exceeding 20°F; or
- b. A temperature excursion for a period or periods which when combined are less than or equal to 15 minutes in any hour; or
- c. A temperature excursion for a period or periods which when combined are more than 15 minutes in any hour, provided that all three of the following criteria are met.
 - i. the excursion does not exceed 50°F;
 - ii. the duration of the excursion does not exceed 24 hours; and
 - iii. the total number of such excursions does not exceed 12 per calendar year (or any consecutive 12 month period).

Two or more excursions greater than 15 minutes in duration occurring during the same 24-hour period shall be counted as one excursion toward the 12 excursion limit. (basis: Regulation 2-1-403)

58d. For each Allowable Temperature Excursion that exceeds 20°F. and 15 minutes in duration, the Permit Holder shall keep sufficient records to demonstrate that they meet the qualifying criteria described above. Records shall be retained for a minimum of five years from the date of entry, and shall be made available to the District upon request. Records shall include at least the following information:

- a. Temperature controller setpoint;
- b. Starting date and time, and duration of each Allowable Temperature Excursion;
- c. Measured temperature during each Allowable Temperature Excursion;
- d. Number of Allowable Temperature Excursions per month, and total number for the current calendar year; and
- e. All strip charts or other temperature records.

58e. For the purposes of parts II.58c and II.58d, a temperature excursion refers only to temperatures below the limit. (basis: Regulation 2-1-403)

58f. For the purposes of parts II.58c and II.58d, a temperature excursion occurs only when one or more vapor recovery system blowers is operating in organic vapor service, and is vented to A-31. When a blower is used to start up A-31, the blower is in “fresh air” service and not in organic vapor service, until A-31 meets the minimum operating temperature and is acceptable to receive organic vapors. (basis: Regulation 2-1-403)

S14 Naphtha Loading Racks abated by A4 Thermal Oxidizer H-6

59. S14 shall be operated with a submerged fill pipe and be abated by A4 Thermal Oxidizer H-6 at all times that materials are transferred at S14. (cumulative increase, offsets, BACT, toxics)

59a. To monitor compliance with the standard in BAAQMD Regulation 8-6-306 for vapor tightness of equipment associated with organic liquid delivery and

loading operations at S14, the owner/operator shall inspect the equipment using EPA Method 21 on a quarterly basis. (Regulation 2-6-503)

59b. To monitor compliance with the standard in BAAQMD Regulation 8-6-306 for leak-free equipment associated with organic liquid delivery and loading operations at S14, the owner/operator shall inspect the equipment on a quarterly basis. This condition shall be effective on April 1, 2004. (Regulation 2-6-503)

60. S14 emissions shall be captured by a District approved vapor recovery system and shall be abated by A4 Thermal Oxidizer H-6 with a destruction efficiency of at least 98.5%, by weight, as measured across A4. (cumulative increase, offsets, BACT, toxics)

61a. The true vapor pressure of the materials transferred at S14 shall not exceed 11 psia. (cumulative increase, offsets, toxics)

61b. The total throughput of naphtha to S14 shall not exceed 25,749,000 gallons (613,000 barrels) during any consecutive 12-months. (cumulative increase)

S15 Kerosene and Light Vacuum Gas Oil Loading Rack abated by A4 Thermal Oxidizer H-6

62. S15 shall be operated with a submerged fill pipe and be abated by A4 Thermal Oxidizer H-6 at all times that materials are transferred at S15. (cumulative increase, offsets, BACT, toxics)

62a. To monitor compliance with the standard in BAAQMD Regulation 8-6-306 for vapor tightness of equipment associated with organic liquid delivery and loading operations at S15, the owner/operator shall inspect the equipment using EPA Method 21 on a quarterly basis. (Regulation 2-6-503)

62b. To monitor compliance with the standard in BAAQMD Regulation 8-6-306 for leak-free equipment associated with organic liquid delivery and loading operations at S15, the owner/operator shall inspect the equipment on a quarterly basis. (Regulation 2-6-503)

63. S15 emissions shall be captured by a District approved vapor recovery system and shall be abated by A4 Thermal Oxidizer H-6 with a destruction efficiency of at least 98.5%, by weight, as measured across A4. (cumulative increase, offsets, BACT, toxics)

64a. The true vapor pressure of the materials transferred at and/or sampled from S15 shall not exceed 1.5 psia. All materials loaded at S15 must be transferred from Tanks S13, S59, or S63. (cumulative increase, offsets, toxics)

64b. The total combined throughput of Kerosene and Light Vacuum Gas Oil to S15, shall not exceed 283,011,000 gallons (1,483,000 barrels) during any consecutive 12-months. (cumulative increase, offsets, toxics)

S17 Asphalt Loading Racks abated by A2 Mist Eliminator F-9 and A4 Thermal Oxidizer H-6

S31 Rail Car Loading Rack; 5 Loading Arms, Loading: Asphalt and Light Vacuum Gas Oil abated by A6 Mist Eliminator F-3 and A31 Thermal Oxidizer H-4607. If A31 and the vapor recovery blower are inoperative, S31 emissions shall be contained in a District approved closed vent system as specified in Parts 94 and 96. Alternately, S31 emissions shall be vented to source S24, Hot Oil Heater (H-4603), as a backup until A31 is operating. (cumulative increase)

S54 Asphalt Loading Rack abated by (either) A3 or A20 Mist Eliminator F-10 or F-500 and A31 Thermal Oxidizer H-4607. If A31 and the vapor recovery blower are inoperative, S54 emissions shall be contained in a District approved closed vent system as specified in Parts 94 and 96. Alternately, S54 emissions shall be vented to source S24, Hot Oil Heater (H-4603), as a backup until A31 is operating. (cumulative increase)

65. S17 shall be abated by A2 Mist Eliminator F-9 and A4 Thermal Oxidizer H-6 at all times that materials are transferred at S17. (cumulative increase)

[Deleted. Combined with Part 64b] [Deleted. Combined with part 64b]

68. Emissions from S17 shall be captured by a District approved vapor recovery system and shall be abated by A2 Mist Eliminator F-9 and A4 Thermal Oxidizer H-6 with a destruction efficiency of at least 98.5%, by weight, as measured across A4. (cumulative increase, BACT)

69. Deleted Combined with Part 32a.

70. Deleted. Combined with Part 32a.

71. The true vapor pressure of the materials transferred at or sampled from S17 and/or S 54 shall not exceed 0.5 psia except for 5,500 Barrels per year of kerosene when required to produce medium-cure cutback asphalt products. (cumulative increase, offsets)

72. The true vapor pressure of the materials transferred at or sampled from S31 shall not exceed 1.5 psia, unless the material contains asphalt. (cumulative increase, toxics, offsets)

72a. To monitor compliance with the standard in BAAQMD Regulation 8-6-306 for vapor tightness of equipment associated with organic liquid delivery and loading operations at S31, the owner/operator shall inspect the equipment using EPA Method 21 on a quarterly basis. (Regulation 2-6-503)

72b. To monitor compliance with the standard in BAAQMD Regulation 8-6-306 for leak-free equipment associated with organic liquid delivery and loading operations at S31, the owner/operator shall inspect the equipment on a quarterly basis. (Regulation 2-6-503)

73. If asphalt or any asphalt containing material or any material blended with asphalt is transferred at or sampled from S31, the true vapor of the material may not exceed 0.5 psia. (cumulative increase, toxics, offsets)

74. The total combined throughput of asphalt and all asphalt containing materials to S17, S31, and S54 shall not exceed 283,011,000 gallons during any consecutive 12-months. (cumulative increase, offsets)

75. The permittee shall maintain a District approved log of the monthly throughput of asphalt and all asphalt containing materials to S17, S31, and S54 in gallon units or barrel units during each month and during each rolling 12 consecutive month period, in gallon units or barrel units. This log shall be retained for at least 5 years from date of entry, shall be kept on site, and shall be made available to the District staff on request. (cumulative increase)

76. Deleted May, 2001.

77. Deleted May, 2001.

78. Deleted May, 2001.

79. Deleted May, 2001.

80. Deleted May, 2001.

81. Deleted May, 2001.

82. Deleted May, 2001.

S66 Oil Water Separator, Physical Capacity: 830 GPM, Permitted Capacity: 210 GPM abated by (either) A1 or A3 Mist Eliminator F-8 or F-10 and A31 Thermal Oxidizer H-4607. If A31 and the vapor recovery blower are inoperative, S66 emissions shall be contained in a District approved closed vent system as specified in Parts 93 and 96. Alternately, S66 emissions shall be vented to source S24, Hot Oil Heater (H-4603), as a backup until A31 is operating. (cumulative increase)

83. The permittee shall ensure that the throughput of liquid material to S66 shall not exceed 110,376,000 gallons per year (210 gallons per minute). (basis: cumulative increase)

84. The cover and each access opening at S66 shall be equipped with a gasketed, vapor tight cover (as defined in Regulation 8, Rule 8). Each cover and access opening shall be kept closed and sealed except when the opening is being used for inspection, maintenance, or wastewater sampling. (basis: Reg. 8, Rule 8)

85. Deleted. Combined with Part 32a.

Deleted. Redundant with Regulation 8-18.

87. Not less frequently than on a monthly basis, the permittee shall measure and record the volume (in gallons) of oil (slop oil) product recovered at S66 and not less frequently than on a monthly basis, the permittee shall measure and record the volume (in gallons) of waste water product recovered at S66 (waste water discharge to City of Benicia). The sum of the volume of slop oil product and the volume of wastewater product shall recorded in a District approved log as the throughput of liquid material to S66. (basis: cumulative increase)

88. On a monthly basis, the permittee shall record in a District approved log the total volume of all liquid materials throughput to S66 each month, in gallon units or barrel units. This log shall be retained for at least 5 years from date of entry, shall be kept on site, and shall be made available to the District staff on request. (basis: cumulative increase)

89. Deleted 2001.

S16 Truck Loading Rack-Heavy Vacuum Gas Oil

90. The true vapor pressure of the materials transferred at and/or sampled from S16 shall not exceed 0.49 psia. (cumulative increase)

91. The total throughput of materials transferred through S16 shall not exceed 25,749,000 gallons (613,000 barrels) during any consecutive 12-months. (cumulative increase)

91a. The permittee shall maintain a District approved log of the monthly throughput of materials transferred at S16 in gallon units or barrel units during each month and during each rolling 12 consecutive month period, in gallon units or barrel units. This log shall be retained for at least 5 years from date of entry, shall be kept on site, and shall be made available to the District staff on request. (cumulative increase)

S41, Wemco Hydrocleaner Induced Air Flotation Machine, abated by A1 or A3 Mist Eliminator F-8 or F-10 and S24 Hot Oil Furnace H-3 or A31 Thermal Oxidizer.

92. The permittee shall ensure that the throughput of liquid material to S41 shall not exceed 77,263,200 gallons per year (147 gallons per minute). (basis: cumulative increase)

92a. The permittee shall maintain a District approved log of the monthly throughput of liquid material transferred to S41 in gallon units during each month and during each rolling 12 consecutive month period. This log shall be retained for at least 5 years from date of entry, shall be kept on site, and shall be made available to the District staff on request. (cumulative increase)

93. The following sources, which shall be operated with a District approved closed vent system, are connected to vapor recovery collection header #1 and vapor recovery blower B-4608 or spare blower B-46501: S5, S6, S7, S8, S25,

S41, S59, and S66. Emissions are contained in the closed vent collection header whenever a blower is not operating, as long as no P/V valve in the header is lifting. The pressure of each of the three headers at a representative location shall be monitored at least once every 8 hours, whenever the vapor recovery blower is not operating. If the manometer pressure of any header exceeds 0.5 ounces (0.87 inches of water column), A-31 or S-24 shall be restarted and emissions conveyed to it by the blower. (basis: cumulative increase)

94. The following sources, which shall be operated with a District approved closed vent system, are connected to vapor recovery collection header #2 and vapor recovery blower B-46500 or spare blower B-46501: S3, S13, S37, S38, S51, S52, S53, S54, S60, S61, S62, S63, S65, and S70. Emissions are contained in the closed vent collection header whenever a blower is not operating, as long as no P/V valve in the header is lifting. The pressure of the each of the three headers at a representative location shall be monitored at least once every 8 hours, whenever the vapor recovery blower is not operating. If the manometer pressure of any header exceeds 0.5 ounces (0.87 inches of water column), A-31 or S-24 shall be restarted and emissions conveyed to it by the blower. (basis: cumulative increase)

95. To determine compliance with Parts 93 and 94, the owner/operator shall maintain the following records and provide all of the data necessary to evaluate compliance with the above parts, including the following information:

- All manometer pressures of each of the three headers abated by A-31 or S-24
- Date and time when the blower is down and which abating equipment (A-31, closed vent system or S-24) is in operation
- Reason why the blower is down

All records shall be retained on-site for at least five years, from the date of entry, and made available for inspection by District staff upon request. These recordkeeping requirements shall not replace the recordkeeping requirements contained in any applicable District Regulations. (basis: cumulative Increase)

96. The owner/operator of S3, S5, S6, S7, S8, S12, S13, S25, S26, S27, S28, S31, S37, S38, S-39, S40, S41, S51, S52, S53, S54, S59, S60, S61, S62, S63, S65, S66, S67 and S70 shall not use any P/V valve that leaks total organic compounds in excess of 500 ppmv when the vapor recovery blower is not operating. Any exceedance of this limit will result in a violation, except for P/V valve that is subject to Regulation 8-18 and is already on the non-repairable list. (basis: to allow the use of closed vent system in lieu of A-31 or S-24)

III. MARINE OPERATIONS CONDITIONS-S30, Part 1 through 9, deleted because S30 was not in service since April 5, 2005
(Cumulative Increase)

IV. ODOR REDUCTION MEASURES (Added per AN 14513, 9/95)

*1. The permit holder will maintain water seals, P-traps, caps, covers or equivalent on all process water drains. (1-301)

*2. The permit holder will implement an Asphalt Tank Truck Dome Inspection Program for all asphalt tank trucks that they load. If a truck enters the facility with a leaking or malfunctioning dome lid, the permit holder will take the following action.

*a. First occurrence in rolling twelve month period: the permit holder will orally notify the truck driver and dispatcher of the faulty dome lid, and request that the lid be repaired prior to the truck re-entering the facility.

*b. Second occurrence in a rolling twelve month period: the permit holder will notify the driver and the trucking company in writing that if the truck enters the facility again with a malfunctioning dome hatch, the permit holder will not load the truck until the hatch has been repaired.

*c. Third occurrence in a rolling twelve-month period: the permit holder will not load the truck. The permit holder will also notify the driver and dispatcher, verbally and in writing, that the truck will not be loaded until the hatch has been repaired, and the repair has been inspected or repair documentation has been received by the permit holder to ensure that the hatch is in proper working order.

*The permit holder shall keep records of all inspections and notifications. These records shall be made available to the District upon request.
(1-301)

*3. The permit holder shall provide written notification of the Asphalt Tank Truck Dome Inspection Program to any additional trucking company that may do business with the permit holder in the future, within two weeks of the first asphalt receipt. (1-301)

V. OTHER SOURCES

S24 Hot Oil Heater H-3; Max Firing Rate 9 MM BTU/hr

1. Respective emissions of nitrogen oxides, and carbon monoxide (CO) from S24 shall not exceed 30 ppm and 50 ppm at 3% O₂. (Cumulative Increase)

Condition 20278

For Sources S69, Asphalt Additive Loading Bin, and S70, Asphalt Additive Mixing Tank

1. The annual throughput of asphalt (excluding additives) at S-70 shall not exceed 400,000 tons during any consecutive 12-month period. (Basis: Regulation 2-2-212, Cumulative Increase)
2. The annual throughput of additives at S-69 shall not exceed 20,000 tons during any consecutive 12-month period. (Basis: Regulation 2-2-212, Cumulative Increase)
3. Deleted. Combined with Condition #1240, Part 47.
- *4. Visible dust and smoke emissions from S-69 and S-70 shall not result in fallout on adjacent property in such quantities so as to cause a public nuisance as described in Regulation 1-301 (Basis: Regulation 1)

5. Deleted 2004 reopening.
6. In order to demonstrate compliance with the above permit conditions, the following records shall be maintained in a District approved log. These records shall be kept on site and made available for District inspection for a period of at least 5 years from the date on which a record is made.
 - a. Total daily throughput of modified asphalt at S-70 and additives at S-69
 - b. Deleted 2004 reopening.
 - c. The daily throughput of product shall be totaled on a monthly basis.
 - d. Results of all visible emissions checks and any corrective action
(Basis: Regulation 2-6-501)
7. A visible emissions check shall be performed on S69 on an annual basis. The visible emissions check shall take place while the equipment is operating and during daylight hours. If any visible emissions are detected, the operator shall take corrective action, and check for visible emissions the next time that the equipment is operated. If no visible emissions are detected, the operator shall continue to check for visible emissions on an annual basis.
(basis: 2-6-409.2)

IX. RECOMMENDATION

Issue a conditional change to the Permit to Operate to Valero Refining Company for the following equipment:

Abatement Devices:

A-31 H-4607 Thermal Oxidizer, 3.5 MMBtu/hr

S-24 H-4603 Hot Oil Heater, 9.0 MMBtu/hr

Abated Sources:

S-3 TK-1C Gas Oil Tank

S-5 TK-2A Asphalt Tank

S-6 TK-2B Asphalt Tank

S-7 TK-3 Asphalt tank

S-8 TK-4 Asphalt Tank

S-13 TK-8 Kerosene Tank

S-25 TK-11A WWTP Effluent Water Tank (to be archived)

S-31 Asphalt/Gas Oil Rail Car Loading Rack

- S-37 TK-54 Rubberized Asphalt Sales Tank**
- S-38 TK-55 Rubberized Asphalt Sales Tank**
- S-41 Wemco Hydrocleaner**
- S-51 TK-506 Asphalt Sales Tank**
- S-52 TK-507 Asphalt Sales Tank**
- S-53 TK-508 Asphalt Sales Tank**
- S-54 TK-Asphalt Truck Loading Rack**
- S-59 TK-5 Gas Oil Tank**
- S-60 TK-505 Asphalt Tank**
- S-61 TK-30A Asphalt Tank**
- S-62 TK-30B Asphalt Tank**
- S-63 TK-31 Kero/LVGO/HVGO/Asphalt Tank**
- S-65 TK-32 Asphalt Tank**
- S-66 WWTP Oil-Water Separator**
- S-70 TK-500 Asphalt Additive Mixing Tank**

Thu H. Bui
Senior Air Quality Engineer
Engineering Division
Date:

THB:T\ValeroAsphalt\19384e

**EVALUATION REPORT
VALERO REFINING CO.
Application #19631- Plant #13193**

**3001 Park Road
Benicia, CA 94510**

I. BACKGROUND

Valero has submitted this application (A/N 19631) together with an associated Title V application (A/N 19643) to revise both permits with respect to the Benzene Waste Operations NESHAP (40 CFR 61 Subpart FF).

- A. This application includes a request to surrender the Permit to Operate for the following wastewater equipment, which is being taken out of service permanently.

S-25 Effluent Wastewater Tank, TK-4611A

- B. This application requests exemptions for the following wastewater tanks and requests that their names be changed as shown below. These tanks contain wastewater that is suitable for discharge. This wastewater contains less than 1% hydrocarbon. Therefore the tanks are exempt from permitting in accordance with Regulation 2-1-123.3.

S-12 Effluent Wastewater Tank, TK-4606

S-26 Effluent Wastewater Tank, TK-4613

S-28 Effluent Wastewater Tank, TK-4611B

- C. This application also includes a request for a change of condition to the Authority to Construct/Permit to Operate for the following equipment (Condition 1240, Part II.58b) to reflect the changes requested in the Title V application:

A-31 Thermal Oxidizer, H-4607

S-24 Hot Oil Heater, H-4603 (natural gas)

- D. The Title V application (A/N 19643) proposes to incorporate the changes to the permit conditions as requested in this application and to modify the applicable requirements for the Benzene Waste Operations NESHAP (40 CFR 61 Subpart FF) in the Facility A0901 Title V Permit to reflect the compliance option selected by Valero for the Benicia Asphalt Plant. The requirements for the following sources will be modified:

S-9 Naphtha Tank, TK-4607

S-12 Effluent Wastewater Tank, TK-4606

S-24 Hot Oil Heater, H-4603 (natural gas)

S-26 Effluent Wastewater Tank, TK-4613

S-27 Recovered Oil Tank, TK-4612A

S-28 Effluent Wastewater Tank, TK-4611B

S-41 WEMCO Hydrocleaner

S-66 Oil-Water Separator

S-67 Recovered Oil Tank, TK-4612B

**A-31 Thermal Oxidizer, H4606
Fugitive Components
Sitewide**

Valero has elected to comply with the Treat to 6 (6BQ) compliance option at 40 CFR 61.342(e) for the Benzene Waste Operations NESHAP, 40 CFR 61 Subpart FF. Valero complies with the regulation for the Refinery (B2626), the Asphalt Plant (A0901), and the Valero-operated, NuStar-owned tanks (B5574) as a single consolidated facility.

In the 6BQ compliance option, the facility must control all non-aqueous waste streams from their point of generation until they are either treated to remove the benzene to specified levels or until the waste is recycled to the process [61.342(e)(1)]. The facility may elect not to control their aqueous waste streams ($\geq 10\%$ water) as long as the total benzene in the uncontrolled waste streams does not exceed 6 Mg/year [61.342(e)(2)]. To comply, the facility must identify each benzene waste stream subject to the regulation, determine whether the waste stream is to be controlled or uncontrolled, determine the quantity of each waste stream and the benzene concentration in each waste stream at the point of generation, and calculate the total annual amount of benzene in the facility's waste (TAB). The total annual benzene in the uncontrolled waste streams is also tabulated separately and reported as the target benzene quantity or TBQ for compliance with 61.342(e)(2). The TBQ must not exceed 6 Mg/year. The regulation specifies the allowable methods for determining the waste stream quantities and benzene concentrations and for calculating the TAB and TBQ for each waste stream in 61.355 (Test methods, procedures, and compliance provisions). The methodology for determining the total annual benzene (TAB) is found in 61.355 with paragraphs 61.355(a), (b), and (c) applying to the Valero Benicia facilities. The methodology for determining the target benzene quantity (TBQ) for compliance with 61.342(e)(2) is found in 61.355(k). Valero estimates the TAB and TBQ quarterly and projects the TBQ annually each quarter to verify that they remain on track to comply with the 6 Mg/year limit. Each year, Valero reviews and updates the list of benzene waste streams at the facilities and the benzene quantification data for each waste stream to determine the TAB and TBQ for that year. Both the TAB and the TBQ are kept in a record and are reported in the annual report as required in 61.356 and 61.357. Attached is the 2008 example of the annual NESHAP Benzene Waste Operations report for Valero Benicia Refinery and Benicia Asphalt Plant to the District and EPA

Each controlled waste stream must be managed in waste management units (individual drain systems, tanks, oil-water separators, treatment systems, containers, closed vent systems, and control devices) that comply with the waste management unit standards in 61.343 through 61.347 and the closed vent system and control device standards in 61.349. To comply with the standards for the waste management units and the closed vent systems and control devices, the facility must perform periodic inspections as required in 61.343 through 61.349. They must monitor the operation of the waste management units and the control devices in 61.354, and must perform recordkeeping and reporting as required in 61.356 and 61.357, respectively.

Detailed records must be kept for each waste stream subject to the regulation as required in 61.356(b). If treatment units are used, then records must be kept, including design information and performance test records. If control devices are used, then records must be kept, including design information and performance test records. Specific records are required for specific types of control devices as specified in 61.356(f). Records must be kept per 61.356(g) for each periodic (quarterly) inspection required by 61.343 through 61.347 that identifies a problem. Records must be kept per 61.356(h) for each annual test of no detectable emissions required by 61.343 through 61.347 and 61.349. Records must be kept per 61.356(j) for each control device operation.

Reporting requirements for facilities with a TAB equal to or greater than 10 Mg/year are specified in 61.357(d). An annual report is required per 61.357(d)(2) and (d)(5). The annual report must contain the TAB and waste stream data specified in 61.357(a)(1) through (a)(3), and, for compliance with 61.342(e), a table of information for each waste stream as specified in 61.357(d)(5). A quarterly report is required per 61.357(d)(6) and (d)(7). The quarterly report must certify that the required inspections have been completed as required per 61.357(d)(6) and must contain the information specified in 61.357(d)(7) for the affected units.

The benzene waste streams generated at the Benicia Asphalt Plant (BAP) that flow to the Oil-Water Separator (S-66) and the WEMCO Hydrocleaner (S-41) through the wastewater sewer are aqueous streams and are managed in accordance with 40 CFR 61.342(e)(2), which allows these waste streams to be uncontrolled. Therefore, the individual drain systems, tanks, and oil-water separators in which these aqueous wastes are managed are not subject to the control standards in 40 CFR 61 Subpart FF and their abatement devices (A-31 and S-24) are not subject to the standards for control devices in 40 CFR 61 Subpart FF. This application (A/N 19631) requests removal of the 40 CFR 61 Subpart FF citations from the basis of Permit Condition 1240, Part II.58b for A-31 and S-24 because those control devices are not used for any source to comply with 40 CFR 61 Subpart FF. This change will also be incorporated in the Title V permit. The associated Title V permit application (A/N 19643) requests that the 40 CFR 61 Subpart FF requirements be removed from the sources in which the uncontrolled Subpart FF wastes are stored. Figure 1 is the process flow diagram for the wastewater treatment facilities at the Asphalt Plant. Figure 2 shows the location of each source.

As noted in this application, Valero is also permanently mothballing one of the effluent water tanks, S-25 (TK-4611A), and has requested to surrender the permit to operate for that source and to remove that source from all parts of Condition 1240. The other three effluent water tanks (S-12 [TK-4606], S-26 [TK-4613], and S-28 [TK-4611B]) are low vapor pressure tanks containing wastewater suitable for discharge. The water stored in these tanks contains less than 1% hydrocarbon and the tanks are therefore exempt from permitting in accordance with Regulation 2-1-123.2. Valero has requested an exemption for these tanks in this application. The tanks will be moved from the permitted sources table to the exempt sources table in the Title V permit. These tanks are not controlled by A31 and S24 and corrections will be made to the Title V permit to reflect their process configuration and applicable requirements. See attached discharge water analyses.

The naphtha stream produced at BAP is a benzene waste with respect to the BAP process and is subject to 40 CFR 61 Subpart FF. This stream is stored in an internal floating roof tank TK-4607 (S-9) and then pumped to the refinery, where it is recycled to the process. This stream must be managed in accordance with 40 CFR 61.342(e)(1), which requires that the benzene emissions from this stream be controlled from its point of generation until it is recycled to the process. Therefore, the individual drain systems (pipelines) and the tank (S-9) in which this waste stream are managed are subject to the control standards in 40 CFR 61 Subpart FF. The pipelines are subject to the standards in 61.346 and the tank is subject to the standards for tanks in 61.343, which allows compliance with the alternative standards for tanks in 61.351. The alternative standards for tanks require compliance with 40 CFR 60 Subpart Kb for internal floating roof tanks. S-9 is already subject to 40 CFR 60 Subpart Kb as shown in the applicable tables in Section IV and Section VII of the Title V permit. Therefore, the Title V application proposes to add only the applicable 40 CFR 61 Subpart FF requirements to the Section IV and Section VII tables for S-9 and to revise the requirements in the sitewide tables to reflect this change in applicability.

Based on the information provided by Valero and the reasons above, the District's staff has decided to grant Valero the above requests. BACT analysis and emission offsets are not required since there is no emission increase from this application.

II. EMISSION CALCULATIONS

This application will not result in an emission increase.

III. PLANT CUMULATIVE INCREASE SINCE 4/5/1991

There are no net changes to the plant cumulative emissions.

IV. TOXIC SCREENING ANALYSIS

This application will not result in an increase in toxic air contaminant emissions from existing levels. Therefore, a Toxic RSA is not required per Regulation 2-5.

V. BEST AVAILABLE CONTROL TECHNOLOGY

This application will not result in any emission increase from existing levels. Therefore, BACT is not triggered per Regulation 2-2-301.

VI. OFFSETS

This application does not result in emission increases. Therefore, offsets are not needed per Regulation 2-2-302.

VII. STATEMENT OF COMPLIANCE

A. S-9 complies with the following Regulations:

Regulation 8, Rule 5 STORAGE OF ORGANIC LIQUIDS

- 8-5-301 Storage Tank Control Requirements
- 8-5-305 Internal Floating Roof Tank Requirements
- 8-5-320 Floating Roof Tank Fitting Requirements
- 8-5-321 Primary Seal Requirements
- 8-5-322 Secondary Seal Requirements
- 8-5-328 Tank Degassing Requirements
- 8-5-331 Tank Cleaning Requirements

Regulation 10 INCORPORATION OF NSPS BY REFERENCE

- 10-17 NSPS Subpart Kb

Regulation 11, Rule 12 INCORPORATION OF 40 CFR 61 SUBPART FF BY REFERENCE

Condition 1240

- Part I.14 Facility Limits
- Part I.18 Cumulative Increase Monitoring
- Part I.18a NMHC and NO_x estimates
- Part I.18e Estimates of NMHC emissions from wastewater sources

Part I.18j Summary of emissions estimates and reports of non-compliance
Parts II.25, II.26, II.27a, II.28, II.29 Specific requirements for S9

BAAQMD State Implementation Plan
Regulation 8, Rule 5

40 CFR 60 Subpart Kb Requirements for Internal Floating Roof Tanks

40 CFR 61 Subpart FF
61.342(e)(1) Requirements for non-aqueous wastes
61.346 Requirements for individual drain systems
61.351 Requirements for internal floating roof tanks

40 CFR 63 Subpart CC Refinery MACT
63.640(n)(1) Overlap with 40 CFR 60 Subpart Kb for Group 1 Tanks
63.640(n)(8) Exceptions for 40 CFR 60 Subpart Kb compliance

B. S-12, S-26, S-28 – Exempt Effluent Wastewater Tanks comply with the following Regulations

These tanks are exempt from permit in accordance with Regulation 2-1-123.2 since the water stored in these tanks contains less than 1% hydrocarbon.

Regulation 8, Rule 5 STORAGE OF ORGANIC LIQUIDS
8-5-117 Limited exemption, low vapor pressure

Condition 1240
Part I.14 Facility Limits
Part I.18 Cumulative Increase Monitoring
Part I.18a NMHC and NO_x estimates
Part I.18j Summary of emissions estimates and reports of non-compliance

Condition 20762 Vapor pressure requirements for tanks exempt from Regulation 8-5 due to 8-5-117

BAAQMD State Implementation Plan
Regulation 8, Rule 5

The benzene waste stream managed in these sources also complies with the following federal regulations:

40 CFR 63 Subpart CC, Requirements for Group 1 Wastewater Streams

40 CFR 61 Subpart FF, 61.342(e)(2) Uncontrolled aqueous waste streams

C. S27 and S67 – Recovered Oil Tanks comply with the following Regulations

Regulation 8, Rule 8 WASTEWATER COLLECTION AND SEPARATION SYSTEMS
8-8-305.2 Oil water separator and air flotation unit slop oil vessels; organic compound vapor recovery system with efficiency $\geq 95\%$

Condition 1240

- Part I.14 Facility Limits
- Part I.18 Cumulative Increase Monitoring
- Part I.18a NMHC and NO_x estimates
- Part I.18e Estimates of NMHC emissions from wastewater sources
- Part I.18j Summary of emissions estimates and reports of non-compliance

BAAQMD State Implementation Plan
Regulation 8, Rule 8

The benzene waste stream managed in these sources also complies with the following federal regulations:

- 40 CFR 63 Subpart CC, Requirements for Group 1 Wastewater Streams
- 40 CFR 61 Subpart FF, 61.342(e)(2) Uncontrolled aqueous waste streams

D. S-41 – WEMCO Hydrocleaner complies with the following Regulations

Regulation 8, Rule 8 WASTEWATER COLLECTION AND SEPARATION SYSTEMS

The source is exempt from the requirements for air flotation devices due to its size.

Condition 1240

- Part I.14 Facility Limits
- Part I.18 Cumulative Increase Monitoring
- Part I.18a NMHC and NO_x estimates
- Part I.18e Estimates of NMHC emissions from wastewater sources
- Part I.18j Summary of emissions estimates and reports of non-compliance
- Parts II.92, II.92a Specific requirements for S41

BAAQMD State Implementation Plan
Regulation 8, Rule 8

The benzene waste stream managed in this source also complies with the following federal regulations:

- 40 CFR 63 Subpart CC, Requirements for Group 1 Wastewater
- 40 CFR 61 Subpart FF, 61.342(e)(2) Uncontrolled aqueous waste streams

E. S-66 Oil Water Separator complies with the following Regulations:

Regulation 8, Rule 8 WASTEWATER COLLECTION AND SEPARATION SYSTEMS

- 8-8-301.2 Wastewater separators \geq 200 gallons/day and $<$ 300 gallons/minute; organic compound vapor recovery system with efficiency \geq 95%

Condition 1240

- Part I.14 Facility Limits
- Part I.18 Cumulative Increase Monitoring
- Part I.18a NMHC and NO_x estimates
- Part I.18e Estimates of NMHC emissions from wastewater sources
- Part I.18j Summary of emissions estimates and reports of non-compliance
- Parts II.83, II.85, II.87, II.88 Specific requirements for S66
- NOTE: Parts II.84 and II.86 are removed by A31/S24 A/N 19384/19635

BAAQMD State Implementation Plan
Regulation 8, Rule 8

The benzene waste stream managed in these sources also complies with the following federal regulations:

- 40 CFR 63 Subpart CC, Requirements for Group 1 Wastewater Streams
- 40 CFR 61 Subpart FF, 61.342(e)(2) Uncontrolled aqueous waste streams

F. A-31 and S-24 comply with the following District Rules and Regulations:

Regulation 1, GENERAL PROVISIONS

- 1-107 Combination of Emissions
- 1-523 Parametric Monitoring and Recordkeeping Procedures

Regulation 6, Rule 1 PARTICULATE MATTER, GENERAL PROVISIONS

- 6-1-301 Ringelmann No. 1 Limitation
- 6-1-305 Visible Particles
- 6-1-310 Particulate Weight Limitation

Regulation 8, Rule 5 STORAGE OF ORGANIC LIQUIDS

- 8-5-118 Limited exemption, gas tight requirement
- 8-5-306 Requirements for Approved Emission Control Systems

Regulation 8, Rule 6 ORGANIC LIQUID BULK TERMINALS AND BULK PLANTS

- 8-6-301 Bulk terminal limitations

Regulation 8, Rule 8 WASTEWATER COLLECTION AND SEPARATION SYSTEMS

- 8-8-301 Wastewater separators ≥ 200 gallons/day and < 300 gallons/minute
- 8-8-301.1 Wastewater separators ≥ 200 gallons/day and < 300 gallons/minute; organic compound vapor recovery system with efficiency $\geq 95\%$
- 8-8-305.2 Oil water separator and air flotation unit slop oil vessels; organic compound vapor recovery system with efficiency $\geq 95\%$

Regulation 8, Rule 18 EQUIPMENT LEAKS

Regulation 9, Rule 10 (S-24 only)

- 9-10-111 Limited exemption – small units
- 9-10-306 Small unit requirements
- 9-10-402 Control plan requirements, small units
- 9-10-504 Records
- 9-10-505 Reports
- 9-10-605 Tune-up Procedures

Regulation 10 INCORPORATION OF NSPS BY REFERENCE

- 10-17 NSPS Subpart Kb
- 10-51 NSPS Subpart UU

Condition 1240

- Parts I.5, 6, 14, 18, 18a, 18g, 18i, 18j

Parts II.32a, 32b, 32c, 43, 55, 56, 57, 58b, 58c, 58d, 66, 69, 70, 85
[S24 only]: Part V.1

BAAQMD State Implementation Plan

Regulation 1
Regulation 6
Regulation 8, Rule 5
Regulation 8, Rule 8
Regulation 9, Rule 10

NSPS 40 CFR 60 Subpart A General Provisions

NSPS 40 CFR 60 Subpart Kb Standards of Performance for Storage Vessels for Petroleum Liquids Constructed, Reconstructed, Modified After July 23, 1984

NSPS 40 CFR 60 Subpart UU Standards of Performance for Asphalt Processing and Asphalt Roofing Manufacture

This project is considered to be ministerial under the District's CEQA Regulation 2-1-311 and therefore is not subject to CEQA review. The engineering review for this project requires only the application of standard permit conditions and standard emission factors in accordance with Permit Handbook Chapter 3.1, 3.4, and 4.0, and therefore is not discretionary as defined by CEQA.

This project is over 1,000 ft from the nearest public school and is therefore not subject to the public notification requirements of Regulation 2-1-412.

BACT, offsets, and PSD are not triggered.

VIII. CONDITIONS

Permit condition #1240 for the Valero Benicia Asphalt Plant, amended by Application # 19384 and #19631, Plant #A0901.

For All Sources

Permit Conditions II. 1, 11, 12, and 13; and IV. 1, 2, and 3 were modified or added as part of App. No. 14513.

Pursuant to permit application #17515, permit condition I.8 was modified, conditions I.9 and I.10 were added, and what had been conditions I.9 and I.10 were renumbered as I.11 and I.12, respectively.

Pursuant to permit application #17687 the total asphalt plant wide heat input has been corrected from 42 to 66.17 MMBTU/HR, S13 and S59 were permitted, and S12 was exempted from permitting.

Pursuant to permit application #1261 (May, 2000) the total asphalt plant-wide heat input has been corrected from 76.06 to 86.6 MMBTU/HR, and the allowable heat input for S19 was increased from 22.4 to 33 MMBtu/hr.

Pursuant to permit application #1819 (October, 2000), the crude oil throughput to the crude unit, S18, was raised to 5,292,000 barrels/yr.

Pursuant to permit application #7123 (March, 2003) the total asphalt plant-wide heat input has been corrected from 86.6 to 93.6 MMBTU/HR, and the allowable heat input for S19 was increased from 33 to 40 MMBtu/hr.

Pursuant to permit application #19384 (February, 2009), All sources that are abated by A-31 or S-24 can now also be contained in the closed vent system when the blower is not operating until the pressure of the system reaches 0.5 ounces (0.87 inches of water column). The P/V valves on all sources abated by A-31 or S-24 shall not exceed 500 ppmv of total organic compounds while the blower is not operating.

Pursuant to permit application #19631 (February, 2009), S-25 is removed. S-12, S-26 and S-28 are exempt per Regulation 2-1-123.2. S-9 and its drain system, pipelines are the only controlled sources must be managed in accordance with the Benzene Waste Operations NESHAP - 40 CFR 61 Subpart FF, Part 61.342(e)(1). The benzene waste streams flow to S-66 and S-41 are uncontrolled sources that must be managed in accordance with 40 CFR 61.342(e)(2).

I. ASPHALT PLANT CONDITIONS

S18 Crude Unit with Vacuum Distillation Column vented to and abated by S19 Vacuum H-1

18e. The permit holder shall estimate NMHC emissions from the following wastewater sources using the most recent version of EPA's "Water" program: S27, S41, S66, S67. The permit holder may use maximum potential to emit in place of measured throughput.

II. TANKAGE AND LOADING RACK CONDITIONS:

10. Deleted. [Basis: S25 has been permanently removed from service].

58b. The Owner/Operator shall install and properly maintain continuous temperature monitoring and recording devices for A31 (H-4607), Thermal Oxidizer and S24 (H-4603), Hot Oil Heater. The Owner/Operator shall operate A-31 with a minimum combustion zone temperature of 1400F to maintain a 98.5% destruction efficiency, whenever emissions are vented to it by one or more operational vapor recovery blowers in organic vapor service. The Owner/Operator shall operate S-24 at a minimum operating temperature of 1115F to maintain a 98.5% destruction efficiency whenever emissions are vented to it by one or more operational vapor recovery blowers in organic vapor service. (Source Test Requirements demonstrating compliance with the 98.5% abatement destruction efficiency and the Regulation 6-1-310 grain loading requirements were completed February 28 and 29, 2004.) (Applications 12704 for A-31 and Application 12236 for S-24 have been submitted for the Title V permit revisions)) (Application 19631 (2009) removed 40 CFR 61 Subpart FF citations from basis. Facility has no sources controlled by A31 or S24 for compliance with 40

CFR 61 Subpart FF.) (Basis: 40 CFR 60.113b(c)(1)(ii) and 60.113b(c)(2); 40 CFR 60.473c; Regulation 2-6-409.2.2, 2-6-414)

X. RECOMMENDATION

Issue a conditional change to the Permit to Operate to Valero Refining Company for the following equipment:

S-9 Naphtha Tank, TK-4607
S-24 Hot Oil Heater (H-4603)
S-27 Recovered Oil Tank, TK-4612A
S-41 WEMCO Hydrocleaner
S-66 Oil-Water Separator
S-67 Recovered Oil Tank, TK-4612B
A-31 Thermal Oxidizer (H-4607)

XI. EXEMPTION

Issue exemptions to Valero Refining Company for the following equipment:

S-12 Effluent Wastewater Tank (TK-4606)
S-26 Effluent Wastewater Tank (TK-4613)
S-28 Effluent Wastewater Tank (TK-4611B)

The water stored in these tanks contains less than 1% hydrocarbon and the tanks are therefore exempt from permitting in accordance with Regulation 2-1-123.2.

XII. REMOVED SOURCE

Archive the following source.

S-25 Effluent Wastewater Tank, TK-4611A

Thu H. Bui
Senior Air Quality Engineer
Engineering Division
Date:

**EVALUATION REPORT
VALERO BENICIA ASPHALT PLANT**

Application #21641 - Plant #13193

**3001 Park Road
Benicia, CA 94510**

I. BACKGROUND

Valero has submitted this application for a Permit to Operate for the following equipment:

A-17 Asphalt Loading Rack Incinerator (H46100), McGill Inc., 2.9 MMBtu/hr, abates S-17 Asphalt Truck Loading Rack

and archive the following sources:

A-4 Thermal Oxidizer (H4606), McGill Inc., 6.5 MMBtu/hr, abates S-17 Asphalt Truck Loading Rack , S-14 Naphtha Truck loading Rack and S-15 Gas Oil Truck Loading Rack

S-14 Naphtha Truck Loading Rack

S-15 Gas Oil Truck Loading Rack

While planning for the new blowdown line that connects the BAP Crude Unit (S-18) to Valero Refinery's blowdown system (S-9), Valero discovered that A-4 Thermal Oxidizer (H4606) is connected to A-17 Incinerator (H46100), which has not been permitted but had been in operation prior to 1972. A-17 will be permitted separately as an existing grandfathered source because it may have been combined as part of A-4 and it is the actual abatement device that is used to abate S-17 Asphalt Truck Loading Rack all this times. It is unknown why A-17 is not permitted as a separate source. In order to correct this oversight, the unpermitted equipment will be given a source number and A-4 will be shut down at this time to save energy. A-4 will continue to serve as the emission stack for A-17 as it has always been in the past. This oversight was not seen as a problem during annual inspection visits by the District but will be corrected in this application.

In May 2004, a source test was conducted on A-17 under normal plant operations to demonstrate compliance with the minimum destruction efficiency of 98.5%, set forth in Condition 1240.II.68 of the BAP Title V permit. The source test result showed 99.3% destruction efficiency with an average temperature of 1570°F. Based on this review, the temperature of Condition 1240.II.19 will be revised from 1400°F to 1570°F to match with the source test result. The source test was actually performed at A-17, not at A-4 in 2004. See the attached test result.

II. EMISSION CALCULATIONS

A-17 is expected to perform the same level as before; therefore, this application will not result in an emissions increase.

III. PLANT CUMULATIVE INCREASE SINCE 4/5/1991

There are no net changes to the plant cumulative emissions, because there is no emission increase from existing levels with this application.

IV. TOXIC SCREENING ANALYSIS

This application will not result in an increase in toxic air contaminant emissions from existing levels. Therefore, a Toxic RSA is not required per Regulation 2-5.

V. BEST AVAILABLE CONTROL TECHNOLOGY

This application will not result in any emission increase from existing levels. Therefore, BACT is not triggered per Regulation 2-2-301.

VI. OFFSETS

This application does not result in emission increases. Therefore, emission offsets are not needed per Regulation 2-2-302.

VII. STATEMENT OF COMPLIANCE

The Asphalt Loading Rack S-17 at the asphalt plant will continue to be exempt from Regulation 8-6-110 - Exemption, Low Vapor Pressure Organic Liquids for loading low vapor pressure materials that are less than or equal 0.5 psia.

The Asphalt Loading Rack S-17 is subject to and expected to be in compliance with Regulation 8-15 Organic Compounds, Emulsified and Liquid Asphalts.

Source S-17 is subject to and expected to comply with the requirement of Regulation 6, Rule 1 – Particulate Matter and Visible Emissions. Visible particulate emissions are limited by section 6-1-301 which prohibits visible emissions greater than or equal to Ringelmann No. 1 for no more than 3 minutes in an hour.

This application is considered to be ministerial under the District's CEQA Regulation 2-1-311 and therefore is not subject to CEQA review. The engineering review for this project requires only the application of standard permit conditions and standard emission factors in accordance with Permit Handbook Chapter 3.1 for Bulk Loading Facilities.

This project is over 1,000 ft from the nearest public school and is therefore not subject to the public notification requirements of Regulation 2-1-412.

Offsets, NSPS, NESHAP and PSD are not applicable.

VIII. CONDITIONS

Permit condition #1240 for the Valero Benicia Asphalt Plant.

For All Sources

Permit Conditions II. 1, 11, 12, and 13; and IV. 1, 2, and 3 were modified or added as part of App. No. 14513.

Pursuant to permit application #17515, permit condition I.8 was modified, conditions I.9 and I.10 were added, and what had been conditions I.9 and I.10 were renumbered as I.11 and I.12, respectively.

Pursuant to permit application #17687 the total asphalt plant wide heat input has been corrected from 42 to 66.17 MMBTU/HR, S13 and S59 were permitted, and S12 was exempted from permitting.

Pursuant to permit application #1261 (May, 2000) the total asphalt plant-wide heat input has been corrected from 76.06 to 86.6 MMBTU/HR, and the allowable heat input for S19 was increased from 22.4 to 33 MMbtu/hr.

Pursuant to permit application #1819 (October, 2000), the crude oil throughput to the crude unit, S18, was raised to 5,292,000 barrels/yr.

Pursuant to permit application #7123 (March, 2003) the total asphalt plant-wide heat input has been corrected from 86.6 to 93.6 MMBTU/HR, and the allowable heat input for S19 was increased from 33 to 40 MMBtu/hr.

Pursuant to permit application #19384 (February, 2009), All sources that are abated by A31 or S24 can now also be contained in the closed vent system when the blower is not operating until the pressure of the system reaches 0.5 ounces (0.87 inches of water column). The P/V valves on all sources abated by A31 or S24 shall not exceed 500 ppmv of total organic compounds while the blower is not operating.

Pursuant to permit application # 19193 (February, 2009), process offgas from S-18 Crude Unit routed from the S19 Vacuum Heater to the refinery fuel gas recovery system, S9, Facility B2626.

Pursuant to permit application #21641 (March, 2010), A17 (H46100) is separated from A4 (H4606). A17 will continue to abate S17 Asphalt Truck Loading Rack. A4 will be shut down and serve as an emission stack downstream of A17.

I. ASPHALT PLANT CONDITIONS

S18 Crude Unit, amended by Application 19193

1. The total throughput of feed oil to S18 Crude Unit shall not exceed 5,292,000 barrels in any consecutive 12-month period. (cumulative increase, toxics, offsets)
2. The total throughput of feed oil to S18 Crude Unit shall not exceed 18,000 barrels in any calendar day. (cumulative increase, toxics)
3. The owner/operator of S-18 Crude Unit shall vent its emissions to the refinery fuel gas recovery system S-9 at all times. (cumulative increase, toxics)
4. Each day, the permittee shall record, by material name, in a District approved log, the total volume of each and every liquid material throughput to S18 during the preceding calendar day, in gallon units or barrel units. At the conclusion of each month, the permittee shall total the daily log records and record the sum as

the monthly throughput of all liquid materials to S18, in a District approved log. Additionally, the permittee shall record in the District approved log the throughput of all liquid materials to S18 for each rolling 12 consecutive month period. This log shall be retained for at least 5 years from date of entry, shall be kept on site, and shall be made available to the District staff on request. (cumulative increase)

5. The maximum heat input to all asphalt plant combustion units except S68, Emergency Diesel-Powered Firewater Pump, shall not exceed a total of 93.6 MM BTU/Hr. Compliance will be determined from the daily reading of the PG&E natural gas flow meter. These meter readings shall be logged and initialed by the operations coordinator on a daily basis. These readings and the monthly PG&E bills shall be made available to the District upon request. (cumulative increase)

5a. The owner/operator of S19 shall only use natural gas and the maximum heat input to S19, Vacuum Heater, shall not exceed 40 MMbtu/hr. (cumulative increase)

5b. CO emissions in the exhaust of S19, Vacuum Heater, shall not exceed 50 ppmdv at 3% oxygen over any one-hour period. (cumulative increase, BACT)

5c. CO emissions in the exhaust of S19, Vacuum Heater, shall not exceed 1.47 lb/hr over any one-hour period. (cumulative increase, BACT)

6. Fuel oil and/or diesel fuel shall not be combusted in the asphalt plant's heaters or boilers or other combustion sources except for S68, Emergency Diesel-powered Firewater Pump and S71, Emergency Diesel-powered Air Compressor. (cumulative increase) (modified 8/12/99, 4/24/02, 4/19/06)

7. Mechanical seals will be installed on all new rotary pumps and compressors. Mechanical packing of best available design will be installed in new reciprocating pumps. All compressor seals will be vented to an operating firebox or the vapors will otherwise be eliminated by a method, which is satisfactory to the District. (cumulative increase)

8. Vacuum Heater (S19) shall be equipped with a John Zink LoNOx Burner. Average NOx emissions from S19 shall not exceed 25 ppm corrected to 3% oxygen on a dry basis (one hour averaging period). (cumulative increase, BACT)

9. Deleted 06/02/98.

10. Boilers S20 and S21 and heater S19 shall be equipped with individual continuous recording oxygen analyzers. (2-1-403)

11. Contingent on EPA's approval of 40 CFR 60, Subpart Ja – Standards of Performance for Petroleum Refineries, the owner/operator shall submit a permit application the District for NOx and flaring applicability and revise the Title V permit if necessary. (Regulation 2-1-403)

12. Deleted (vacuum exhaust routed from S19, Vacuum Heater to refinery fuel gas recovery system, S9, Facility B2626)

13. Deleted (vacuum exhaust routed from S19, Vacuum Heater to refinery fuel gas recovery system, S9, Facility B2626)

14. Total asphalt plant emissions shall not exceed the limits listed below:

- | | |
|--|----------------|
| a. Non-Methane Hydrocarbons..... | 42.705 tons/yr |
| b. Sulfur Dioxide, SO ₂ | 28.049 tons/yr |
| c. Nitrogen Oxides, as NO ₂ | 40.047 tons/yr |
- (Cumulative Increase)

15. Asphalt plant wastewater and refinery wastewater shall not be used for dust control at this facility. (Cumulative Increase)

16a. Deleted. 3/2010. Redundant with Condition 21233, part 7.

16b. Deleted (basis: requirement no longer applicable since exhaust from S18 Crude Unit routed from the S19, Vacuum Heater to the refinery fuel gas recovery system, S9, Facility B2626)

17. A/C source test condition, deleted.

18. To assure compliance with part I.14 of Condition 1240, the permit holder shall perform the following monitoring on a semi-annual basis, starting on January 1 of each year.

18a. The permit holder shall estimate emissions of Non-methane hydrocarbons (NMHC) and nitrogen oxides for each quarter.

18b. The permit holder shall estimate fugitive NMHC emissions from valves, flanges, pumps, and compressors using the draft "California Implementation Guidelines for Estimating Mass Emissions of Fugitive Hydrocarbon Leaks at Petroleum Facilities" dated February 1999, or later version.

18c. The permit holder shall estimate tank NMHC emissions from the following tanks using the most recent version of EPA's "Tanks" program or EPA publication AP-42: S3, S5-S9, S13, S37, S38, S51-S53, S59-S63, S65, S70.

18d. The permit holder shall estimate NMHC emissions from the following loading racks using EPA publication AP-42: S15, S16, S17, S31, S54.

18e. The permit holder shall estimate NMHC emissions from the following wastewater sources using the most recent version of EPA's "Water" program: S27, S41, S66, S67. The permit holder may use maximum potential to emit in place of measured throughput.

18f. The permit holder shall estimate NMHC emissions from the following combustion sources: S19-S21. The permit holder shall use fuel measurements for each fuel, the F-factor method in EPA Method 19, and the average concentration in the last source test for these estimates.

18g. The permit holder shall estimate NMHC emissions from the following combustion sources: S24, S34, A4A17, A31. The permit holder shall use the maximum capacity as an estimate of the fuel usage, and the appropriate emission factor from EPA publication AP-42. The permit holder shall estimate NMHC emissions from S68 and S71. The permit holder shall use the maximum capacity as an estimate of the fuel usage, the actual hours of operation, and the appropriate emission factor from EPA publication AP-42.

18h. The permit holder shall estimate emissions of nitrogen oxides (NO_x) from the following combustion sources: S19-S21. The permit holder shall use fuel measurements for each fuel, the F-factor method in EPA Method 19, and the average concentration in the last source test for these estimates.

18i. The permit holder shall estimate emissions of nitrogen oxides (NO_x) from the following combustion sources: S24, S34, A4A17, A31. The permit holder shall use the maximum capacity as an estimate of the fuel usage, and the appropriate emission factor from EPA publication AP-42. The permit holder shall estimate NO_x emissions from S68 and S71. The permit holder shall use the maximum capacity as an estimate of the fuel usage, the actual hours of operation, and the appropriate emission factor from EPA publication AP-42.

18j. Within 30 days after the end of each semi-annual period, the permit holder shall calculate the emission estimates required by parts I.18b through 18i for the quarter, summarize the emission estimates for the period, and for the previous period. If the emission estimates exceed the limits in part I.14 of Condition 1240, the permit holder shall report non-compliance with part I.14 of this condition in accordance with Standard Condition I.F of the Title V permit. The emissions estimates shall be kept on-site for a minimum of five years and be made available to District staff upon request. (Cumulative Increase)

19. Within 90 days of issuance of the Title V permit, the The Owner/Operator shall install continuous temperature monitoring and recording device for A4A17, Thermal OxidizerIncinerator. The Owner/Operator shall operate A4 A17, Thermal Oxidizer Incinerator at a minimum temperature of 1400F1570F. The District may adjust this minimum temperature, if source test data demonstrates that an alternate temperature is necessary for or capable of maintaining compliance with Part II.68. (Source Test requirement completed May 20, 2004 and minimum operating temperature added per Application 11815.) (2-6-503)

19a. The temperature limit in part I.19 shall not apply during an “Allowable Temperature Excursion”, provided that the temperature controller setpoint complies with the temperature limit. An Allowable Temperature Excursion is one of the following:

- a. A temperature excursion not exceeding 20 degrees F; or
- b. A temperature excursion for a period or periods which when combined are less than or equal to 15 minutes in any hour; or
- c. A temperature excursion for a period or periods which when combined are more than 15 minutes in any hour, provided that all three of the following criteria are met.
 - i. the excursion does not exceed 50 degrees F;
 - ii. the duration of the excursion does not exceed 24 hours; and
 - iii. the total number of such excursions does not exceed 12 per calendar year (or any consecutive 12 month period).

Two or more excursions greater than 15 minutes in duration occurring during the same 24-hour period shall be counted as one excursion toward the 12 excursion limit. (basis: Regulation 2-1-403)

19b. For each Allowable Temperature Excursion that exceeds 20 degrees F. and 15 minutes in duration, the Permit Holder shall keep sufficient records to demonstrate that they meet the

qualifying criteria described above. Records shall be retained for a minimum of five years from the date of entry, and shall be made available to the District upon request. Records shall include at least the following information:

- a. Temperature controller setpoint;
- b. Starting date and time, and duration of each Allowable Temperature Excursion;
- c. Measured temperature during each Allowable Temperature Excursion;
- d. Number of Allowable Temperature Excursions per month, and total number for the current calendar year; and
- e. All strip charts or other temperature records.
(basis: Regulation 2-1-403)

19c. For the purposes of parts I.19a and I.19b, a temperature excursion refers only to temperatures below the limit. (basis: Regulation 2-1-403)

19d. The owner/operator shall conduct District approved source tests at A-17 to determine initial compliance with the limits in parts II.68. The owner/operator shall submit the source test results to the District staff no later than 60 days after the source test. (basis: Cumulative Increase)

19e. The owner/operator shall obtain approval for all source test procedures from the District's Source Test Section prior to conducting any tests. The owner/operator shall comply with all applicable testing requirements as specified in Volume V of the District's Manual of Procedures. The owner/operator shall notify the District's Source Test Section, in writing, of the source test protocols and projected test dates at least 7 days prior to testing. (basis: RACT, Cumulative Increase)

20. Deleted Application 9297

II. TANKAGE AND LOADING RACK CONDITIONS:

1. Deleted in Revision 2. Ownership of S2 transferred to Facility B5574 by Application No. 7980/8915.
2. Deleted 5/01. Redundant with condition 1240 II.26.
3. Deleted 07/20/99. Redundant with condition 1240 II.27.
4. Deleted 07/20/99. Redundant with condition 1240 II.54.
5. Deleted 07/20/99. Redundant with condition 1240 II.60.
6. Deleted (basis: requirement no longer applicable since exhaust from S18 Crude Unit routed from the S19, Vacuum Heater to the refinery fuel gas recovery system, S9, Facility B2626)
7. Deleted 07/20/99. Redundant with condition 1240 II.51.
8. The owner/operator shall abate emissions from Source S-17 with Abatement device A-17, Incinerator during all periods of loading operation. Asphalt loading at S17 shall be immediately terminated if the blowdown system is venting to the thermal oxidizer (A4). (Cumulative Increase)

9. Deleted 08/12/99.

10. Delete. (Source S25 is permanently removed from service)

S1 Crude Oil Storage Tank 1A, External Floating Roof,
Capacity: 3,419,000 Gallons

S2 Crude Oil Storage Tank, External Floating TK-1B,
Capacity: 3,419,000 Gallons

S4 Crude Oil Storage Tank, External Floating Roof,
TK-10A, Capacity: 1,382,000 Gallons

S23 Crude Oil Storage Tank, External Floating Roof,
TK-10B, Capacity: 1,382,000 Gallons

Conditions 11-24 Deleted in Revision 2. Ownership of S1, S2, S4, and S23 transferred to Facility B5574 by Application No. 7980/8915.

S9 Internal Floating Roof Tank, TK-7; Capacity: 571,200 Gallons, White, Storing: Naphtha equipped with a mechanical shoe primary seal, rim mounted secondary seal, and welded deck

25. Material other than Naphtha may be throughput to or stored in S9, if all of the following are satisfied:

- a. the storage of each material complies with all other conditions applicable to this source
- b. the storage of each material complies with all other applicable regulatory requirements
- c. the permittee keeps District approved records that demonstrate to the District's satisfaction that no toxin listed in Table 2-5-1 is emitted from S9 in an amount in excess of the toxin's respective trigger level set forth in Table 2-1-5. (cumulative increase, toxics)

27. The true vapor pressure of each and all material stored in S9 shall not exceed 11 psia. (cumulative increase, toxics)

27a. S9 shall not be operated unless it is equipped with a District approved internal floating roof with a mechanical shoe primary seal, a rim mounted secondary seal, and a welded deck. (cumulative increase, NSPS)

28. The total throughput of all liquid materials to S9 shall not exceed 24,019,000 gallons (571,880 barrels) in any rolling 12 consecutive month period. (cumulative increase, toxics)

29. On a monthly basis, the permittee shall record in a District approved log the total volume of each and all liquid materials throughput to S9 each month and each rolling 12 consecutive month period, in gallon units or barrel units. This log shall be retained for at least 5 years from date of entry, shall be kept on site, and shall be made available to the District staff on request. (cumulative increase)

S13 Fixed Roof Storage Tank (TK-8); Capacity: 88,000 Gallons, Storing: Kerosene, Light or Heavy Vacuum Gas Oil, and Asphalt abated by (either) A3 or

A20 Mist Eliminator F-10 or F-500 and A31 Thermal Oxidizer H-4607. If A31 and the vapor recovery blower are inoperative, S13 emissions shall be contained in a District approved closed vent system as specified in Parts 93 and 96. Alternately, S13 emissions shall be vented to source S24, Hot Oil Heater (H-4603), as a backup until A31 is operating. (cumulative increase)

S59 Fixed Roof Storage Tank (TK-5); Capacity: 1,050,000 Gallons, Storing: Kerosene, Light or Heavy Vacuum Gas Oil and Asphalt, abated by A1 or A3 Mist Eliminator F-8 (or) F-10 and A31 Thermal Oxidizer H-4607. If A31 and the vapor recovery blower are inoperative, S59 emissions shall be contained in a District approved closed vent system as specified in Parts 93 and 96. Alternately, S59 emissions shall be vented to source S24, Hot Oil Heater (H-4603), as a backup until A31 is operating. (cumulative increase)

S63 Kerosene/Light Vacuum Gas Oil/Heavy Vacuum Gas Oil/Asphalt Storage Tank, Fixed Roof, TK-31, Capacity: 1,218,000 Gallons abated by A3 or A20 Mist Eliminator F-10 or F-500 and A31 Thermal Oxidizer H-4607. If A31 and the vapor recovery blower are inoperative, S63 emissions shall be contained in a District approved closed vent system as specified in Parts 94 and 96. Alternately, S63 emissions shall be vented to source S24, Hot Oil Heater (H-4603), as a backup until A31 is operating. (cumulative increase)

30. Petroleum materials other than Kerosene, Light or Heavy Vacuum Gas Oil, and Asphalt may be stored in S13, S59, and S63 if all of the following are satisfied:

- a. the storage of each petroleum material complies with all other conditions applicable to S13, S59, or S63.
- b. the storage of each petroleum material complies with all other applicable regulatory requirements
- c. the permittee keeps District approved records which demonstrate to the District's satisfaction that no toxin listed in Table 2-1-5 is emitted from S13, S59, or S63 in an amount in excess of the toxin's respective trigger level set forth in Table 2-1-5.

(cumulative increase, toxics)

31. The true vapor pressure of each material stored in S13, S59, or S63 shall not exceed 1.5 psia. (cumulative increase, toxics)

31a. To assure compliance with the limit in part II.31, the permit holder shall take a sample from each tank on an annual basis and determine the true vapor pressure of the sample. Records of these analyses shall be retained for at least 5 years from the date of the analysis, shall be kept on site, and shall be made available to the District staff on request. (cumulative increase, toxics)

32a. The owner/operator shall maintain and operate A31 Thermal Oxidizer H-4607 and S24 Hot Oil Heater H-4603; with an overall collection and destruction efficiency of at least 98.5%, by weight whenever petroleum and VOC materials are stored and/or transferred at S3, S5, S6, S7, S8, S13, S25, S31, S37, S38, S41, S51, S52, S53, S54, S59, S60, S61, S62, S63, S65, S66 and S70. (Regulation 8-5-306, NSPS, cumulative increase, BACT, toxics)

32b. Deleted. Combined with Part 32a.

32c. Deleted. Combined with Part 32a.

32d. Deleted. Redundant with Regulation 8-18.

32e. To monitor compliance with the standard in 40 CFR 60.112b(a)(3)(i) for fugitive emissions at closed vent systems, the owner/operator shall inspect the closed vent systems that control S13, S59, and S63 using EPA Method 21 on a semi-annual basis. (Regulation 2-6-503)

33a. The total combined throughput of all materials to S13, S59, and S63 shall not exceed 68,208,000 gallons (1,624,600 barrels) in any rolling 12 consecutive month period. (cumulative increase, toxics)

33b. Cutback asphalt materials including but not limited to SC Cutback Asphalt, MC Cutback Asphalt, and FM-1 Cutback Asphalt and other cutback asphalt materials shall NOT be stored in or transferred to S63. (toxics)

34. On a monthly basis, the permittee shall record in a District approved log the total volume of each liquid material throughput to S13, S59, or S63 by material name (e.g., kerosene, light vacuum gas oil, heavy vacuum gas oil, asphalt) each month and each rolling 12 consecutive month period, in gallon units or barrel units. This log shall be retained for at least 5 years from date of entry, shall be kept on site, and shall be made available to the District staff on request. (cumulative increase)

40. Deleted May, 2001

41. Deleted May, 2001

42. Deleted May, 2001

43. Deleted May, 2001

44. Deleted May, 2001

S3 Fixed Roof Storage Tank, TK-1C, Storing: Heavy Vacuum Gas Oil, Capacity: 3,415,000 Gallons operated with a District approved vapor recovery system and abated by (either) A3 or A20 Mist Eliminator F-10 or F-500 and A31 Thermal Oxidizer H-7. If A31 and the vapor recovery blower are inoperative, S3 emissions shall be contained in a District approved closed vent system as specified in Parts 94 and 96. Alternately, S3 emissions shall be vented to source S24, Hot Oil Heater (H-4603), as a backup until A31 is operating. (cumulative increase)

40. Materials other than Heavy Gas Oil may be stored in S3, if all of the following are satisfied:

- a. the storage of each petroleum material complies with all other conditions applicable to S3
- b. the storage of each petroleum material complies with all other applicable regulatory requirements
- c. the permittee keeps District approved records that demonstrate to the District's satisfaction that no toxin listed in Table 2-5-1 is emitted from S3 in an amount in excess of the toxin's respective trigger level set forth in Table 2-5-1. (cumulative increase, toxics)

41. The permittee shall ensure that at least 38,300,000 gallons (the 1996 calendar year baseline throughput to S3) of gas oil is throughput exclusively to S3 for storage during every rolling 12 consecutive month period, prior to transferring/storing gas oil material into another vessel for which VOC emissions are not abated with a destruction efficiency of at least 98.5%, by weight. (offsets)

42. The true vapor pressure of each and all material stored in S3 shall not exceed 0.5 psia. (cumulative increase, NSPS)

43. Deleted. Combined with Part 32a.

44. Deleted. Redundant with Regulation 8-18.

45. All tank fittings present at S3 shall be gasketed. (BACT)

46. At the conclusion of each month, the permittee shall record in a District approved log the total volume of each and all liquid materials throughput to S3 during that month and for each rolling 12 consecutive month period, in gallon units or barrel units. This log shall be retained for at least 5 years from date of entry, shall be kept on site, and shall be made available to the District staff on request. (cumulative increase)

47. Deleted 11/29/99. Start-up condition

S5 Asphalt Storage Tank, Fixed Roof, TK-2A, Capacity: 3,415,000 Gallons abated by either A1 or A3 Mist Eliminator F-8 or F-10 and A31 Thermal Oxidizer H-4607. If A31 and the vapor recovery blower are inoperative, S5 emissions shall be contained in a District approved closed vent system as specified in Parts 93 and 96. Alternately, S5 emissions shall be vented to source S24, Hot Oil Heater (H-4603), as a backup until A31 is operating. (cumulative increase)

S6 Asphalt Storage Tank, Fixed Roof, TK-2B, Capacity: 3,415,000 Gallons abated by either A1 or A3 Mist Eliminator F-8 or F-10 and A31 Thermal Oxidizer H-4607. If A31 and the vapor recovery blower are inoperative, S6 emissions shall be contained in a District approved closed vent system as specified in Parts 93 and 96. Alternately, S6 emissions shall be vented to source S24, Hot Oil Heater (H-4603), as a backup until A31 is operating. (cumulative increase)

S7 Asphalt Storage Tank, Fixed Roof, TK-3, Capacity:

1,050,000 Gallons abated by either A1 or A3 Mist Eliminator F-8 or F-10 and A31 Thermal Oxidizer H-4607. If A31 and the vapor recovery blower are inoperative, S7 emissions shall be contained in a District approved closed vent system as specified in Parts 93 and 96. Alternately, S7 emissions shall be vented to source S24, Hot Oil Heater (H-4603), as a backup until A31 is operating. (cumulative increase)

S8 Asphalt Storage Tank, Fixed Roof, TK-4, Capacity: 1,050,000 Gallons abated by either A1 or A3 Mist Eliminator F-8 or F-10 and A31 Thermal Oxidizer H-4607. If A31 and the vapor recovery blower are inoperative, S8 emissions shall be contained in a District approved closed vent system as specified in Parts 93 and 96. Alternately, S8 emissions shall be vented to source S24, Hot Oil Heater (H-4603), as a backup until A31 is operating. (cumulative increase)

S37 Asphalt Storage Tank, Fixed Roof, TK 54, Capacity: 100,000 Gallons abated by A3 or A20 Mist Eliminator F-10 or F-500 and A31 Thermal Oxidizer H-4607. If A31 and the vapor recovery blower are inoperative, S37 emissions shall be contained in a District approved closed vent system as specified in Parts 94 and 96. Alternately, S37 emissions shall be vented to source S24, Hot Oil Heater (H-4603), as a backup until A31 is operating. (cumulative increase)

S38 Asphalt Storage Tank, Fixed Roof, TK-55, Capacity: 100,000 Gallons abated by A3 or A20 Mist Eliminator F-10 or F-500 and A31 Thermal Oxidizer H-4607. If A31 and the vapor recovery blower are inoperative, S38 emissions shall be contained in a District approved closed vent system as specified in Parts 94 and 96. Alternately, S38 emissions shall be vented to source S24, Hot Oil Heater (H-4603), as a backup until A31 is operating. (cumulative increase)

S51 Asphalt Storage Tank TK-506; Fixed Roof Tank, Capacity: 152,880 Gallons abated by A3 or A20 Mist Eliminator F-10 or F-500 and A31 Thermal Oxidizer H-4607. If A31 and the vapor recovery blower are inoperative, S51 emissions shall be contained in a District approved closed vent system as specified in Parts 94 and 96. Alternately, S51 emissions shall be vented to source S24, Hot Oil Heater (H-4603), as a backup until A31 is operating. (cumulative increase)

S52 Asphalt Storage Tank TK 507, Fixed Roof Tank, Capacity: 152,880 Gallons abated by A3 or A20 Mist Eliminator F-10 or F-500 and A31 Thermal Oxidizer H-4607. If A31 and the vapor recovery blower are inoperative, S52 emissions shall be contained in a District approved closed vent system as specified in Parts 94 and 96. Alternately, S52 emissions shall be vented to source S24, Hot Oil Heater (H-4603), as a backup until A31 is operating. (cumulative increase)

S53 Asphalt Storage Tank TK 508, Fixed Roof Tank, Capacity: 152,880 Gallons abated by A3 or A20 Mist Eliminator F-10 or F-500 and A31 Thermal Oxidizer H-4607. If A31 and the vapor recovery blower are inoperative, S53 emissions shall be contained in a District approved closed vent system as specified in Parts

94 and 96. Alternately, S53 emissions shall be vented to source S24, Hot Oil Heater (H-4603), as a backup until A31 is operating. (cumulative increase)

S60 Asphalt Storage Tank TK-505; Fixed Roof, Capacity: 15,000 Gallons abated by (either) A3 or A20 Mist Eliminator F-10 or F-500 and A31 Thermal Oxidizer H-4607. If A31 and the vapor recovery blower are inoperative, S60 emissions shall be contained in a District approved closed vent system as specified in Parts 94 and 96. Alternately, S60 emissions shall be vented to source S24, Hot Oil Heater (H-4603), as a backup until A31 is operating. (cumulative increase)

S61 Asphalt Storage Tank, Fixed Roof, TK-30A, Capacity: 995,400 Gallons abated by A3 or A20 Mist Eliminator F-10 or F-500 and A31 Thermal Oxidizer H-4607. If A31 and the vapor recovery blower are inoperative, S61 emissions shall be contained in a District approved closed vent system as specified in Parts 94 and 96. Alternately, S61 emissions shall be vented to source S24, Hot Oil Heater (H-4603), as a backup until A31 is operating. (cumulative increase)

S62 Asphalt Storage Tank, Fixed Roof, TK-30B, Capacity: 995,400 Gallons abated by A3 or A20 Mist Eliminator F-10 or F-500 and A31 Thermal Oxidizer H-4607. If A31 and the vapor recovery blower are inoperative, S62 emissions shall be contained in a District approved closed vent system as specified in Parts 94 and 96. Alternately, S62 emissions shall be vented to source S24, Hot Oil Heater (H-4603), as a backup until A31 is operating. (cumulative increase)

S65 Asphalt Storage Tank, Fixed Roof, TK-32 Tank Capacity: 6,920,000 Gallons abated by A3 or A20 Mist Eliminator F-10 or F-500 and A31 Thermal Oxidizer H-4607. If A31 and the vapor recovery blower are inoperative, S65 emissions shall be contained in a District approved closed vent system as specified in Parts 94 and 96. Alternately, S65 emissions shall be vented to source S24, Hot Oil Heater (H-4603), as a backup until A31 is operating. (cumulative increase)

S70 Asphalt Additive Mixing Tank, Fixed Roof, Tank Capacity: 2,200 Gallons abated by A3 or A20 Mist Eliminator F-10 or F-500 and A31 Thermal Oxidizer H-4607. If A31 and the vapor recovery blower are inoperative, S70 emissions shall be contained in a District approved closed vent system as specified in Parts 94 and 96. Alternately, S70 emissions shall be vented to source S24, Hot Oil Heater (H-4603), as a backup until A31 is operating. (cumulative increase)

48. The sum total asphalt throughput to S5, S6, S7, S8, S37, S38, S51, S52, S53, S60, S61, S62, and S65 shall not exceed 6,738,349 barrels (283,010,658 gallons) in any 12 consecutive month period. (cumulative increase, offsets)

49. For S5, S6, S7, S8, S37, S38, S51, S52, S53, S60, S61, S62, S65, S70: Cutback asphalt materials including but not limited to SC Cutback Asphalt, MC Cutback Asphalt, and FM-1 Cutback Asphalt and other cutback asphalt materials shall not be stored in or transferred to any of the above tanks. (toxics)

50. For S5, S6, S7, S8, S37, S38, S51, S52, S53, S60, and S70: the true vapor pressure of each and all materials stored in each tank shall not exceed 0.5 psia. (cumulative increase, offsets)
51. For S61 and S62, the true vapor pressure of each and all materials stored in each tank shall not exceed 0.49 psia. (cumulative increase, offsets, BACT)
52. For S65, the true vapor pressure of each and all materials stored in S65 shall not exceed 0.49 psia. (cumulative increase, offsets, BACT)
53. Deleted. Redundant with Regulation 8-18.
54. Deleted May, 2001.
55. Deleted. Combined with Part 32a
56. Deleted. Combined with Part 32a
57. Deleted. Combined with Part 32a
58. Separately, for each of S5, S6, S7, S8, S37, S38, S51, S52, S53, S60, S61, S62 S65, and S70, at the conclusion of each month, the permittee shall record, by material name, in a District approved log, the total volume of each liquid material throughput to each tank during that month and during each rolling 12 consecutive month period, in gallon units or barrel units. This log shall be retained for at least 5 years from date of entry, shall be kept on site, and shall be made available to the District staff on request. (cumulative increase)
- 58a. Deleted Application 17468.
- 58b. The Owner/Operator shall install and properly maintain continuous temperature monitoring and recording devices for A31, Thermal Oxidizer (H-4607) and S24, Hot Oil Heater (H-4603). The Owner/Operator shall operate A-31 with a minimum combustion zone temperature of 1400F to maintain a 98.5% destruction efficiency, whenever emissions are vented to it by one or more operational vapor recovery blowers in organic vapor service. The Owner/Operator shall operate S-24 at a minimum operating temperature of 1115F to maintain a 98.5% destruction efficiency, whenever emissions are vented to it by one or more vapor recovery blowers in organic vapor service. (Source Test Requirements demonstrating compliance with the 98.5% abatement destruction efficiency and the Regulation 6-310 grain loading requirements were completed February 28 and 29, 2004.) (Applications 12704 for A-31 and Application 12236 for S-24 have been submitted for the Title V permit revisions) (Basis: 40 CFR 60.113b(c)(1)(ii) and 60.113b(c)(2); 40 CFR 60.473c; 40 CFR 61.354(c)(1); 40 CFR 61.354(c)(4), Regulation 2-6-409.2.2, 2-6-414)
- 58c. The temperature limit in Part II.58b for A-31 shall not apply during an “Allowable Temperature Excursion”, provided that the temperature controller set

point remains at a minimum of 1,400°F. An Allowable Temperature Excursion is one of the following:

- a. A temperature excursion not exceeding 20°F; or
- b. A temperature excursion for a period or periods which when combined are less than or equal to 15 minutes in any hour; or
- c. A temperature excursion for a period or periods which when combined are more than 15 minutes in any hour, provided that all three of the following criteria are met.
 - i. the excursion does not exceed 50°F;
 - ii. the duration of the excursion does not exceed 24 hours; and
 - iii. the total number of such excursions does not exceed 12 per calendar year (or any consecutive 12 month period).

Two or more excursions greater than 15 minutes in duration occurring during the same 24-hour period shall be counted as one excursion toward the 12 excursion limit. (basis: Regulation 2-1-403)

58d. For each Allowable Temperature Excursion that exceeds 20°F. and 15 minutes in duration, the Permit Holder shall keep sufficient records to demonstrate that they meet the qualifying criteria described above. Records shall be retained for a minimum of five years from the date of entry, and shall be made available to the District upon request. Records shall include at least the following information:

- a. Temperature controller setpoint;
- b. Starting date and time, and duration of each Allowable Temperature Excursion;
- c. Measured temperature during each Allowable Temperature Excursion;
- d. Number of Allowable Temperature Excursions per month, and total number for the current calendar year; and
- e. All strip charts or other temperature records.

58e. For the purposes of parts II.58c and II.58d, a temperature excursion refers only to temperatures below the limit. (basis: Regulation 2-1-403)

58f. For the purposes of parts II.58c and II.58d, a temperature excursion occurs only when one or more vapor recovery system blowers is operating in organic vapor service, and is vented to A-31. When a blower is used to start up A-31, the blower is in "fresh air" service and not in organic vapor service, until A-31 meets the minimum operating temperature and is acceptable to receive organic vapors. (basis: Regulation 2-1-403)

59. Deleted (S14 is no longer in service)

60. Deleted (S14 is no longer in service)

61. Deleted (S14 is no longer in service)

S15. Deleted (S15 is no longer in service, the gas oil stream is routed to the Refinery for further processing)Kerosene and Light Vacuum Gas Oil Loading Rack abated by A4 Thermal Oxidizer H-6

62. Deleted (S15 is no longer in service, the gas oil stream is routed to the Refinery for further processing) S15 shall be operated with a submerged fill pipe and be abated by A4 Thermal Oxidizer H-6 at all times that materials are transferred at S15.

(cumulative increase, offsets, BACT, toxics)

62a. To monitor compliance with the standard in BAAQMD Regulation 8-6-306 for vapor tightness of equipment associated with organic liquid delivery and loading operations at S15, the owner/operator shall inspect the equipment using EPA Method 21 on a quarterly basis. (Regulation 2-6-503)

62b. To monitor compliance with the standard in BAAQMD Regulation 8-6-306 for leak-free equipment associated with organic liquid delivery and loading operations at S15, the owner/operator shall inspect the equipment on a quarterly basis. (Regulation 2-6-503)

63. Deleted (S15 is no longer in service, the gas oil stream is routed to the Refinery for further processing) emissions shall be captured by a District approved vapor recovery system and shall be abated by A4 Thermal Oxidizer H-6 with a destruction efficiency of at least 98.5%, by weight, as measured across A4.

(cumulative increase, offsets, BACT, toxics)

64a. Deleted (S15 is no longer in service, the gas oil stream is routed to the Refinery for further processing) The true vapor pressure of the materials transferred at and/or sampled from S15 shall not exceed 1.5 psia. All materials loaded at S15 must be transferred from Tanks S13, S59, or S63. (cumulative increase, offsets, toxics)

64b. The total combined throughput of Kerosene and Light Vacuum Gas Oil to S15, shall not exceed 283,011,000 gallons (1,483,000 barrels) during any consecutive 12-months. (cumulative increase, offsets, toxics)

S17 Asphalt Loading Racks abated by A2 Mist Eliminator F-9 and A4 A17 Thermal Oxidizer/Incinerator H-46100

S31 Rail Car Loading Rack; 5 Loading Arms, Loading: Asphalt and Light Vacuum Gas Oil abated by A6 Mist Eliminator F-3 and A31 Thermal Oxidizer H-4607. If A31 and the vapor recovery blower are inoperative, S31 emissions shall be contained in a District approved closed vent system as specified in Parts 94 and 96. Alternately, S31 emissions shall be vented to source S24, Hot Oil Heater (H-4603), as a backup until A31 is operating. (cumulative increase)

S54 Asphalt Loading Rack abated by (either) A3 or A20 Mist Eliminator F-10 or F-500 and A31 Thermal Oxidizer H-4607. If A31 and the vapor recovery blower are inoperative, S54 emissions shall be contained in a District approved closed vent system as specified in Parts 94 and 96. Alternately, S54 emissions shall be vented to source S24, Hot Oil Heater (H-4603), as a backup until A31 is operating. (cumulative increase)

65. S17 shall be abated by A2 Mist Eliminator F-9 and A4 A17 Thermal Oxidizer/Incinerator H-46100 at all times that materials are transferred at S17. (cumulative increase)
66. [Deleted. Combined with Part 64b]
67. [Deleted. Combined with part 64b]
68. Emissions from S17 shall be captured by a District approved vapor recovery system and shall be abated by A2 Mist Eliminator F-9 and A4 A17 Thermal Oxidizer/Incinerator H-46100 with a destruction efficiency of at least 98.5%, by weight, as measured across A4A17. (cumulative increase, BACT)
69. Deleted Combined with Part 32a.
70. Deleted. Combined with Part 32a.
71. The true vapor pressure of the materials transferred at or sampled from S17 and/or S 54 shall not exceed 0.5 psia except for 5,500 Barrels per year of kerosene when required to produce medium-cure cutback asphalt products. (cumulative increase, offsets)
72. The true vapor pressure of the materials transferred at or sampled from S31 shall not exceed 1.5 psia, unless the material contains asphalt. (cumulative increase, toxics, offsets)
- 72a. To monitor compliance with the standard in BAAQMD Regulation 8-6-306 for vapor tightness of equipment associated with organic liquid delivery and loading operations at S31, the owner/operator shall inspect the equipment using EPA Method 21 on a quarterly basis. (Regulation 2-6-503)
- 72b. To monitor compliance with the standard in BAAQMD Regulation 8-6-306 for leak-free equipment associated with organic liquid delivery and loading operations at S31, the owner/operator shall inspect the equipment on a quarterly basis. (Regulation 2-6-503)
73. If asphalt or any asphalt containing material or any material blended with asphalt is transferred at or sampled from S31, the true vapor of the material may not exceed 0.5 psia. (cumulative increase, toxics, offsets)
74. The total combined throughput of asphalt and all asphalt containing materials to S17, S31, and S54 shall not exceed 283,011,000 gallons during any consecutive 12-months. (cumulative increase, offsets)
75. The permittee shall maintain a District approved log of the monthly throughput of asphalt and all asphalt containing materials to S17, S31, and S54 in gallon units or barrel units during each month and during each rolling 12 consecutive month period, in gallon units or barrel units. This log shall be

retained for at least 5 years from date of entry, shall be kept on site, and shall be made available to the District staff on request. (cumulative increase)

76. Deleted May, 2001.

77. Deleted May, 2001.

78. Deleted May, 2001.

79. Deleted May, 2001.

80. Deleted May, 2001.

81. Deleted May, 2001.

82. Deleted May, 2001.

S66 Oil Water Separator, Physical Capacity: 830 GPM, Permitted Capacity: 210 GPM abated by (either) A1 or A3 Mist Eliminator F-8 or F-10 and A31 Thermal Oxidizer H-4607. If A31 and the vapor recovery blower are inoperative, S66 emissions shall be contained in a District approved closed vent system as specified in Parts 93 and 96. Alternately, S66 emissions shall be vented to source S24, Hot Oil Heater (H-4603), as a backup until A31 is operating. (cumulative increase)

83. The permittee shall ensure that the throughput of liquid material to S66 shall not exceed 110,376,000 gallons per year (210 gallons per minute). (basis: cumulative increase)

84. The cover and each access opening at S66 shall be equipped with a gasketed, vapor tight cover (as defined in Regulation 8, Rule 8). Each cover and access opening shall be kept closed and sealed except when the opening is being used for inspection, maintenance, or wastewater sampling. (basis: Reg. 8, Rule 8)

85. Deleted. Combined with Part 32a.

86. Deleted. Redundant with Regulation 8-18.

87. Not less frequently than on a monthly basis, the permittee shall measure and record the volume (in gallons) of oil (slop oil) product recovered at S66 and not less frequently than on a monthly basis, the permittee shall measure and record the volume (in gallons) of waste water product recovered at S66 (waste water discharge to City of Benicia). The sum of the volume of slop oil product and the volume of wastewater product shall recorded in a District approved log as the throughput of liquid material to S66. (basis: cumulative increase)

88. On a monthly basis, the permittee shall record in a District approved log the total volume of all liquid materials throughput to S66 each month, in gallon units or barrel units. This log shall be retained for at least 5 years from date of entry,

shall be kept on site, and shall be made available to the District staff on request.
(basis: cumulative increase)

89. Deleted 2001.

S16 Truck Loading Rack-Heavy Vacuum Gas Oil

90. The true vapor pressure of the materials transferred at and/or sampled from S16 shall not exceed 0.49 psia. (cumulative increase)

91. The total throughput of materials transferred through S16 shall not exceed 25,749,000 gallons (613,000 barrels) during any consecutive 12-months.
(cumulative increase)

91a. The permittee shall maintain a District approved log of the monthly throughput of materials transferred at S16 in gallon units or barrel units during each month and during each rolling 12 consecutive month period, in gallon units or barrel units. This log shall be retained for at least 5 years from date of entry, shall be kept on site, and shall be made available to the District staff on request.
(cumulative increase)

S41, Wemco Hydrocleaner Induced Air Flotation Machine, abated by A1 or A3 Mist Eliminator F-8 or F-10 and S24 Hot Oil Furnace H-3 or A31 Thermal Oxidizer.

92. The permittee shall ensure that the throughput of liquid material to S41 shall not exceed 77,263,200 gallons per year (147 gallons per minute). (basis: cumulative increase)

92a. The permittee shall maintain a District approved log of the monthly throughput of liquid material transferred to S41 in gallon units during each month and during each rolling 12 consecutive month period. This log shall be retained for at least 5 years from date of entry, shall be kept on site, and shall be made available to the District staff on request. (cumulative increase)

93. The following sources, which shall be operated with a District approved closed vent system, are connected to vapor recovery collection header #1 and vapor recovery blower B-4608 or spare blower B-46501: S5, S6, S7, S8, S25, S41, S59, and S66. Emissions are contained in the closed vent collection header whenever a blower is not operating, as long as no P/V valve in the header is lifting. The pressure of each of the three headers at a representative location shall be monitored at least once every 8 hours, whenever the vapor recovery blower is not operating. If the manometer pressure of any header exceeds 0.5 ounces (0.87 inches of water column), A-31 or S-24 shall be restarted and emissions conveyed to it by the blower. (basis: cumulative increase)

94. The following sources, which shall be operated with a District approved closed vent system, are connected to vapor recovery collection header #2 and vapor recovery blower B-46500 or spare blower B-46501: S3, S13, S37, S38,

S51, S52, S53, S54, S60, S61, S62, S63, S65, and S70. Emissions are contained in the closed vent collection header whenever a blower is not operating, as long as no P/V valve in the header is lifting. The pressure of the each of the three headers at a representative location shall be monitored at least once every 8 hours, whenever the vapor recovery blower is not operating. If the manometer pressure of any header exceeds 0.5 ounces (0.87 inches of water column), A-31 or S-24 shall be restarted and emissions conveyed to it by the blower. (basis: cumulative increase)

96. To determine compliance with Parts 93 and 94, the owner/operator shall maintain the following records and provide all of the data necessary to evaluate compliance with the above parts, including the following information:
- a. All manometer pressures of each of the three headers abated by A-31 or S-24
 - b. Date and time when the blower is down and which abating equipment (A-31, closed vent system or S-24) is in operation
 - c. Reason why the blower is down

All records shall be retained on-site for at least five years, from the date of entry, and made available for inspection by District staff upon request. These recordkeeping requirements shall not replace the recordkeeping requirements contained in any applicable District Regulations. (basis: cumulative Increase)

96. The owner/operator of S3, S5, S6, S7, S8, S12, S13, S25, S26, S27, S28, S31, S37, S38, S-39, S40, S41, S51, S52, S53, S54, S59, S60, S61, S62, S63, S65, S66, S67 and S70 shall not use any P/V valve that leaks total organic compounds in excess of 500 ppmv when the vapor recovery blower is not operating. Any exceedance of this limit will result in a violation, except for P/V valve that is subject to Regulation 8-18 and is already on the non-repairable list. (basis: to allow the use of closed vent system in lieu of A-31 or S-24)

III. MARINE OPERATIONS CONDITIONS-S30, Part 1 through 9, deleted because S30 was not in service since April 5, 2005
(Cumulative Increase)

IV. ODOR REDUCTION MEASURES (Added per AN 14513, 9/95)

- *1. The permit holder will maintain water seals, P-traps, caps, covers or equivalent on all process water drains. (1-301)
- *2. The permit holder will implement an Asphalt Tank Truck Dome Inspection Program for all asphalt tank trucks that they load. If a truck enters the facility with a leaking or malfunctioning dome lid, the permit holder will take the following action.
 - *a. First occurrence in rolling twelve month period: the permit holder will orally notify the truck driver and dispatcher of the faulty dome lid, and request that the lid be repaired prior to the truck re-entering the facility.
 - *b. Second occurrence in a rolling twelve month period: the permit holder will notify the driver and the trucking company in writing that if the truck enters the

facility again with a malfunctioning dome hatch, the permit holder will not load the truck until the hatch has been repaired.

*c. Third occurrence in a rolling twelve-month period: the permit holder will not load the truck. The permit holder will also notify the driver and dispatcher, verbally and in writing, that the truck will not be loaded until the hatch has been repaired, and the repair has been inspected or repair documentation has been received by the permit holder to ensure that the hatch is in proper working order.

*The permit holder shall keep records of all inspections and notifications. These records shall be made available to the District upon request.
(1-301)

*3. The permit holder shall provide written notification of the Asphalt Tank Truck Dome Inspection Program to any additional trucking company that may do business with the permit holder in the future, within two weeks of the first asphalt receipt. (1-301)

V. OTHER SOURCES

S24 Hot Oil Heater H-4603; Max Firing Rate 9 MM BTU/hr

1. Respective emissions of nitrogen oxides, and carbon monoxide (CO) from S24 shall not exceed 30 ppm and 50 ppm at 3% O₂. (Cumulative Increase)

IX. RECOMMENDATION

Issue a conditional change to the Permit to Operate to Valero Refining Company for the following equipment:

A-17 Asphalt Loading Rack Incinerator (H46100), McGill Inc., 2.9 MMBtu/hr, abates S-17 Asphalt Truck Loading Rack

and archive the following sources:

A-4 Thermal Oxidizer (H4606), McGill Inc., 6.5 MMBtu/hr, abates S-17 Asphalt Truck Loading Rack, S-14 Naphtha Truck loading Rack and S-15 Gas Oil Truck Loading Rack

S-14 Naphtha Truck Loading Rack

S-15 Gas Oil Truck Loading Rack

*Thu H. Bui
Senior Air Quality Engineer
Engineering Division*

Permit Evaluation and Statement of Basis: Site A0901, Valero Benicia Asphalt Plant, 3001 Park Road, Benicia, CA 94510

Date:

THB:T\ValeroAsphalt\21641e

APPENDIX B

Compliance Assurance Monitoring Analysis

Permit Evaluation and Statement of Basis: Site A0901, Valero Benicia Asphalt Plant, 3001 Park Road, Benicia, CA 94510

Source #	Source Description	Title V Permit Applicability (Current/Future)	Pollutant	Federally Enforceable Emissions Limit or Standard?		Basis of Limit Proposed > 11/15/90?	Uses a Control Device for Compliance?	Pre-Control PTE > MST?	Continuous Compliance Determination Method in Title V Permit?	Subject to CAM?
				40 CFR 64.2(a)(1)						
				Emission Limit	Basis	40 CFR 64.2(b)(1)(i)	40 CFR 64.2(a)(2)	40 CFR 64.2(a)(3)	40 CFR 64.2(b)(1)(vi)	
3	Gas Oil Storage Tank, TK-4601C	Current/Future	VOC	98.5% destruction of vapors whenever petroleum and VOC materials stored	Condition 1240, part II.32a	No	A31, Thermal Oxidizer or S24, Process Heater	No (Note 1, 2)	Temperature Monitoring	No - Pre-Control PTE < MST
			Opacity	Ringelmann No. 1 for no more than 3 minutes/hour	SIP 6-301				Temperature Monitoring	
			PM	0.15 gr/dscf	SIP 6-310				Temperature Monitoring	
5	Asphalt Storage Tank, TK-4602A	Current/Future	VOC	98.5% destruction of vapors whenever petroleum and VOC materials stored	Condition 1240, part II.32a	No	A31, Thermal Oxidizer or S24, Process Heater	No (Note 1, 2)	Temperature Monitoring	No - Pre-Control PTE < MST
			Opacity	Ringelmann No. 1 for no more than 3 minutes/hour	SIP 6-301				Temperature Monitoring	
			PM	0.15 gr/dscf	SIP 6-310				Temperature Monitoring	
6	Asphalt Storage Tank, TK-4602B	Current/Future	VOC	98.5% destruction of vapors whenever petroleum and VOC materials stored	Condition 1240, part II.32a	No	A31, Thermal Oxidizer or S24, Process Heater	Not necessary to evaluate [exempt per 40 CFR 64.2(b)(1)(vi)]	Temperature Monitoring	No - Pre-Control PTE < MST
			Opacity	Ringelmann No. 1 for no more than 3 minutes/hour	SIP 6-301				Temperature Monitoring	
			PM	0.15 gr/dscf	SIP 6-310				Temperature Monitoring	
7	Asphalt Storage Tank, TK-4603	Current/Future	VOC	98.5% destruction of vapors whenever petroleum and VOC materials stored	Condition 1240, part II.32a	No	A31, Thermal Oxidizer or S24, Process Heater	Not necessary to evaluate [exempt per 40 CFR 64.2(b)(1)(vi)]	Temperature Monitoring	No - Pre-Control PTE < MST
			Opacity	Ringelmann No. 1 for no more than 3 minutes/hour	SIP 6-301				Temperature Monitoring	
			PM	0.15 gr/dscf	SIP 6-310				Temperature Monitoring	
8	Asphalt Storage Tank, TK-4604	Current/Future	VOC	98.5% destruction of vapors whenever petroleum and VOC materials stored	Condition 1240, part II.32a	No	A31, Thermal Oxidizer or S24, Process Heater	Not necessary to evaluate [exempt per 40 CFR 64.2(b)(1)(vi)]	Temperature Monitoring	No - Pre-Control PTE < MST
9	Naphtha Storage Tank, TK-4607	Current/Future	NA	NA	NA	NA	None	NA	NA	No - Pre-Control PTE < MST
				Control device standards; 95% control of organic vapors	SIP 8-5-306				Temperature Monitoring	
				Control device standards; 95% control of inlet VOC	60.112b(a)(3)(ii)				Temperature Monitoring	
13	Kerosene Tank, TK-4608	Current/Future	VOC	98.5% destruction of vapors whenever petroleum and VOC materials stored	Condition 1240, part II.32a	No	A31, Thermal Oxidizer or S24, Process Heater	Not necessary to evaluate [exempt per 40 CFR 64.2(b)(1)(vi)]	Temperature Monitoring	No - Pre-Control PTE < MST
				21 g/cubic meter (0.17 lb/1000 gallons)	BAAQMD 8-6-301, BAAQMD 8-6-304				Temperature Monitoring	
15	Truck Loading Racks - Gas Oil	Current/Future	VOC	98.5% destruction of vapors whenever petroleum and VOC materials stored	Condition 1240, part II.32a	No	A4, Thermal Oxidizer	Not necessary to evaluate [exempt per 40 CFR 64.2(b)(1)(vi)]	Temperature Monitoring	No - Pre-Control PTE < MST
16	Truck Loading Racks - Heavy Vacuum Gas Oil	Current/Future	NA	NA	NA	NA	None	NA	NA	No - Pre-Control PTE < MST
			VOC	98.5% destruction of vapors by weight	Condition 1240, part II.68				Temperature Monitoring	
			Opacity	Ringelmann No. 1 for no more than 3 minutes in any hour	SIP 6-301				Temperature Monitoring	
17	Truck Loading Racks - Asphalt	Current/Future	PM	0.15 gr/dscf	SIP 6-310	No	A4, Thermal Oxidizer	Not necessary to evaluate [exempt per 40 CFR 64.2(b)(1)(vi)]	Temperature Monitoring	No - Pre-Control PTE < MST
18	Crude Unit including atmospheric tower, vacuum tower, and KD stripper tower	Current	HAP	Reduce HAPs by 98% or to 20 ppm @ 3% oxygen	40 CFR 63.643(a)(2)	Yes - 40 CFR 63 Subpart CC proposed 8/18/1995	A4, Thermal Oxidizer, A44, Off Gas Caustic Scrubber, S19, Vacuum Heater	Not necessary to evaluate [exempt per 40 CFR 64.2(b)(1)(i)]	Exempt from monitoring per 63.644(a)(3)	No - Pre-Control PTE < MST
18	Crude Unit including atmospheric tower, vacuum tower, and KD stripper tower	Future	HAP	No - Emissions routed to fuel gas system are exempt from monitoring	40 CFR 63.640(d)(5)	NA	No - vented to B2626 Refinery Fuel Gas System (S-9) [NOTE 1]	NA	NA	No - Pre-Control PTE < MST
				Fuel gas H2S concentration limited to 162 ppmv, dry, prior to mixing averaged over any consecutive 3-hr period	Condition 1240, part I.11.a				Fuel Gas H2S CEM	

Permit Evaluation and Statement of Basis: Site A0901, Valero Benicia Asphalt Plant, 3001 Park Road, Benicia, CA 94510

Source #	Source Description	Title V Permit Applicability (Current/Future)	Pollutant	Federally Enforceable Emissions Limit or Standard?		Basis of Limit Proposed > 11/15/90?	Uses a Control Device for Compliance?	Pre-Control PTE > MST?	Continuous Compliance Determination Method in Title V Permit?	Subject to CAM?
				40 CFR 64.2(a)(1)						
				Emission Limit	Basis	40 CFR 64.2(b)(1)(i)	40 CFR 64.2(a)(2)	40 CFR 64.2(a)(3)	40 CFR 64.2(b)(1)(vi)	
19	Vacuum Heater (natural gas and/or asphalt plant refinery fuel gas), F-4601	Current/Future	NA	Fuel gas H2S concentration limited to 10 ppmv, dry, prior to mixing averaged over any consecutive 24-hr period	Condition 1240, part I.12	NA	None	NA	Fuel Gas H2S CEM	No - Pre-Control PTE < MST
20	Steam Boiler H-4602A (natural gas)	Current/Future	NA	NA	NA	NA	None	NA	NA	No - Pre-Control PTE < MST
21	Steam Boiler H-4602B (natural gas)	Current/Future	NA	NA	NA	NA	None	NA	NA	No - Pre-Control PTE < MST
24	Hot Oil Heater, H-4603 (natural gas)	Current/Future	VOC	95% control of organic vapors (from S13, S59, S63)	SIP 8-5-306	NA	None	NA	Temperature Monitoring	No - Pre-Control PTE < MST
				21 g/cubic meter (0.17 lb/1000 gallons)	BAAQMD 8-6-301				Temperature Monitoring	
				95% combined collection and destruction efficiency (S66)	SIP 8-8-301.3				Temperature Monitoring	
				70% combined collection and destruction efficiency (S27, S67)	SIP 8-8-305.2				Temperature Monitoring	
				95% control of organic vapors (from S13, S59, S63)	40 CFR 60.112b(a)(3)(ii)				Temperature Monitoring	
98.5% destruction of vapors by weight whenever petroleum and VOC materials are stored or transferred	Condition 1240, part II.32a	NA	None	NA	Temperature Monitoring					
27	Recovered Oil Tank, TK-4612A	Current/Future	VOC	Combined collector/destruction efficiency of 70% by weight	SIP 8-8-305.2	No	A31, Thermal Oxidizer or S24, Process Heater	Not necessary to evaluate [exempt per 40 CFR 64.2(b)(1)(vi)]	Temperature Monitoring	No - Pre-Control PTE < MST
31	Rail Car Asphalt and Gas Oil Loading Rack, five Spots	Current/Future	VOC	0.17 pounds per 1,000 gallons loaded	BAAQMD 8-6-301	No	A31, Thermal Oxidizer or S24, Process Heater	Not necessary to evaluate [exempt per 40 CFR 64.2(b)(1)(vi)]	Temperature Monitoring	No - Pre-Control PTE < MST
				98.5% control efficiency when S31 whenever petroleum and VOC materials are transferred	Condition 1240, part II.32a				Temperature Monitoring	
				Opacity PM	Ringelmann No. 1 for no more than 3 minutes in any hour 0.15 gr/dscf				SIP 6-301 SIP 6-310	
34	Tank Heater, H-4605 (natural gas)	Current/Future	NA	NA	NA	NA	None	NA	NA	No - Pre-Control PTE < MST
37	Rubberized Asphalt Sales Tank, TK-4654	Current/Future	VOC	Ringelmann No. 1 for no more than 3 minutes/hour	SIP 6-301	No	A31, Thermal Oxidizer or S24, Process Heater	Not necessary to evaluate [exempt per 40 CFR 64.2(b)(1)(vi)]	Temperature Monitoring	No - Pre-Control PTE < MST
				0.15 gr/dscf	SIP 6-310				Temperature Monitoring	
38	Rubberized Asphalt Sales Tank, TK-4656	Current/Future	VOC	98.5% destruction of vapors whenever petroleum and VOC materials stored	Condition 1240, part II.32a	No	A31, Thermal Oxidizer or S24, Process Heater	Not necessary to evaluate [exempt per 40 CFR 64.2(b)(1)(vi)]	Temperature Monitoring	No - Pre-Control PTE < MST
				0.15 gr/dscf	SIP 6-301 SIP 6-310				Temperature Monitoring	
41	WEMCO Hydrocleaner – Induced Air Flotation Separator	Current/Future	VOC	98.5% destruction of vapors by weight whenever petroleum and VOC materials are stored or transferred	Condition 1240, part II.32a	No	A31, Thermal Oxidizer or S24, Process Heater	Not necessary to evaluate [exempt per 40 CFR 64.2(b)(1)(vi)]	Temperature Monitoring	No - Pre-Control PTE < MST
51	Sales Tank – Asphalt Liquid, TK-46506	Current/Future/Future	VOC	Ringelmann No. 1 for no more than 3 minutes/hour	SIP 6-301	No	A31, Thermal Oxidizer or S24, Process Heater	Not necessary to evaluate [exempt per 40 CFR 64.2(b)(1)(vi)]	Temperature Monitoring	No - Pre-Control PTE < MST
				0.15 gr/dscf	SIP 6-310				Temperature Monitoring	
			Opacity PM	Ringelmann No. 1 for no more than 3 minutes/hour	SIP 6-301				Temperature Monitoring	
				0.15 gr/dscf	SIP 6-310				Temperature Monitoring	

Permit Evaluation and Statement of Basis: Site A0901, Valero Benicia Asphalt Plant, 3001 Park Road, Benicia, CA 94510

Source #	Source Description	Title V Permit Applicability (Current/Future)	Pollutant	Federally Enforceable Emissions Limit or Standard?		Basis of Limit Proposed > 11/15/90?	Uses a Control Device for Compliance?	Pre-Control PTE > MST?	Continuous Compliance Determination Method in Title V Permit?	Subject to CAM?
				40 CFR 64.2(a)(1)						
				Emission Limit	Basis	40 CFR 64.2(b)(1)(i)	40 CFR 64.2(a)(2)	40 CFR 64.2(a)(3)	40 CFR 64.2(b)(1)(vi)	
52	Sales Tank – Asphalt Liquid, TK-46507	Current/Future	VOC	98.5% destruction of vapors whenever petroleum and VOC materials stored	Condition 1240, part II.32a	No	A31, Thermal Oxidizer or S24, Process Heater	Not necessary to evaluate [exempt per 40 CFR 64.2(b)(1)(vi)]	Temperature Monitoring	No - Pre-Control PTE < MST
53	Sales Tank – Asphalt Liquid, TK-46508	Current/Future	Opacity	Ringelmann No. 1 for no more than 3 minutes/hour	SIP 6-301	No	A31, Thermal Oxidizer or S24, Process Heater	Not necessary to evaluate [exempt per 40 CFR 64.2(b)(1)(vi)]	Temperature Monitoring	No - Pre-Control PTE < MST
			PM	0.15 gr/dscf	SIP 6-310				Temperature Monitoring	
54	Asphalt Loading Rack	Current/Future	VOC	98.5% destruction of vapors by weight whenever petroleum and VOC materials are stored or transferred	Condition 1240, part II.32a	No	A31, Thermal Oxidizer or S24, Process Heater	Not necessary to evaluate [exempt per 40 CFR 64.2(b)(1)(vi)]	Temperature Monitoring	No - Pre-Control PTE < MST
			Opacity	Ringelmann No. 1 for no more than 3 minutes in any hour	SIP 6-301				Temperature Monitoring	
59	Gas Oil Fixed Roof Storage Tank, TK-4605, OOS	Current/Future	VOC	Control device standards: 95% control of organic vapors	SIP 8-5-306	No	A31, Thermal Oxidizer or S24, Process Heater	Not necessary to evaluate [exempt per 40 CFR 64.2(b)(1)(vi)]	Temperature Monitoring	No - Pre-Control PTE < MST
			VOC	Control device standards: 95% control of inlet VOC	60.112b(a)(3)(ii)				Temperature Monitoring	
60	Asphalt Tank, TK-46505	Current/Future	VOC	98.5% destruction of vapors whenever petroleum and VOC materials stored	Condition 1240, part II.32a	No	A31, Thermal Oxidizer or S24, Process Heater	Not necessary to evaluate [exempt per 40 CFR 64.2(b)(1)(vi)]	Temperature Monitoring	No - Pre-Control PTE < MST
			Opacity	Ringelmann No. 1 for no more than 3 minutes/hour	SIP 6-301				Temperature Monitoring	
61	Asphalt Tank, TK-4630A	Current/Future	PM	0.15 gr/dscf	SIP 6-310	No	A31, Thermal Oxidizer or S24, Process Heater	Not necessary to evaluate [exempt per 40 CFR 64.2(b)(1)(vi)]	Temperature Monitoring	No - Pre-Control PTE < MST
			VOC	98.5% destruction of vapors whenever petroleum and VOC materials stored	Condition 1240, part II.32a				Temperature Monitoring	
62	Asphalt Tank, TK-4630B	Current/Future	PM	0.15 gr/dscf	SIP 6-310	No	A31, Thermal Oxidizer or S24, Process Heater	Not necessary to evaluate [exempt per 40 CFR 64.2(b)(1)(vi)]	Temperature Monitoring	No - Pre-Control PTE < MST
			VOC	98.5% destruction of vapors whenever petroleum and VOC materials stored	Condition 1240, part II.32a				Temperature Monitoring	
63	KERO/LVGO/HVGO/Asphalt Tank, TK-4631	Current/Future	VOC	Control device standards: 95% control of organic vapors	SIP 8-5-306	No	A31, Thermal Oxidizer or S24, Process Heater	Not necessary to evaluate [exempt per 40 CFR 64.2(b)(1)(vi)]	Temperature Monitoring	No - Pre-Control PTE < MST
			VOC	Control device standards: 95% control of inlet VOC	60.112b(a)(3)(ii)				Temperature Monitoring	
65	Asphalt Tank, TK-4632	Current/Future	VOC	98.5% destruction of vapors whenever petroleum and VOC materials stored	Condition 1240, part II.32a	No	A31, Thermal Oxidizer or S24, Process Heater	Not necessary to evaluate [exempt per 40 CFR 64.2(b)(1)(vi)]	Temperature Monitoring	No - Pre-Control PTE < MST
			Opacity	Ringelmann No. 1 for no more than 3 minutes/hour	SIP 6-301				Temperature Monitoring	
66	Oil Water Separator	Current/Future	VOC	95% combined collection and destruction efficiency	SIP 8-8-301.3	No	A31, Thermal Oxidizer or S24, Process Heater	Not necessary to evaluate [exempt per 40 CFR 64.2(b)(1)(vi)]	Temperature Monitoring	No - Pre-Control PTE < MST
			VOC	98.5% control efficiency when S31 whenever petroleum and VOC materials are transferred	Condition 1240, part II.32a				Temperature Monitoring	

Permit Evaluation and Statement of Basis: Site A0901, Valero Benicia Asphalt Plant, 3001 Park Road, Benicia, CA 94510

Source #	Source Description	Title V Permit Applicability (Current/Future)	Pollutant	Federally Enforceable Emissions Limit or Standard?		Basis of Limit Proposed > 11/15/90?	Uses a Control Device for Compliance?	Pre-Control PTE > MST?	Continuous Compliance Determination Method in Title V Permit?	Subject to CAM?
				40 CFR 64.2(a)(1)						
				Emission Limit	Basis					
67	Recovered Oil Tank, TK-4612B	Current/Future	VOC	Combined collection/destruction efficiency of 70% by weight	SIP 8-8-305.2	No	A31, Thermal Oxidizer or S24, Process Heater	Not necessary to evaluate [exempt per 40 CFR 64.2(b)(1)(vi)]	Temperature Monitoring	No - Pre-Control PTE < MST
69	Asphalt Additive Loading Bin	Current/Future	NA	NA	NA	NA	None	NA	NA	No - Pre-Control PTE < MST
70	Asphalt Additive Mixing Tank, TK-46500	Current/Future	VOC	Ringelmann No. 1 for no more than 3 minutes in any hour	SIP 6-301	Not necessary to evaluate [exempt per 40 CFR 64.2(b)(1)(vi)]	A31, Thermal Oxidizer or S24, Process Heater	Not necessary to evaluate [exempt per 40 CFR 64.2(b)(1)(vi)]	Temperature Monitoring	No - Pre-Control PTE < MST
				0 percent opacity except for one consecutive 15-min period in any 24-hr period for cleaning	40 CFR 60.473(c), 60.474(c)(5), Condition 1240, part II.58b				Temperature Monitoring	
				Opacity PM	0.15 gr/dscf SIP 6-310				Temperature Monitoring	
				98.5% control efficiency when S31 whenever petroleum and VOC materials are transferred	Condition 1240, part II.32a			Temperature Monitoring		
71	Emergency Diesel Air Compressor	Current/Future	PM	50 hrs/yr operating limit, 0.15 g PM/bhp-hr	Condition 22928, part 1	Yes	A71, Catalyzed Diesel Particulate Filter	Not necessary to evaluate [exempt per 40 CFR 64.2(b)(1)(i)]	Hourly Totalizing Meter	No - Pre-Control PTE < MST
¹ Based on good engineering judgment and knowledge of actual facility emissions, it is assumed that the facility pre-control potential to emit for regulated air pollutants is less than the major source threshold. Therefore, no single source would have potential pre-control emissions above the major source definition.										
² The Valero Benicia Asphalt was formerly the Huntway Refining Facility. It was purchased by Valero Refining Company on June 1, 2001. Although the original Title V permit application submitted by Huntway indicated that the potential to emit was less than the threshold for a major facility, the Benicia Asphalt Plant was considered to be a "smaller facility" only subject to major facility review consistent with BAAQMD Regulation 2-6-312 (because it had actual emissions that exceeded the specified thresholds prior to July 24, 1995).										

Permit Evaluation and Statement of Basis: Site A0901, Valero Benicia Asphalt Plant, 3001 Park Road,
Benicia, CA 94510