

**Application for Authority to Construct
and Permit to Operate Amendment
for
MARSH LANDING
GENERATING STATION
Contra Costa County, California**

**Application #18404
Plant #19169**

Submitted to:
BAY AREA AIR QUALITY MANAGEMENT DISTRICT

September 2009

Prepared for:



MIRANTSM
MARSH LANDING, LLC

Prepared by:

URS



MARSH LANDING GENERATING
STATION PROJECT

APPLICATION #18404

PLANT # 19169

ATC/PTO AMENDMENT

Prepared For:

Bay Area Air Quality Management District

Prepared on behalf of

Mirant Marsh Landing, LLC

September 22, 2009

URS

1333 Broadway, Suite 800
Oakland, CA 94612

**ATC/PTO Application Amendment
Marsh Landing Generating Station**

Table of Contents

1.0 INTRODUCTION 1-1
 1.1 Overview..... 1-1

2.0 PROJECT DESCRIPTION 2-1
 2.1 Equipment..... 2-1

3.0 EQUIPMENT SPECIFICATIONS 3-1
 3.1 Equipment List..... 3-1

4.0 EXPECTED EMISSIONS..... 4-1
 4.1 Gas Turbine Criteria Pollutant and Hazardous Air Pollutant Emissions 4-1
 4.2 Gas-Fired Fuel Preheater Criteria Pollutant and HAP Emissions..... 4-2

5.0 LAWS, ORDINANCES, AND REGULATIONS..... 5-1

6.0 EMISSION OFFSETS..... 6-1

7.0 AMBIENT AIR QUALITY AND PSD ANALYSIS 7-1
 7.1 Air Dispersion Modeling 7-1
 7.1.1 Building Wake Effects..... 7-1
 7.1.2 Meteorological Data 7-1
 7.1.3 Receptor Locations 7-1
 7.1.4 Construction Impacts 7-1
 7.1.5 Turbine Impact Screening Modeling 7-2
 7.1.6 1-Hour Startup Scenarios..... 7-2
 7.1.7 Refined Modeling 7-3
 7.1.8 Fumigation Analysis..... 7-3
 7.2 Compliance with Ambient Air Quality Standards and PSD Requirements 7-3
 7.2.1 Normal Plant Operation..... 7-3
 7.2.2 Turbine Commissioning 7-4
 7.2.3 Impacts for Non-Attainment Pollutants and their Precursors 7-4
 7.2.4 Impacts on Air Quality Related Values in Class I Area 7-4

8.0 BACT ANALYSIS 8-1

9.0 HEALTH RISK ASSESSMENT 9-1
 9.1 Public Health Impact Assessment Approach..... 9-1
 9.2 Construction Phase Emissions 9-1
 9.3 Operational Phase Emissions..... 9-1
 9.4 Estimated Lifetime Cancer Risk 9-2
 9.5 Estimated Chronic and Acute Total Hazard Indices..... 9-3
 9.6 Criteria Pollutants 9-3

List of Appendices

Appendix A	References
Revised Appendix B	Additional Figures
Revised Appendix C	Emissions Calculations

**ATC/PTO Application Amendment
Marsh Landing Generating Station**

List of Tables

Revised Table 2-1	Heat and Material Balance Case Descriptions – Simple-Cycle Power Blocks
Revised Table 4-2	Maximum Simple Cycle Unit Operating Schedule and Stack Parameters
Revised Table 4-3	1-Hour Operating Emission Rates for Simple Cycle Units
Revised Table 4-5	Criteria Pollutant Emission Rates during Startup and Shutdown
Revised Table 4-6	Total Project Annual Emissions of Criteria Pollutants
Revised Table 4-8	HAPs Emission Rates from the Operation of Each 5000F Simple Cycle CTG
Revised Table 4-10	HAPs Emission Rates from the Operation of Each Fuel Gas Preheater
Revised Table 6-2	Estimated Emission Credit Requirement to Offset Project Emissions
Revised Table 7-5	Marsh Landing Turbine Screening Results Simple Cycle Units
Revised Table 7-6	Maximum Hourly NO ₂ and CO Emissions
Revised Table 7-8	Criteria Pollutant Sources and Emission Totals for the Worst Case Project Emissions Scenarios for All Averaging Times
Revised Table 7-9	AERMOD Modeling Results for Project Operations (All Project Sources Combined)
Revised Table 7-12	Project Commissioning Modeling Results
Revised Data Request Table 8-1	Peak Concentrations Due to Nocturnal Inversion Breakup Fumigation
Revised Data Request Table 8-2	Shoreline Inversion X/Q Values for Different Thermal Inversion Boundary Layer Factors
Revised Data Request Table 8-3	Peak Concentrations Due to Shoreline Inversion Fumigation
Revised Table 8-1	Summary of Proposed BACT
Revised Table 9-1	Toxicity Values Used To Characterize Health Risks
Revised Table 9-2	Estimated Cancer Risk and Acute and Chronic Noncancer Total Hazard Indices Due to MLGS Emissions of TACs

List of Figures

Revised Figure 1-1	Project Location Map
Revised Figure 1-2	Aerial View of Proposed Project
Revised Figure 2-1	General Plot Plan
Revised Figure 2-2	Simple Cycle Units 1 and 2 Heat and Material Balance
Revised Figure 2-3	Simple Cycle Units 3 and 4 Heat and Material Balance
Revised Figure 7-4	Locations of Maximum Predicted Ground Level Pollutant Concentrations for the Operational Project Area

ATC/PTO Application Amendment Marsh Landing Generating Station

1.0 INTRODUCTION

The purpose of this amendment is to present information that has changed as a result of project modifications to the Marsh Landing Generating Station (MLGS). The modified MLGS will still consist of four power blocks, but the power blocks will be four Siemens 5000F combustion turbine units operating in simple-cycle mode. The four Siemens combustion turbines are the same as originally proposed in previous submittals. As so modified, the MLGS will be a nominal 760-megawatt (MW) facility that is designed to provide peaking power and is expected to operate at a maximum 20 percent annual capacity factor.

The information contained in this amendment follows the structure used in the original Authority to Construct (ATC) application. When no changes were required to a section, it is explicitly noted in the text. Revised tables and figures from the original ATC or from Data Request responses are presented with the original table or figure number, but prefaced with “Revised.”

1.1 Overview

The MLGS project will be changed from two Siemens Flex Plant 10 (FP10) combined-cycle units and two Siemens 5000F combustion turbine units operating in simple-cycle mode (Simple Cycle units) to four Simple Cycle units. The Simple Cycle units will provide peaking power and are expected to operate at approximately 20 percent capacity factor, generating approximately 760 MW (net) when operated together at 75 degrees Fahrenheit (°F) temperature and 54 percent relative humidity.

The proposed modifications will align the project’s capabilities with the expected needs of the electricity system. The modified MLGS will be a peaking facility that is ideally suited to serve the needs of California’s electric system as it increasingly relies on intermittent renewable resources such as solar and wind facilities. The location and the aerial overview of the MLGS are shown on Revised Figure 1-1 and Revised Figure 1-2.

The MLGS is designed to provide the fast-start, peaking, and ramping capabilities that will be necessary to facilitate increasing reliance on renewable resources and displacement of older, less efficient conventional facilities. The four Simple Cycle turbines will be capable of fast-start operation (within about 11 minutes from cold status), and are designed to be started, ramped up and down, and shut down on an intra-day basis as needed to meet the needs of the system. With an expected maximum annual capacity factor of 20 percent, the modified MLGS is designed specifically for fast-start, backup, and peaking service and is intended to operate when electricity needs cannot be met by resources that are higher in the state’s preferred loading order.

The elimination of the combined-cycle FP10 units and the reduction in the project’s maximum annual capacity factor (i.e., to a 20 percent maximum annual capacity factor instead of the 40 to 50 annual capacity factor associated with the FP10 units), also greatly reduces the project’s total water consumption. To serve the project’s reduced need for process water, Mirant Marsh Landing proposes to use brackish groundwater to be supplied from new groundwater wells.

The change in project design also results in modifications to the general arrangement presented in previous ATC submittals. These modifications are all within the originally proposed 27-acre project site and do not result in any additional disturbed areas beyond that site, with the exception of a small area within the Contra Costa Power Plant (CCPP) property for the new well pads. Modifications to the general arrangement include elimination of one of the originally proposed two ammonia tanks (the eastern tank), relocation of the two fuel gas/dew point heaters (slightly westward), adjustment of transmission and

**ATC/PTO Application Amendment
Marsh Landing Generating Station**

other connections, relocation of the administration/control building relocation, elimination of the nitrogen system, and slight grading/drainage plan modification.

Due to the change of the power generation facility to a less-complex facility, construction of the new power generation facility is expected to occur over a 27-month period instead of the 33-month period, as discussed in previous submittals. Construction is estimated to begin in late 2010 or early 2011. Commercial operation for the MLGS is expected to commence on May 1, 2013.

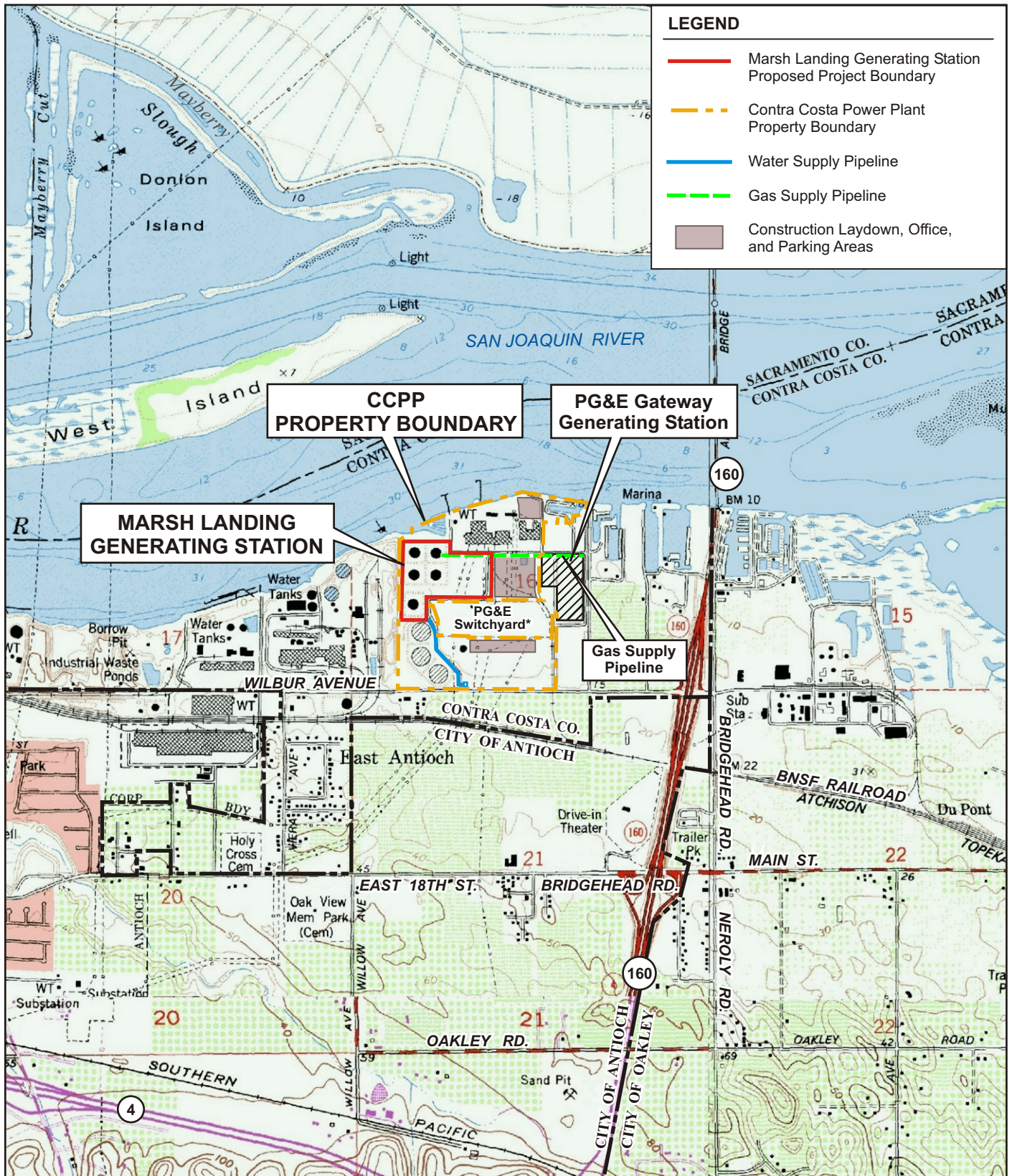

Source:
 USGS Topographic Maps, 7.5 Minute Series:
 Antioch North, California, 1978
 Antioch South, California, 1980
 Jersey Island, California, 1978
 Brentwood, California, 1978

* The PG&E Switchyard and PG&E Gateway Project are not part of the Mirant Property.

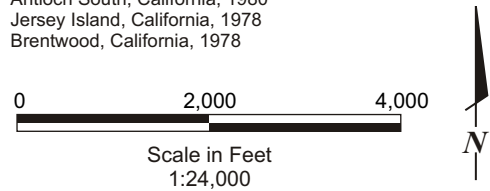

PROJECT LOCATION MAP

September 2009
 28067344
 Marsh Landing Generating Station
 Mirant Marsh Landing, LLC
 Contra Costa County, California



REVISED FIGURE 1-1



AERIAL VIEW OF PROPOSED PROJECT

September 2009
28067344

Marsh Landing Generating Station
Mirant Marsh Landing, LLC
Contra Costa County, California



REVISED FIGURE 1-2

**ATC/PTO Application Amendment
Marsh Landing Generating Station**

2.0 PROJECT DESCRIPTION

2.1 Equipment

The MLGS project will be modified from two Siemens FP10 combined-cycle units and two Simple Cycle units to four Simple Cycle units.

The Simple Cycle units will provide peaking power and are expected to operate at a maximum 20 percent capacity factor, generating approximately 760 MW (net) when operated together at 75°F temperature and 54 percent relative humidity. Each Siemens 5000F natural-gas-fired (combustion turbine generator (CTG) will be equipped with an emissions control system to include a selective catalytic reduction (SCR) and oxidation catalyst, an ammonia system, tempering air skids, a continuous emission monitoring system, and stack (see Revised Figure 2-1). The revised process flow diagram for the simple-cycle generation is shown in Revised Figure 2-2. The revised heat and material balances for the facility are also shown in Revised Figures 2-2 and 2-3 as well as in Revised Table 2-1.

With respect to project design configuration, the modification necessitates the following changes:

- The new stacks will be located so that the new westernmost stack (i.e., for one of the four Simple Cycle units) will be at the same location as the original westernmost stack of the former FP10 unit.
- The spacing between the stacks will be approximately 140 feet. The original spacing was approximately 320 feet.
- The stack heights for the new Simple Cycle units will be 165 feet. In the original plan, the stacks for the FP10s were 150 feet, 6 inches, and the stacks for the Simple Cycle units were 150 feet, 3 inches. The inner diameter of the stacks will be 31 feet, 4 inches; the same as originally proposed for the Simple Cycle units.
- The maximum annual startups and shutdowns for each Simple Cycle unit will be changed to 167. (The original Simple Cycle units had 100 startups and shutdowns per year, while the FP10s had 193 startups and shutdowns per year.)
- The maximum requested annual operating hours for the MLGS will be reduced from 8,760 hours to 1,705 hours.

**ATC/PTO Application Amendment
Marsh Landing Generating Station**

**Revised Table 2-1
Heat and Material Balance Case Descriptions – Simple-Cycle Power Blocks**

Case		Ambient Temperature (°F)	Relative Humidity (percent)	CTG Load (percent)	Evaporative Cooling
1	A	20	90	100	No
	B	20	90	75	No
	C	20	90	60	No
2	A	60	64	100	85%
	B	60	64	75	No
	C	60	64	60	No
3	A	94	32	100	Yes
	B	94	32	75	No
	C	94	32	60	No
Notes: CTG = combustion turbine generator °F = degrees Fahrenheit					

Note:
This table replaces Tables 2-1 and 2-2, because the FP10s have been eliminated.

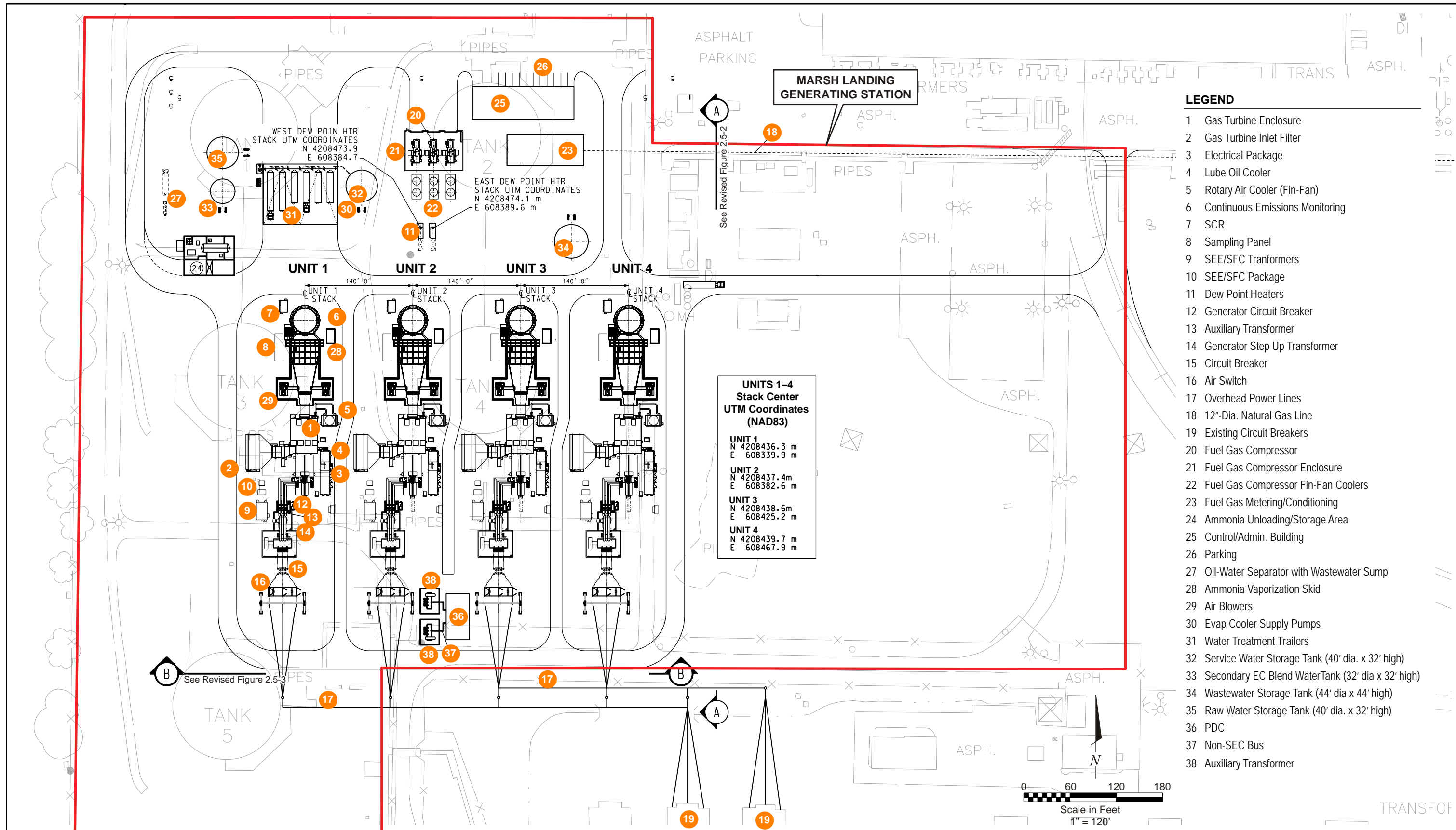

Source:
CH2MHill Lockwood Greene: General Arrangement Marsh Landing Generating Station,
Siemens Simple Cycle SGT6-5000F Equipment Layout;
Drawing No: MR-GA-ML-01-26 (Rev. H, 08/27/09)

GENERAL PLOT PLAN

September 2009
28067344
Marsh Landing Generating Station
Mirant Marsh Landing, LLC
Contra Costa County, California



REVISED FIGURE 2-1

	Units	20°F, 90% RH 100% Load	75°F, 54% RH 100% Load	94°F, 32% RH 100% Load
Gross Power Output	MW	222.3	194.7	187.5
Gross Heat Rate (LHV)	Btu/kW-hr	8,824	9,101	9,202
① Water Flow (Evap Cooler)	lb/hr	0	8,449	16,767
② Fuel Flow	lb/hr	95,311	86,112	83,814
③ Exhaust Flow	lb/hr	4,282,933	3,916,687	3,817,191
③ Exhaust Temperature	°F	1,053	1,087	1,097
④ Dilution Air Flow	lb/hr	1,860,166	2,047,291	2,114,453

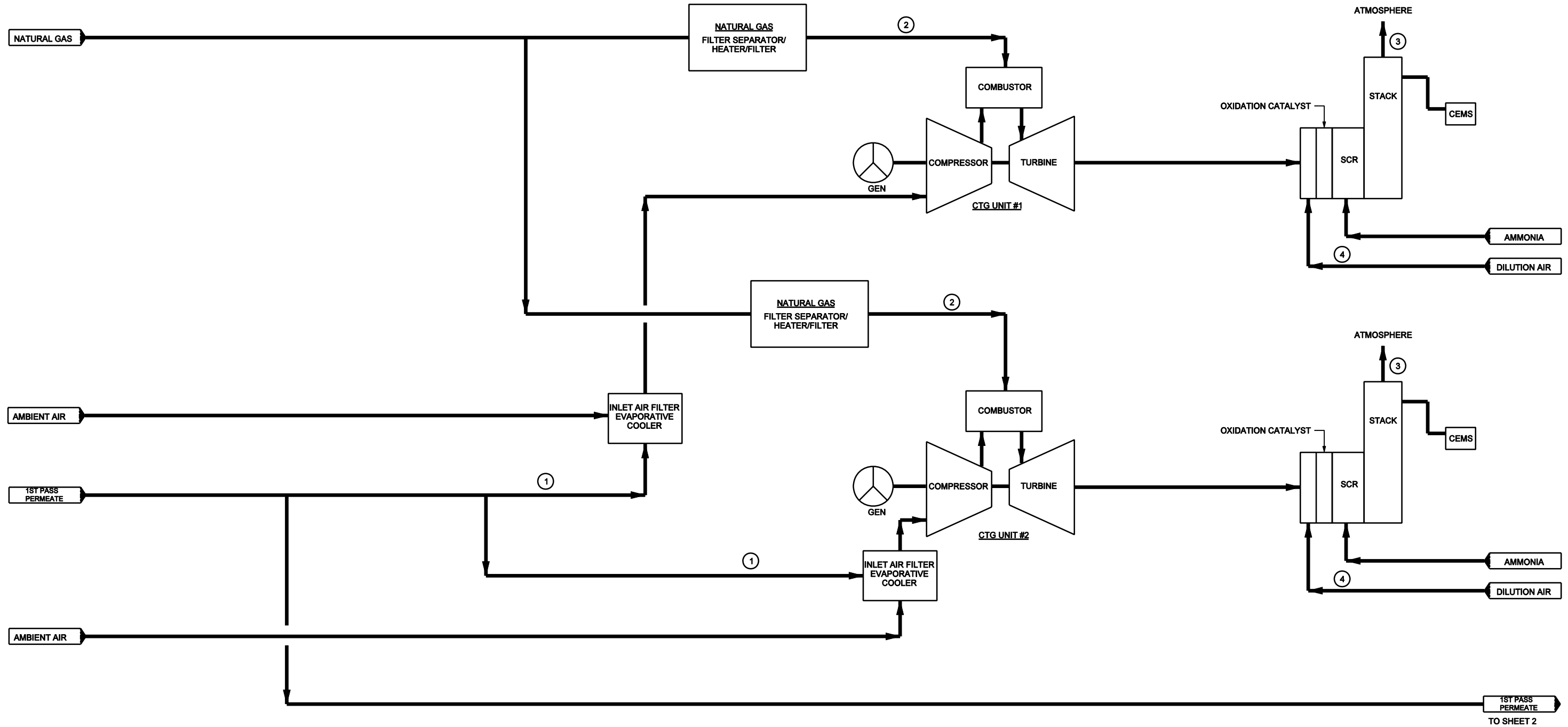

Source:
 CH2MHill Lockwood Greene; Process Flow Diagram, Marsh Landing Generation Station
 Simple Cycle Heat & Material Balance
 Drawing No: MC-PR-20-20-01 sheet 1 (Rev. Aug 2009)

**SIMPLE CYCLE UNITS 1 AND 2
 HEAT AND MATERIAL BALANCE**

September 2009
 28067344
 Marsh Landing Generating Station
 Mirant Marsh Landing, LLC
 Contra Costa County, California



REVISED FIGURE 2-2

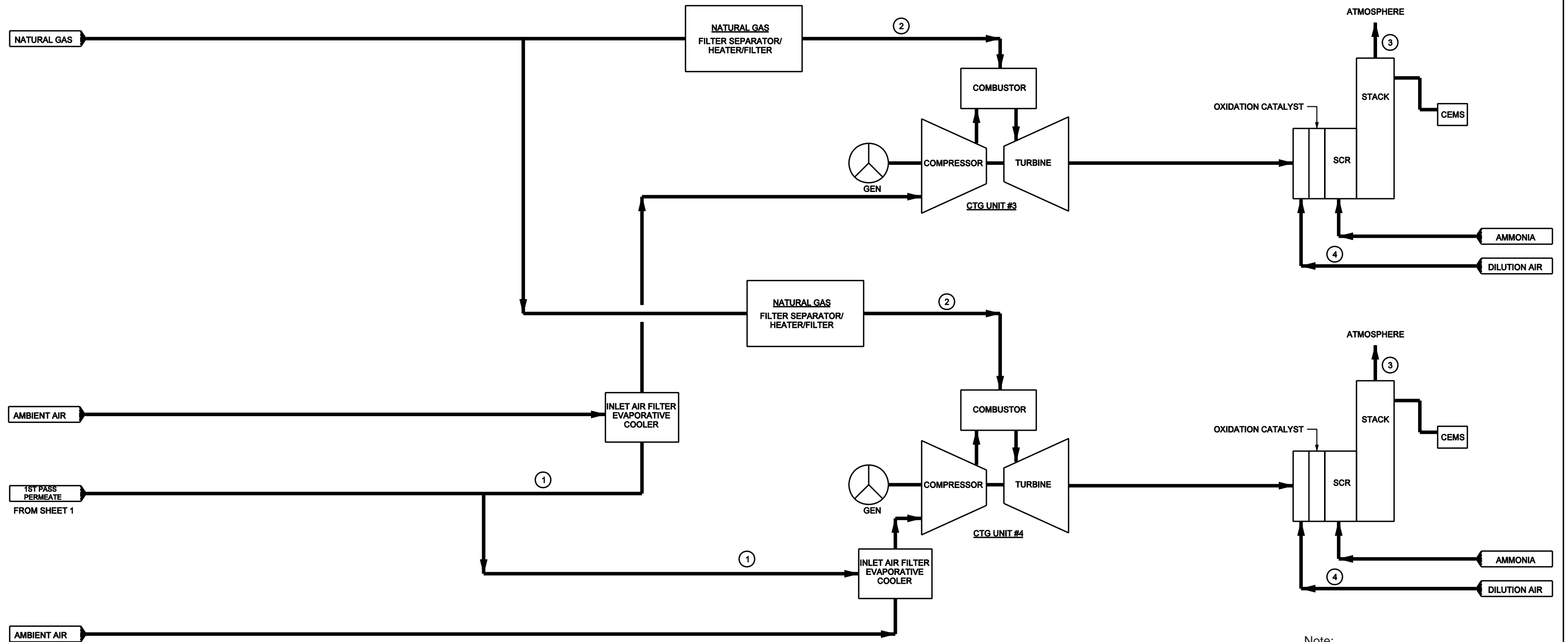

Note:
See Table on Revised Figure 2.5-5
for Heat and Material Balance values.

Source:
CH2MHill Lockwood Greene; Process Flow Diagram, Marsh Landing Generation Station
Simple Cycle Heat & Material Balance
Drawing No: MC-PR-20-20-011 sheet 2 (Rev. August 2009)

**SIMPLE CYCLE UNITS 3 AND 4
HEAT AND MATERIAL BALANCE**

September 2009
28067344

Marsh Landing Generating Station
Mirant Marsh Landing, LLC
Contra Costa County, California



REVISED FIGURE 2-3

**ATC/PTO Application Amendment
Marsh Landing Generating Station**

3.0 EQUIPMENT SPECIFICATIONS

3.1 Equipment List

The following list is the revised summary of equipment comprising the proposed MLGS project.

- CTG #3 Siemens SGT6-5000F Natural-Gas-Fired CTG, 190 MW; 2,202 million British Thermal Units (MMBtu) per hour with Ultra Low Nitrogen Oxides (NO_x) combustors; abated by A-1 Carbon Monoxide (CO) Catalyst System and A-2 SCR System
- S-2 CTG #3 Siemens SGT6-5000F Natural-Gas-Fired CTG, 190 MW; 2,202 MMBtu per hour with Ultra Low NO_x combustors; abated by A-3 CO Catalyst System and A-4 SCR System
- S-3 CTG #3 Siemens SGT6-5000F Natural-Gas-Fired CTG, 190 MW; 2,202 MMBtu per hour with Ultra Low NO_x combustors; abated by A-5 CO Catalyst System and A-6 SCR System
- S-4 CTG #4 Siemens SGT6-5000F Natural-Gas-Fired CTG, 190 MW; 2,202 MMBtu per hour with Ultra Low NO_x combustors; abated by A-7 CO Catalyst System and A-8 SCR System
- S-5 Fuel Gas Preheater; Natural-Gas-Fired, 5.00 MMBtu per hour; Serving S-1 and S-2
- S-6 Fuel Gas Preheater; Natural-Gas-Fired, 5.00 MMBtu per hour; Serving S-3 and S-4
- A-1 CO Catalyst System #1 abating emissions from CTG #1 (S-1)
- A-2 SCR System #1 abating emissions from CTG #1 (S-1)
- A-3 CO Catalyst System #2 abating emissions from CTG #2 (S-2)
- A-4 SCR System #2 abating emissions from CTG #2 (S-2)
- A-5 CO Catalyst System #3 abating emissions from CTG #3 (S-3)
- A-6 SCR System #3 abating emissions from CTG #3 (S-3)
- A-7 CO Catalyst System #4 abating emissions from CTG #4 (S-4)
- A-8 SCR System #4 abating emissions from CTG #4 (S-4)
- P-1 Stack #1 releasing emissions from CTG #1 (S-1) after being abated by CO Catalyst System #1 (A-1) and SCR System #1 (A-2)
- P-2 Stack #2 releasing emissions from CTG #2 (S-3) after being abated by CO Catalyst System #2 (A-3) and SCR System #2 (A-4)
- P-3 Stack #3 releasing emissions from CTG #3 (S-5) after being abated by CO Catalyst System #3 (A-5) and SCR System #3 (A-6)
- P-4 Stack #4 releasing emissions from CTG #4 (S-6) after being abated by CO Catalyst System #4 (A-7) and SCR System #4 (A-8)
- P-5 Fuel Gas Preheater Emission Point following natural-gas-fired fuel preheater (S-5)
- P-6 Fuel Gas Preheater Emission Point following natural-gas-fired preheater (S-6)

**ATC/PTO Application Amendment
Marsh Landing Generating Station**

4.0 EXPECTED EMISSIONS

This section discusses the change in expected emissions from the proposed power blocks. Emissions of both criteria pollutants and hazardous air pollutants (HAPs) were estimated. These emission rates will be used to show that the MLGS project will not cause an exceedance of Prevention of Significant Deterioration (PSD) increments, California or federal ambient air quality standards (AAQS), or significant health risk measures.

4.1 Gas Turbine Criteria Pollutant and Hazardous Air Pollutant Emissions

During normal plant operation, the only emission sources of the project will be the four Siemens Simple Cycle units and the two fuel gas preheaters (also referred to as dew point heaters). Maximum short-term operational emissions from the units were determined from a comparative evaluation of potential emissions corresponding to turbine commissioning, normal operating conditions, and CTG startup/shutdown conditions. The long-term operational emissions from the units were estimated by summing the emissions contributions from normal operating conditions and CTG startup/shutdown conditions.

Estimated annual emissions of air pollutants for the Simple Cycle units have been calculated based on the expected operating schedule for the units presented in Revised Table 4-2.

The criteria pollutant emissions rates and stack parameters were provided by the unit vendors for three load conditions (60 percent, 75 percent, and 100 percent) for the Simple Cycle units at three ambient temperatures (94 °F, 60 °F, and 20 °F) are presented in Revised Table 4-3.

These cases encompass CTG operations with and without evaporative cooling of the inlet air to the turbines. The combined scenarios presented in these tables bound the expected normal operating range of each proposed unit.

An emission change not associated directly with the project modification is included in this amendment for clarity and completeness. In discussions with the regulatory agencies regarding Best Available Control Technology (BACT) for the gas turbines, the Applicant has agreed to reduce the normal operating emissions for CO and volatile organic compounds (VOCs) from the Simple Cycle units.

The CO emissions will be reduced to 2.0 parts per million (ppm), compared to 3.0 ppm in previous ATC submittals. The VOC emissions will be reduced to 1.0 ppm, compared to 2.0 ppm in previous ATC submittals. All of the above concentrations are in units of ppm, dry basis, corrected to 15 percent oxygen. The emissions of CO and VOC shown in Revised Table 4-3 reflect the lower concentrations.

The expected emissions and durations associated with Simple Cycle unit startup and shutdown events are summarized in Revised Table 4-5. No changes to the startup and shutdown times result from this amendment. However, based on discussions with the regulatory agencies, the maximum hourly emissions for two startup cases are estimated.

The first case includes a startup and the remainder of the hour at full load operation. The second case includes a startup, a shutdown, a second startup, and the remainder of the hour at full load operation. This second startup case was the basis for maximum hourly emissions for most pollutants, and represents a reasonable worst-case event in which a turbine trip occurs during a startup attempt and an immediate restart is undertaken. Based on vendor information, startup (i.e., the period from initial firing to compliance with emission limits) of the Simple Cycle units will occur within about 11 minutes. During a shutdown event, the efficiency of the emission controls will continue to function at normal operating

**ATC/PTO Application Amendment
Marsh Landing Generating Station**

levels down to a load of 60 percent for the Simple Cycle units; shutdown periods and emissions are measured from the time this load is reached.

The total combined annual emissions from all emission sources of the project are shown in Revised Table 4-6 including the four Simple Cycle units and two gas-fired preheaters. Annual emissions of all pollutants for the four Simple Cycle units were calculated with 1,752 total hours, with 167 startups, 167 shutdowns, and 1,705 hours of normal operation at full load at the yearly average temperature of 60 °F.

HAP emissions rate for the units have been calculated based on the expected operating schedule for the units presented in Revised Table 4-8.

4.2 Gas-Fired Fuel Preheater Criteria Pollutant and HAP Emissions

Each preheater serves one pair of combustion turbine. Each preheater is rated at of 5.00 MMBTU per hour heat input, and were conservatively assumed to be operating at full capacity to treat the gas fuel to the turbines. Because the operation schedule of fuel preheaters depend on the turbine schedule, the revised annual criteria pollutant emissions due to the project modification are shown in Revised Table 4-6. HAP emissions are shown in Revised Table 4-10.

**Revised Table 4-2
Maximum Simple Cycle Unit Operating Schedule and Stack Parameters**

Operating Conditions	Annual Numbers
Number of Cold Starts per Turbine	167
Number of Shutdowns	167
Startup Time (minutes)	11
Shutdown Time (minutes)	6
Turbine Operation (hours)	1,705
Total Operation (hours)	1,752
Stack Height (feet)	165
Stack Diameter (feet)	31.33

Note:

This table replaces Tables 4-1 and 4-2, because the FP10s have been eliminated.

**ATC/PTO Application Amendment
Marsh Landing Generating Station**

**Revised Table 4-3
1-Hour Operating Emission Rates for Simple Cycle Units**

Case	Units	1A	1B	1C	2A	2B	2C	3A	3B	3C
Ambient Temperature	°F	Winter Extreme: 20°F/90% RH			Yearly Average: 60°F/64%RH			Summer Design: 94°F/32%RH		
CTG Load Level	%	100%	75%	60%	100%	75%	60%	100%	75%	60%
Evap Cooling Status	OFF/ON	OFF	OFF	OFF	85%	OFF	OFF	ON	OFF	OFF
Gas Turbine Outlet Temperature	°F	1,065	1,065	1,065	1,090	1,090	1,091	1,123	1,123	1,122
Stack Outlet Temperature	°F	750	750	750	750	750	750	750	750	750
Exit Velocity	fps	70.9	57.6	50.8	68.3	56.6	37.2	65.9	55.4	49.1
NO _x as NO ₂ (at 2.5 ppm)	lb/hr	20.83	16.39	13.89	18.89	15.00	12.78	16.94	13.89	11.67
CO (at 2.0 ppm)	lb/hr	10.00	8.00	6.80	9.00	7.50	6.20	8.50	6.50	5.80
VOC (at 1.0 ppm)	lb/hr	2.90	2.30	1.93	2.60	2.10	1.80	2.40	1.90	1.63
PM ₁₀	lb/hr	9	8	8	8	8	8	8	8	8
SO ₂ (1 gr/100 scf)	lb/hr	6.21	4.90	4.17	5.63	4.51	3.84	5.08	4.11	3.52
Notes: CO = carbon monoxide CTG = combustion turbine generator fps = feet per second lb/hr = pounds per hour NO _x = nitrogen oxide O ₂ = oxygen PM ₁₀ = particulate matter 10 microns in diameter ppm = parts per million RH = relative humidity scf = standard cubic feet SO ₂ = sulfur dioxide VOC = volatile organic compounds										

Note:

This table replaces Tables 4-3 and 4-4, because the FP10s have been eliminated.

**ATC/PTO Application Amendment
Marsh Landing Generating Station**

**Revised Table 4-5
Criteria Pollutant Emission Rates during Startup and Shutdown**

Pollutant	Simple Cycle Units			
	Startup (11 min)	Shutdown (6 min)	Maximum Hourly 2 SU and 1 SD (lb/hr)	Maximum Hourly 1 SD (lb/hr)
	(lb/event)	(lb/event)		
NO _x (2.5 ppm)	12	10	45.1	28.8
CO (2 ppm)	213	110	544.0	119.0
VOC (1 ppm)	11	5	30.1	7.6
SO ₂ (0.4 gr/100 scf)	0.17	0.15	2.5	2.4
SO ₂ (1 gr/100 scf)	0.42	0.37	6.2	5.7
PM ₁₀	1	1	9.0	9.1
CO = carbon monoxide gr/100 scf = grains per hundred standard cubic feet NO _x = nitrogen oxide PM ₁₀ = particulate matter 10 microns in diameter ppm = parts per million SD = shutdown SO ₂ = sulfur dioxide SU = startup VOC = volatile organic compounds Notes: Startup/shutdown duration defined as operation of CTG below 60 percent load for the FP10s or 60 percent load for the Simple Cycle units when gaseous emission rates (lb/hr basis) exceed the controlled rates defined as normal operation. Startup and shutdown SO ₂ emissions are calculated based on the total amount of fuel used for each and the emission rate of SO ₂ at a winter extreme of 20 °F; 100% load. Maximum hourly emissions assume two startups, one shutdown, and the remainder of the hour at maximum normal operating rate.				

**Revised Table 4-6
Total Project Annual Emissions of Criteria Pollutants**

Pollutant	Emissions (tons/year)		
	Simple Cycle Units ¹	Fuel Gas Preheaters	MLGS Total
NO _x	71.75	0.263	72.01
CO	138.57	0.301	138.87
VOC	14.21	0.024	14.23
SO ₂	7.79	0.010	7.80
PM ₁₀	31.35	0.026	31.38
Notes: ¹ Simple Cycle Units emissions based on 1,752 hours of operation (1,705 hours of operation with 167 startups and 167 shutdowns) CO = carbon monoxide NO _x = nitrogen oxides PM ₁₀ = particulate matter less than 10 micrometers in diameter VOC = volatile organic compounds SO ₂ = sulfur dioxide			

Note:
This table replaces Tables 4-6 and 4-9, to present plant-wide annual emissions

**ATC/PTO Application Amendment
Marsh Landing Generating Station**

**Revised Table 4-8
HAPs Emission Rates from the Operation of Each 5000F Simple Cycle CTG**

Pollutant	Emission Factor (lb/MMBtu)	Hourly Emission Rate (lb/hr)	Annual Emission Rate (lb/yr)
Ammonia		32.91	5.77E+04
1,3-Butadiene	1.24E-07	2.73E-04	4.79E-01
Acetaldehyde	1.34E-04	2.95E-01	5.16E+02
Acrolein	3.62E-06	7.97E-03	1.40E+01
Benzene	3.26E-06	7.18E-03	1.26E+01
Ethylbenzene	1.75E-05	3.85E-02	6.74E+01
Formaldehyde	3.60E-04	7.93E-01	1.39E+03
Hexane	2.53E-04	5.57E-01	9.76E+02
Propylene	7.53E-04	1.66E+00	2.91E+03
Propylene oxide	4.67E-05	1.03E-01	1.80E+02
Toluene	6.93E-05	1.53E-01	2.68E+02
Xylenes	2.55E-05	5.61E-02	9.83E+01
Polycyclic Aromatic Hydrocarbons			
Benzo(a)anthracene	2.21E-08	4.86E-05	8.52E-02
Benzo(a)pyrene	1.36E-08	3.98E-05	1.32E-01
Benzo(b)fluoranthene	1.10E-08	2.43E-05	4.26E-02
Benzo(k)fluoranthene	1.07E-08	2.37E-05	4.14E-02
Chrysene	2.46E-08	5.42E-05	9.50E-02
Dibenz(a,h)anthracene	2.29E-08	5.05E-05	8.85E-02
Indeno(1,2,3-cd)pyrene	2.29E-08	5.05E-05	8.85E-02
Naphthalene	1.62E-06	3.57E-03	6.25E+00
Total Polycyclic Aromatic Hydrocarbons		3.86E-03	6.83E+00
<p>Notes: lb/hr = pounds per hour lb/MMBtu = pounds per million British thermal units lb/yr = pounds per year ¹ Hourly and annual emissions based on maximum combustion turbine generator operations. ² Annual emissions based on 1,752 hours of operations. ³ Emission factors obtained from the CATEF database for natural-gas-fired combustion turbines. Formaldehyde, benzene, and acrolein emission factors are from the background document for AP-42, Section 3.1, Table 3.4-1 for a natural-gas-fired combustion turbine with a carbon monoxide catalyst. ⁴ Ammonia emission rate based on an exhaust ammonia limit of 10 parts per million by volume at 15 percent oxygen provided by the turbine vendor. ⁵ Used a higher heating value of 1,024 British thermal units per standard cubic foot to convert emission factor units.</p>			

Note:

This table replaces Tables 4-7 and 4-8, because the FP10s have been eliminated.

Revised Table 4-10
HAPs Emission Rates from the Operation of Each Fuel Gas Preheater

Pollutant	Emission Factor (lb/MMBtu)	Hourly Emission Rate per Heater (lb/hr)	Heater for Simple Cycle Turbines – Annual Emission Rate (lb/yr)
Acetaldehyde	1.37E-05	6.84E-05	1.20E-01
Acrolein	4.73E-06	2.36E-05	4.14E-02
Benzene	1.09E-05	5.47E-05	9.58E-02
Ethylbenzene	2.20E-06	1.10E-05	1.92E-02
Formaldehyde	7.23E-05	3.61E-04	6.33E-01
Propylene	2.29E-04	1.15E-03	2.01E+00
Toluene	2.88E-05	1.44E-04	2.52E-01
Xylenes	1.40E-05	6.98E-05	1.22E-01
Polycyclic Aromatic Hydrocarbons			
Benzo(a)anthracene	1.91E-09	9.57E-09	1.68E-05
Benzo(a)pyrene	9.57E-10	4.79E-09	8.38E-06
Benzo(b)fluoranthene	1.11E-09	5.57E-09	9.75E-06
Benzo(k)fluoranthene	9.67E-10	4.83E-09	8.47E-06
Chrysene	1.36E-09	6.79E-09	1.19E-05
Dibenz(a,h)anthracene	8.96E-10	4.48E-09	7.84E-06
Indeno(1,2,3-cd)pyrene	1.14E-09	5.71E-09	1.00E-05
Naphthalene	1.09E-06	5.47E-06	9.58E-03
Total Polycyclic Aromatic Hydrocarbons		5.51E-06	9.65E-03
Notes:			
lb/hr = pounds per hour			
lb/MMBtu = pounds per million British thermal units			
lb/yr = pounds per year			
¹ Hourly and annual emissions based on maximum fuel energy consumption of 5 MMBtu/hour.			
² Annual emissions for each 5000F heater are based on 1,752 hours of operations.			
³ Emission factors obtained from the CATEF database for natural-gas-fired heaters (without controls).			
⁴ Used a higher heating value of 1,024 British thermal units per standard cubic foot to convert emission factor units.			

**ATC/PTO Application Amendment
Marsh Landing Generating Station**

5.0 LAWS, ORDINANCES, AND REGULATIONS

With the exception of the identification of the two proposed significant impact levels for particulate matter less than or equal to 2.5 microns in diameter (PM_{2.5}) shown on Revised Table 7-9, there is no change to the laws, ordinances, regulation, and standards as a result of this amendment.

**ATC/PTO Application Amendment
Marsh Landing Generating Station**

6.0 EMISSION OFFSETS

Revised estimates for required emissions reduction credits due to project operations are shown in Revised Table 6-2.

**Revised Table 6-2
Estimated Emission Credit Requirement to Offset Project Emissions**

Pollutant	Total MLGS Turbine Potential Emissions (ton/yr)	New Source Review Offset Ratio	Offsets Required (ton/yr)	Current ERC Holdings (ton/yr)	Holdings After Offsets are Deducted (ton/yr)
NO _x	72.0	1.15	82.8	485.7	402.9
CO	138.9	0	0.0	579.2	579.2
VOC	14.2	1.15	16.4	78.0	61.6
SO ₂	7.8	1	7.8	130.2	122.4
PM ₁₀	31.4	1	31.4	234.2	202.9
<p>Notes: Offset ratios are 1.15:1 for NO_x and VOC emissions on a pollutant specific basis, for each pollutant (facility wide) over 35 tons per year. Below 35 tons is 1:1. Offset ratios are 1:1 for remaining criteria pollutants. 0.4 gr/100 scf annual average natural gas sulfur.</p>					

**ATC/PTO Application Amendment
Marsh Landing Generating Station**

7.0 AMBIENT AIR QUALITY AND PSD ANALYSIS

7.1 Air Dispersion Modeling

The Air Quality Impact Analysis was performed using the same model and model option selections, and receptor locations as in the previous ATC submittals.

7.1.1 Building Wake Effects

Effects of building wakes (i.e., downwash) on the plumes from the proposed project's operational emission sources were evaluated using the U.S Environmental Protection Agency (U.S. EPA) Building Profile Input Program – Prime (BPIP-Prime) (Version 04274). However, the BPIP-Prime analysis was rerun to reflect changes in the locations and spacing of the project CTGs, as well as new locations for a number of buildings and other structures in the revised plant layout. The following structures were identified within the proposed project site to be included in the downwash analysis (the number of multiple structures are denoted with parenthesis):

- CTG–SCR stacks (4)
- Gas turbine inlet filters (4)
- Raw Water Storage Tank
- Service Water Storage Tank
- Fuel gas compressor enclosure
- Control/Administration building
- Buildings associated with existing CCPP (4)
- Existing Gateway CTG-Heat Recovery Steam Generators (2)
- Existing Gateway air cooled condenser
- Existing CCPP oil tanks (3)

Two additional water storage tanks, the Wastewater Storage Tank and the Blend Water Storage Tank, are either located sufficiently far away from the sources or are low enough that they would not cause downwash effects.

7.1.2 Meteorological Data

A copy of the meteorological data set used by Bay Area Air Quality Management District (BAAQMD) was obtained and used in this modeling analysis. An electronic copy of the meteorological data set is included on the Revised Air Quality and Public Health Modeling DVD included with this amendment.

7.1.3 Receptor Locations

The receptor grids used was unchanged due to this amendment.

7.1.4 Construction Impacts

The modifications to the MLGS will not result in an increase in the area of disturbance or increase the expected number, duration, or location of construction equipment proposed for the project.

Because the complexity of the project has been reduced and the construction schedule has been shortened (from 33 months to 27 months), the expected quantity of construction equipment and the duration of the equipment's usage proposed for the construction of the modified MLGS will be less than presented in previous ATC submittals. All construction mitigation measures agreed upon by applicant remain valid

ATC/PTO Application Amendment Marsh Landing Generating Station

and will be implemented during project construction. Therefore, significant long-term public health effects are not expected to occur as a result of project construction emissions.

7.1.5 Turbine Impact Screening Modeling

In previous ATC submittals, a turbine impact screening modeling analysis was performed to determine which CTG operating modes and stack parameters produced the worst-case offsite impacts (i.e., maximum ground-level concentrations for each pollutant and averaging time). This analysis was repeated for the amended project, but in this case only one set of simulations was needed because all four turbines in the revised project are simple-cycle CTGs.

Only the emissions from the CTGs were considered in this preliminary modeling step. The AERMOD model simulated transport and dispersion of natural gas combustion emissions released from the four 31.3-foot-diameter (9.5-meter), 165-foot-tall (50.3-meter) stacks that will serve the simple-cycle CTGs.

As in the previous turbine screening runs, the CTG stacks were modeled as point sources at their proposed locations within the project site. Revised Table 7-5 summarizes the CTG screening results for a range of nine different CTG operating loads and ambient temperature conditions.

The maximum estimated ground-level concentrations predicted to occur offsite with the unit turbine emission rates for each of the nine operating conditions shown in Revised Table 7-5 were then multiplied by the corresponding turbine emission rates for specific pollutants. The highest resulting concentration values for each pollutant and averaging time were then identified, and are presented as the bolded values in Table 7-5.

To allow for the greatest operational flexibility and obtain the absolute worst-case modeling scenario, the highest emission rate for any of the nine cases was used for normal operations modeling. The worst-case scenario is the summer maximum 60 percent load case (C3, modeling file case 9). The stack parameters associated with this case were used in most modeling runs.

The stack parameters associated with the maximum predicted impacts (case C3) were then used in all subsequent simulations of the refined AERMOD analyses described below. Note that the lower exhaust temperatures and flow rates at reduced turbine loads correspond to reduced plume rise, in some cases resulting in higher offsite pollutant concentrations than the higher base load emissions. Model input and output files for the screening modeling analysis are included with those from all other modeling tasks on the Air Quality and Public Health Modeling DVDs that are provided separately with this amendment.

7.1.6 1-Hour Startup Scenarios

The highest hourly nitrogen dioxide (NO₂) and CO impacts would be expected to occur during an hour that involves turbine startups, because the catalytic emission control equipment used with the CTGs is not fully operational during portions of each startup and shutdown. The scenario selected to result in the worst-case turbine emissions over a 1-hour period consists of two startups (each with a duration of about 11 minutes), one shutdown (with a duration of 6 minutes), and maximum full-load normal operations for the remaining 32 minutes. All four turbines were conservatively assumed to undergo this sequence of operations within the same hour.

In addition, both fuel gas preheaters were assumed to operate at full capacity during the hour. The turbine screening modeling results discussed previously indicate that maximum hourly NO₂ and CO concentrations during normal operations of the Simple Cycle turbines would occur with the stack parameters corresponding to full-load operations. However the magnitude of the emissions for both these pollutants during the worst-case 60 minutes of a four-turbine startup sequence would be higher than those

ATC/PTO Application Amendment Marsh Landing Generating Station

during normal operations at any ambient temperature condition. Because a startup is a transition from non-operation to full-load operation, the stack exhaust velocity and temperature during a portion of this worst-case hour are lower than the values indicated as “worst-case” by the turbine screening modeling.

Accordingly, modeling simulations were conducted to estimate the maximum 1-hour NO₂ and CO concentrations during a startup hour with reduced stack exhaust velocity and temperature, specifically those listed in Revised Table 7-6 for the case of 60 percent turbine load and an ambient temperature of 94 °F.

7.1.7 Refined Modeling

A refined modeling analysis was performed to estimate offsite criteria pollutant impacts from operational emissions of the proposed project. The four Simple Cycle units were modeled assuming the worst-case emissions corresponding to each averaging time, along with the turbine stack parameters that were determined in the turbine screening analysis (see above). The maximum mass emission rates that would occur over any averaging time, whether during turbine startups, normal operations, turbine shutdowns, or a combination of these activities, were used in all refined modeling analyses (see Revised Table 7-8). Full-load operation of the gas preheaters was assumed to occur during all hours of turbine operation.

7.1.8 Fumigation Analysis

Fumigation modeling was conducted in the same manner as described in the Applicant’s response to California Energy Commission Data Request 8, submitted in December 2008 (URS, 2008). However, because FP10 combined-cycle stacks are no longer a part of MLGS, SCREEN3 was run only once for the simple-cycle stack parameters. New short-term pollutant emissions were used in the fumigation analysis, and for NO_x 1-hour, CO 1-hour, and CO 8-hour emissions, higher startup and shutdown emissions were again incorporated into each emission rate.

Peak concentrations due to nocturnal inversion fumigation are presented in Revised Data Request Table 8-1. Maximum predicted concentrations include impacts from all four turbines. For the Simple Cycle units, the peak shoreline fumigation impacts occurred when the thermal internal boundary layer (TIBL) factor was set to 6. This is confirmed by Revised Data Request Table 8-2, which shows the different Chi over Q (χ/Q) (micrograms per cubic meter per gram per second) values corresponding to different TIBL factors used in the SCREEN3 modeling analysis. Finally, peak concentrations due to shoreline inversion fumigation are presented in Revised Data Request Table 8-3. Maximum predicted concentrations include impacts from all four turbines using a TIBL factor of 6.

Modeling input and output files are included on the Revised Air Quality and Public Health Modeling DVD included with this amendment.

7.2 Compliance with Ambient Air Quality Standards and PSD Requirements

Air dispersion modeling was performed according to the methodology described above to evaluate the maximum increase in ground-level pollutant concentrations resulting from project emissions, and to compare the maximum predicted impacts, including background pollutant levels, with applicable short-term and long-term state or federal AAQS.

7.2.1 Normal Plant Operation

The emissions used for each pollutant and averaging time are explained and quantified in Revised Table 7-8. This subsection describes the maximum predicted operational impacts of the project for normal 5000F simple-cycle operating conditions. Commissioning impacts, which would occur on a

ATC/PTO Application Amendment Marsh Landing Generating Station

temporary, one-time basis and would not be representative of normal operations, were addressed separately, as described below under Turbine Commissioning.

Revised Table 7-9 summarizes the maximum predicted criteria pollutant concentrations due to the operational 5000F simple-cycle turbines. The incremental impacts of project emissions would be below the federal PSD significant impact levels for all attainment pollutants, despite the use of worst-case emissions scenarios for all pollutants and averaging times.

Revised Table 7-9 also shows that the modeled impacts due to the project emissions, in combination with conservative background concentrations, would not cause a violation of any federal AAQS and would not significantly contribute to the existing violations of the federal and state standards for particulate matter less than or equal to 10 microns in diameter (PM₁₀) and PM_{2.5}. In addition, as described later, all of the project's operational emissions of nonattainment pollutants and their precursors will be offset to ensure a net air quality benefit.

The locations of predicted maximum impacts would vary by pollutant and averaging time. Revised Figure 7-4 shows the locations of the maximum predicted operational impacts for all pollutants and averaging times

Commissioning impacts, which would occur on a temporary, one-time basis and would not be representative of normal operations, were addressed separately, as described below under Turbine Commissioning.

7.2.2 Turbine Commissioning

Emissions during commissioning of each new Simple Cycle unit will be unchanged due to this amendment. However, unlike the modeling approach for commissioning in the previous ATC submittals, modeling for this amendment was conducted assuming as a worst-case scenario that all four Simple Cycle units would be commissioned simultaneously. This was done to provide the Applicant with the most operational flexibility during the commissioning period.

Revised Table 7-12 shows the results of the model simulations for turbine commissioning. The tabulated impacts are the highest concentrations for the indicated averaging that are predicted by AERMOD to occur using 5 years of hourly meteorological input data. The modeling was conducted for commissioning of four simple-cycle turbines simultaneously under worst-case emission conditions. Revised Table 7-12 demonstrates that when the maximum incremental commissioning impacts are added to applicable background concentrations and compared with the most stringent state or national ambient standards, no violations of the applicable standards for these pollutants are predicted to occur.

7.2.3 Impacts for Non-Attainment Pollutants and their Precursors

The emission offset program described in the BAAQMD Rules and Regulations was developed to facilitate net air quality improvement for new sources in the BAAQMD. Project impacts of non-attainment pollutants (PM₁₀, PM_{2.5}, and ozone) and their precursors (NO_x, sulfur dioxide, and VOC) will be fully mitigated by emission offsets. The emission reductions associated with these offsets have not been accounted for in the modeled impacts noted above. Thus, the impacts indicated in the foregoing presentation of model results for the project may be significantly overestimated.

7.2.4 Impacts on Air Quality Related Values in Class I Area

The Simple Cycle units will have exhaust gas exiting the stack at temperatures greater than 700 °F for all operating loads. No visible plumes will occur from these units.

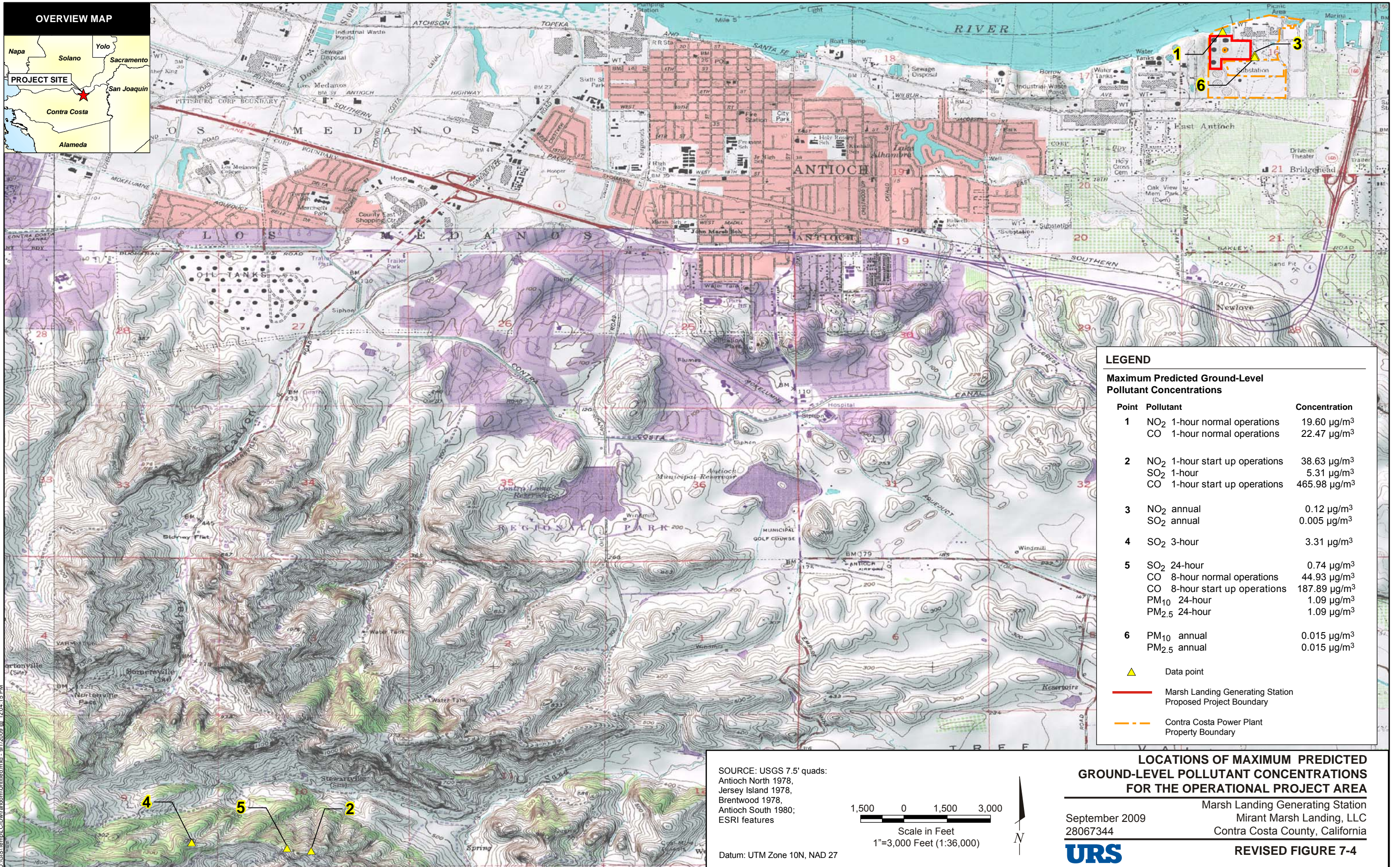

LEGEND

Maximum Predicted Ground-Level Pollutant Concentrations

Point	Pollutant	Concentration
1	NO ₂ 1-hour normal operations	19.60 µg/m ³
	CO 1-hour normal operations	22.47 µg/m ³
2	NO ₂ 1-hour start up operations	38.63 µg/m ³
	SO ₂ 1-hour	5.31 µg/m ³
	CO 1-hour start up operations	465.98 µg/m ³
3	NO ₂ annual	0.12 µg/m ³
	SO ₂ annual	0.005 µg/m ³
4	SO ₂ 3-hour	3.31 µg/m ³
5	SO ₂ 24-hour	0.74 µg/m ³
	CO 8-hour normal operations	44.93 µg/m ³
	CO 8-hour start up operations	187.89 µg/m ³
	PM ₁₀ 24-hour	1.09 µg/m ³
	PM _{2.5} 24-hour	1.09 µg/m ³
6	PM ₁₀ annual	0.015 µg/m ³
	PM _{2.5} annual	0.015 µg/m ³

- ▲ Data point
- Marsh Landing Generating Station Proposed Project Boundary
- - - Contra Costa Power Plant Property Boundary

LOCATIONS OF MAXIMUM PREDICTED GROUND-LEVEL POLLUTANT CONCENTRATIONS FOR THE OPERATIONAL PROJECT AREA

Marsh Landing Generating Station
Mirant Marsh Landing, LLC
September 2009
28067344
Contra Costa County, California

REVISED FIGURE 7-4

SOURCE: USGS 7.5' quads: Antioch North 1978, Jersey Island 1978, Brentwood 1978, Antioch South 1980; ESRI features

Datum: UTM Zone 10N, NAD 27

1,500 0 1,500 3,000
Scale in Feet
1"=3,000 Feet (1:36,000)

9/08/09 vsa .T:\Mirant Contra Costa-Marsh Landing\Graphics\Amendment 2009\Rev 7.1-5_groundlevel_pollutant.ai

Revised Table 7-5
Marsh Landing Turbine Screening Results Simple Cycle Units

Normal Operations – New Siemens SSC6-5000F Simple Cycle Gas Turbines										
Case	Case A1	Case A2	Case A3	Case B1	Case B2	Case B3	Case C1	Case C2	Case C3	
Ambient Temperature	Winter Minimum: 20°F/90% RH			Yearly Average: 60°F/64% RH			Summer Maximum: 94°F/32% RH			
CTG Load Level	100%	75%	60%	100%	75%	60%	100%	75%	60%	
Evaporative Cooler Status/Effectiveness	OFF	OFF	OFF	85%	OFF	OFF	ON	OFF	OFF	
Gas Turbine Outlet Temperature (°F)	1,065	1,065	1,065	1,090	1,090	1,091	1,123	1,123	1,122	
Stack Outlet Temperature (°F)	750	750	750	750	750	750	750	750	750	
Stack Outlet Temperature (°K)	672.04	672.04	672.04	672.04	672.04	672.04	672.04	672.04	672.04	
Stack Exit Velocity (ft/s)	70.9	57.6	50.8	68.3	56.6	50.1	65.9	55.4	49.1	
Stack Exit Velocity (m/s)	21.600	17.544	15.498	20.814	17.256	11.347	20.086	16.900	14.965	
NO _x as NO ₂ (at 2.5 ppm)	20.83	16.39	13.89	18.89	15.00	12.78	16.94	13.89	11.67	
CO (at 2.0 ppm)	10.00	8.00	6.80	9.00	7.50	6.20	8.50	6.50	5.80	
SO ₂ (lb/hr) (based on 0.4 gr total S/100 scf)	2.48	1.96	1.67	2.25	1.80	1.54	2.03	1.65	1.41	
SO ₂ (lb/hr) (based on 1.0 gr total S/100 scf)	6.21	4.90	4.17	5.63	4.51	3.84	5.08	4.11	3.52	
PM ₁₀ (lb/hr)	9.00	8.00	8.00	8.00	8.00	8.00	8.00	8.00	8.00	
NO _x (g/s)	2.627	2.067	1.752	2.382	1.892	1.611	2.137	1.752	1.471	
CO (g/s)	1.26	1.08	0.85	1.134	0.945	0.781	1.071	0.819	0.731	
SO ₂ (g/s) (based on 0.4 gr total S/100 scf)	0.313	0.247	0.210	0.284	0.227	0.194	0.256	0.208	0.178	
SO ₂ (g/s) (based on 1.0 gr total S/100 scf)	0.783	0.617	0.526	0.710	0.569	0.485	0.641	0.519	0.444	
PM ₁₀ (g/s)	1.135	1.009	1.009	1.009	1.009	1.009	1.009	1.009	1.009	
Model Results – Maximum X/Q concentration (µg/m³/(g/s)) predicted from AERMOD (all receptors)										
1-hour	1.41	1.59	1.68	1.45	1.61	1.69	1.48	1.62	1.71	
3-hour	0.922	0.998	1.05	0.932	1.01	1.06	0.941	1.02	1.07	
8-hour	0.577	0.642	0.675	0.589	0.647	0.679	0.601	0.652	0.684	
24-hour	0.200	0.222	0.234	0.204	0.224	0.235	0.208	0.226	0.237	
annual	0.009	0.011	0.013	0.009	0.011	0.013	0.010	0.012	0.014	
Maximum Concentration (µg/m³) predicted per Pollutant Normal Operations (all receptors)										
NO _x	1 hour	3.70451	4.17743	4.41389	3.80961	4.22998	4.44016	3.88843	4.25625	4.49271
	annual	0.02312	0.02890	0.03416	0.02365	0.02889	0.03415	0.02627	0.03152	0.03678
CO	1 hour	1.77817	2.00517	2.11867	1.82861	2.03039	2.13128	1.86644	2.04300	2.15650
	8 hour	0.72766	0.80963	0.85125	0.74279	0.81594	0.85629	0.75793	0.82224	0.86260
SO ₂	1 hour	1.10365	1.24454	1.31498	1.13496	1.26019	1.32281	1.15844	1.26802	1.33847
	3 hour	0.72168	0.78116	0.82187	0.72950	0.79056	0.82969	0.73655	0.79838	0.83752
	24 hour	0.15655	0.17377	0.18316	0.15968	0.17533	0.18394	0.16281	0.17690	0.18551
	annual	0.00276	0.00344	0.00407	0.00282	0.00344	0.00407	0.00313	0.00376	0.00438
PM ₁₀	24 hour	0.22700	0.25197	0.26559	0.23154	0.25424	0.26673	0.23608	0.25651	0.26900
	annual	0.00999	0.01249	0.01476	0.01022	0.01250	0.01477	0.01136	0.01363	0.01589
		Case A1	Case A2	Case A3	Case B1	Case B2	Case B3	Case C1	Case C2	Case C3

**Revised Table 7-6
 Maximum Hourly NO₂ and CO Emissions**

Pollutant and Averaging Time	Description: Turbine Load	Simple Cycle Unit Exhaust Temperature (°F)	Simple Cycle Unit Exhaust Velocity (ft/s)	Emission Rate per Simple Cycle Unit Turbine (lb/hr)
NO _x 1-hour	All turbines starting up (two startups and one shutdown) with the remainder of the period at normal operations	750	49.1	45.1
CO 1-hour	All turbines starting up (two startups and one shutdown) with the remainder of the period at normal operations	750	49.1	544.0

**Revised Table 7-8
 Criteria Pollutant Sources and Emission Totals for the Worst Case Project Emissions Scenarios for All Averaging Times**

Averaging Time	Worst-Case Emission Scenarios by Operating Equipment	Pollutant	Emissions in Pounds – Entire Period Simple Cycle Units/Turbine
1-hour	NO _x : Startup hour CO: Startup hour SO ₂ (1 gr/100 scf): Operation at 20 F ambient temp PM ₁₀ : Shutdown hour	NO _x	45.1
		CO	544.0
		SO ₂	6.2
		PM ₁₀	9.1
3-hour	SO ₂ : Three startups, two shutdowns	SO ₂	18.6
8-hour	CO: Three startups, three shutdowns, and remainder of period at full load operation at 20 °F ambient temp	CO	1040.5
24-hour	SO ₂ (1 gr/100 scf): Continuous full-load turbine operation at 20 °F ambient temperature	SO ₂	146.1
	PM ₁₀ : Three startups, three shutdowns, and the remainder of the period at continuous full-load turbine operation at 20 °F ambient temperature	PM ₁₀	214.4
Annual	NO _x , SO ₂ , PM ₁₀ : Operation for 1,752 hours at 59 °F, with 167 startups and 167 shutdowns	NO _x	35,874
		SO ₂	3,893
		PM ₁₀	15,676
Notes:			
CO = carbon monoxide			
°F = degrees Fahrenheit			
gr/100 scf = grains of sulfur per 100 standard cubic feet of natural gas			
1. Maximum impact scenarios for NO _x and CO are predicted to occur during a portion of the turbine startup sequence with less than full-load emissions and correspondingly reduced stack exhaust velocity and temperature (see discussion under Turbine Impact Screening Modeling in Section 7.			

**ATC/PTO Application Amendment
Marsh Landing Generating Station**

**Revised Table 7-9
AERMOD Modeling Results for Project Operations (All Project Sources Combined)**

Pollutant	Averaging Period	Maximum Predicted Impact ($\mu\text{g}/\text{m}^3$)	Significant Air Quality Impacts⁶ ($\mu\text{g}/\text{m}^3$)	Background Concentration ($\mu\text{g}/\text{m}^3$)¹	Total Concentration ($\mu\text{g}/\text{m}^3$)	NAAQS ($\mu\text{g}/\text{m}^3$)	CAAQS ($\mu\text{g}/\text{m}^3$)	Maximum UTMX NAD27 (m)	Maximum UTM Y NAD27 (m)
NO ₂	1-Hour	19.60 (Normal Operations)	19	122.1	141.7	NA	339	608,494	4,208,410
		38.63 (Start Up Operations)	NA	122.1	160.7	NA	339	601,000	4,199,675
	Annual	0.12	1.0	22.4	22.6	100	57	608,764	4,208,170
SO ₂	1-Hour	5.31	NA	235.8	241.1	NA	655	601,000	4,199,675
	3-Hour	3.31	25	114.4	117.7	1,300	NA	600,000	4,199,750
	24-Hour	0.74	5	26.3	27.0	365	105	600,800	4,199,700
	Annual	0.005	1.0	5.3	5.3	80	NA	608,764	4,208,170
CO	1-Hour	22.47 (Normal Operations)	2,000	4,715	4,738	40,000	23,000	608,494	4,208,410
		465.98 (Start Up Operations)	NA	4,715	5,181	40,000	23,000	601,000	4,199,675
	8-Hour	44.93 (Normal Operations)	500	2,222	2,230	10,000	10,000	600,800	4,199,700
		187.89 (Start Up Operations)	NA	2,222	2,410	10,000	10,000	600,800	4,199,700
PM ₁₀	24-Hour	1.09	5	87	87.1	150	50	600,800	4,199,700
	Annual	0.015	1.0	22	22.6	NA	20	608,764	4,208,146
PM _{2.5}	24-Hour	1.09	NA	77	77.1	35	NA	600,800	4,199,700
	Annual	0.015	NA	12	12.6	15	12	608,764	4,208,146

Notes:
¹ Background represents the maximum values measured at the monitoring stations identified in Section 7
² Results for NO₂ during operations used ozone limiting method (OLM) with ambient ozone data collected at the Bethel Island monitoring station for the years 2000-2002 and 2004-2005.
³ PM₁₀ and PM_{2.5} background levels exceed ambient standards.
⁴ All PM₁₀ emissions from project sources were also considered to be PM_{2.5}.
⁵ In February 2007, the California Air Resources Board approved new, more stringent state AAQS for NO₂ as shown in the table above. These changes became effective in March 2008.
⁶ Significant Air Quality Impact is applicable only for normal operations. SILs for PM_{2.5} are proposed.

**ATC/PTO Application Amendment
Marsh Landing Generating Station**

**Revised Table 7-12
Project Commissioning Modeling Results**

Modeling Scenario	Pollutant	Averaging Period	Maximum Estimated Impact (µg/m³)	Background¹ (µg/m³)	Total Predicted Concentration (µg/m³)	Most Stringent Standard (µg/m³)
Simple Cycle Turbines commissioning only	CO	1 hour	2,273.7	4,715	6,988.7	23,000
		8 hours	922.6	2,222	3,144.6	10,000
	NO ₂ ³	1 hour	176.3	122.1	298.4	339 ²

Notes:

¹ Background represents the maximum values measured at the monitoring stations presented in Section 7.

² In February 2007, the California Air Resources Board approved new, more stringent state AAQS for NO₂. The new standards of 339 µg/m³ (1 hour) and 57 µg/m³ (annual) became effective in March 2008.

³ NO₂ modeling for Commissioning was conducted with the OLM algorithm.

The SC units are expected to be operational by July 2011.

CO = carbon monoxide

µg/m³ = micrograms per cubic meter

NO₂ = nitrogen dioxide

**Revised Data Request Table 8-1
Peak Concentrations Due to Nocturnal Inversion Breakup Fumigation**

Pollutant	Averaging Time	Maximum Predicted Impact (µg/m³)	Background Concentration (µg/m³)¹	Total Concentration (µg/m³)	Most Stringent AAQS (µg/m³)
NO _x	1-hour	7.7	122.1	130	339
SO ₂	1-hour	1.1	235.8	237	655
	3-hour	0.9	114.4	115	1300
	24-hour	0.4	26.3	27	105
CO	1-hour	93.3	4,715	4,808	23,000
	8-hour	13.6	2,222.0	2,236	10,000
PM ₁₀ ^{2,3}	24-hour	0.5	84	85	50
PM _{2.5} ^{2,3}	24-hour	0.5	74	75	35

Notes:

AAQS = ambient air quality standard

CO = carbon monoxide

µg/m³ = micrograms per cubic meter

NO_x = nitrogen oxides

PM₁₀ = particulate matter less than or equal to 10 microns in diameter

PM_{2.5} = particulate matter less than or equal to 2.5 microns in diameter

SO₂ = sulfur dioxide

¹ Background represents the maximum values measured at the monitoring stations in Marsh Landing ATC.

² PM₁₀ and PM_{2.5} background levels exceed ambient standards.

³ All PM₁₀ emissions from project sources were also considered to be PM_{2.5}.

**Revised Data Request Table 8-2
Shoreline Inversion X/Q Values for Different Thermal Inversion Boundary Layer Factors**

TIBL Factor	5000F Simple Cycle turbine X/Q ($\mu\text{g}/\text{m}^3/\text{g}/\text{s}$)
2	0.2505
3	0.5837
4	1.027
5	1.527
6	2.024
Notes: $\mu\text{g}/\text{m}^3/\text{g}/\text{s}$ = micrograms per cubic meter per gram per second TIBL = thermal internal boundary layer	

**Revised Data Request Table 8-3
Peak Concentrations Due to Shoreline Inversion Fumigation**

Pollutant	Averaging Time	Maximum Predicted Impact ($\mu\text{g}/\text{m}^3$)	Background Concentration ($\mu\text{g}/\text{m}^3$) ¹	Total Concentration ($\mu\text{g}/\text{m}^3$)	Most Stringent AAQS ($\mu\text{g}/\text{m}^3$)
NO _x	1-hour	46.0	122.1	168	339
SO ₂	1-hour	6.3	235.8	242	655
	3-hour	3.2	114.4	118	1,300
	24-hour	0.5	26.3	27	105
CO	1-hour	554.9	4,715	5,270	23,000
	8-hour	28.1	2,222	2,250	10,000
PM ₁₀ ^{2,3}	24-hour	0.7	84	85	50
PM _{2.5} ^{2,3}	24-hour	0.7	74	75	35
Notes: AAQS = ambient air quality standard CO = carbon monoxide $\mu\text{g}/\text{m}^3$ = micrograms per cubic meter NO _x = nitrogen oxides PM ₁₀ = particulate matter less than or equal to 10 microns in diameter PM _{2.5} = particulate matter less than or equal to 2.5 microns in diameter SO ₂ = sulfur dioxide ¹ Background represents the maximum values measured at the monitoring stations in Marsh Landing ATC ² PM ₁₀ and PM _{2.5} background levels exceed ambient standards. ³ All PM ₁₀ emissions from project sources were also considered to be PM _{2.5} .					

**ATC/PTO Application Amendment
Marsh Landing Generating Station**

8.0 BACT ANALYSIS

The lowered emission levels for CO and VOC in exhaust from the Simple Cycle units (based on BACT determinations) were discussed previously in Section 4. None of the other BACT levels for the Simple Cycle units or the fuel gas preheaters changed as a result of this amendment. Revised Table 8-1 presents the proposed BACT determination for the MLGS emission sources. Please note the addition of an entry for greenhouse gas (GHG).

U.S. EPA policy on whether GHG are subject to Federal PSD Permit review is described in a December 18, 2008 memo (Johnston, 2008). At present, U.S. EPA is not requiring GHG to be regulated under PSD. However, that may change. The Applicant is including this analysis on a voluntary basis should the policy change during this application review.

The Applicant has determined that BACT for GHG for the fossil-fuel-fired simple-cycle gas turbine generators is to employ rapid start capability and limit the annual hours of operation.

GHGs have recently been identified as pollutants that may be regulated under the Clean Air Act. As such, the emissions of GHGs from proposed new projects may in the future be required to undergo BACT analysis. However, GHG emissions contribute to global warming on a global scale; therefore, project-specific impacts of GHG emissions and their resulting impacts to the local environment are difficult to specify and quantify through any approved mechanism. Therefore, the BACT for GHG from power plants cannot be evaluated on a project-specific impacts basis, but rather should be evaluated on a global or overall systemwide impacts basis.

While it is certainly a worthwhile goal to minimize GHG emissions from individual projects—a goal that MLGS reaches—the establishment of a GHG BACT limit in a one-size-fits-all approach applicable to all types of generation technologies and projects is problematic due to the displacement effects of less efficient generation by new generation technologies, as well as the integration of dispatchable resources to assist in greater usage of intermittent renewable generation resources such as wind and solar. Such an approach ignores the benefits of adding resources that will displace less efficient technologies and facilitate greater reliance on renewable resources that have zero GHG emissions. The vast majority of renewable technologies are intermittent resources that are dependent on wind and solar resources. To facilitate more and more of these types of resources, the system also needs extremely flexible, natural-gas-fired resources that can be started quickly, ramped up and down, and then shut down as needed to accommodate fluctuations in renewable production.

A larger fleet of non-GHG-emitting technologies ultimately allows the GHG-emitting facilities to operate for fewer total hours, and only when needed for backup, firming, shaping, and peaking services. In this way, the combination of a larger renewable fleet and the addition of new efficient natural-gas-fired peaking facilities will reduce GHG emissions on a system-wide basis, which is the proper goal for emissions that have a global impact.

As allowed by BAAQMD regulation 2-2-206.1, BACT can be a technique such as “good combustion practice” and does not have to include a numeric based emission limit (i.e., 2.0 ppm NO_x). This GHG BACT determination is based on the former technique. The rapid start peaker technology has zero emissions of GHG pollutants when turned off, but can come on line and be at full load and in full compliance with emissions limits all within about 11 minutes. This surpasses any other reserve techniques such as spinning reserve which, to be ready to ramp up quickly, requires low levels of GHG emissions even when not producing power. Alternatively, combined-cycle units may also cycle on and off and have better thermal efficiency at full load, but require from 3 to 6 hours of higher emissions and less than full power when starting from a cold status. The combined-cycle projects allow installation of

**ATC/PTO Application Amendment
Marsh Landing Generating Station**

equipment that improves thermal efficiency because they are typically licensed to operate for a majority of the time and can recover the cost through higher operating revenues and fuel savings. MLGS is proposed to operate no more than 20 percent of the time on an annual basis. Also, the equipment needed to improve thermal efficiency of the combined-cycle projects increases the start time.

Post-combustion GHG treatment such as carbon capture and sequestration is considered technically and economically infeasible for natural-gas-fired simple-cycle gas turbine applications because it is not commercially demonstrated. BAAQMD has identified good combustion practices as an available combustion control technology for minimizing unburned fuel formation during combustion. MLGS will use good combustion practices to ensure proper air/fuel mixing, achieve complete combustion, and therefore minimize emissions of methane, a component of GHG.

The gas turbine technology embodied for MLGS is exactly the type of resource needed to achieve compliance with the state’s ambitious Renewable Portfolio Standard while maintaining reliable and sufficient electrical service. California’s Renewable Portfolio Standard requires load serving entities to increase their use of renewable resources such as solar and wind generation. However, as noted above, because solar and wind are intermittent resources that are dependant on nature, it is not only prudent to have a reliable backup, but required by state agencies responsible for maintaining the reliability of the electric system.

**Revised Table 8-1
Summary of Proposed BACT**

Pollutant	Control Technology	Concentration
Simple Cycle Units		
NO _x	Ultra low NO _x burner, Selective Catalytic Reduction	2.5 ppmvd (1-hour average) at 15 percent O ₂
CO	Catalytic oxidation	2.0 ppmvd at 15 percent O ₂
VOC	Catalytic oxidation	1.0 ppmvd at 15 percent O ₂
SO ₂	Pipeline quality natural gas	N/A
PM ₁₀	Pipeline quality natural gas	N/A
Ammonia slip	Operational limitation	10.0 ppmvd at 15 percent O ₂
Greenhouse Gases	Rapid Start Technology, Limit on Annual Usage	N/A
Notes: BACT = Best Available Control Technology CO = carbon monoxide NA = not applicable NO _x = nitrogen oxides O ₂ = oxygen PM ₁₀ = particulate matter less than or equal to 10 microns in diameter ppm = parts per million SCR = Selective catalytic reduction VOC = Volatile organic compounds SO ₂ = sulfur dioxide		

**ATC/PTO Application Amendment
Marsh Landing Generating Station**

9.0 HEALTH RISK ASSESSMENT

This section describes the evaluation of potential public health risks due to demolition, construction, and operation of the proposed power generation facility and the methodology and results of the human health risk assessment (HRA). HRA is based on the project's emissions of toxic air contaminants (TACs) and the approach used in this amendment is the same approach described in the previous ATC submittals. The HRA was reassessed to be consistent with the project modifications and resultant changes in predicted air emissions presented in Section 7.

9.1 Public Health Impact Assessment Approach

The approach used in this amendment is the same approach described in previous ATC submittals.

9.2 Construction Phase Emissions

The modifications to the MLGS will not result in an increase in the area of disturbance or alter the location of the construction activities. Because the complexity of the project has been reduced and the construction schedule has been shortened (from 33 months to 27 months), the expected quantity of construction equipment and the duration of the equipment's usage proposed for the construction of the modified MLGS will be less than presented in previous ATC submittals. All construction mitigation measures agreed upon by applicant remain valid and will be implemented during project construction. Therefore, significant long-term public health effects are not expected to occur as a result of project construction emissions.

9.3 Operational Phase Emissions

The modified facility operations were evaluated to determine whether particular substances would be used or generated at the project site that could cause adverse health effects upon their release to the air.

Based on BAAQMD and Office of Environmental Health Hazard Assessment guidelines, a list of pollutants with potential cancer and non-cancer health effects associated with the emissions from the modified project are listed in Revised Table 9-1. These substances are the same substances that were identified for the HRA conducted in the ATC submittals for the original project. For the modified project, the four Simple Cycle units and the two natural-gas-fired preheaters are the only sources of TACs associated with normal MLGS operations.

Worst-case estimates of TAC emissions from the modified project are based on the following:

- Each Simple Cycle turbine would operate with a maximum higher heating value (HHV) fuel energy input rate of 2,202 million MMBtu per hour (100 percent load at 20 °F, for 1,752 hours per year).
- Each natural-gas-fired preheater would operate with a maximum HHV fuel energy input rate of 5 MMBtu per hour and will operate during every hour of turbine operation (1,752 hours per year).

Model simulations to estimate both hourly and annual average impacts from the modified project used the following stack parameters:

ATC/PTO Application Amendment Marsh Landing Generating Station

- For the Simple Cycle turbines, exhaust temperature and stack exhaust velocity values corresponding to 60 percent load at an ambient temperature of 94 °F, with no evaporative cooling.
- For the natural-gas-fired preheaters, exhaust temperature and stack exhaust velocity values corresponding to operation at maximum capacity.

The turbine emission parameter combinations were determined from the turbine screening modeling described in Section 7 to produce the highest ground-level impacts outside the project site. This parameter combination ensures that impacts from the HRA will not be underestimated for any operating condition.

The emission factors and estimated maximum hourly and annual emissions from each Simple Cycle CTG are presented in Revised Table 9-3. While the emission factors and hourly emission rates for each pollutant are the same as presented in original Table 9-3 for the Simple Cycle CTGs, the annual emission rates have increased due to the increased number of hours of operation from 877 hours to 1,752 hours per year.

The modified project no longer includes the FP10 combined-cycle units that would have operated for more than 4,000 hours per year. Emission factors for the natural-gas-fired preheaters, along with the estimated maximum hourly and annual TAC emissions, are presented in Revised Table 9-3. Under the Clean Air Act, Section 112, a major source of HAPs is a source that emits 10 tons per year or more of any HAP or 25 tons per year or more of any combination of HAPs. The modified project is not a major source of HAPs.

At the request of BAAQMD, an additional analysis was conducted to estimate the potential health risks to offsite workers due to operation of the project. The cancer risk was estimated using the default worker parameters of a 40-year exposure for 8 hours per day and 245 days per year. The chronic and acute total hazard indices (THIs) were estimated in the same manner as at the other receptors.

9.4 Estimated Lifetime Cancer Risk

The maximum incremental cancer risk resulting from project emissions was estimated to be 0.026 in 1 million, located approximately 600 meters southeast of the MLGS boundary (receptor located at 609,244 meters east, 4,207,735 meters north¹). The peak cancer risk predicted at a sensitive receptor was 0.020 in 1 million, at the Live Oak Community Christian Church, approximately 2 kilometers southeast of the project boundary (610,540 meters east, 4,206,910 meters north). The maximum predicted cancer risk for an offsite worker was 0.0036 approximately 500 meters southeast of the property boundary. Revised Table 9-2 presents the detailed cancer risk results of the HRA for the project operations.

The estimated cancer risks at all locations due to the modified project are slightly lower than the estimates for the original project, and are still well below the significance criterion of 10 in 1 million and the Toxic Best Available Control Technology (TBACT) threshold of 1 in 1 million. Thus, the project emissions are expected to pose a less-than-significant increase in terms of carcinogenic health risk. All HARP and AERMOD model files are provided electronically on the Air Quality and Public Health Modeling File DVD that is supplied separately with this amendment.

¹ Coordinates are provided in accordance with the Universal Transverse Mercator and North American Datum, 1927, Zone 10.

**ATC/PTO Application Amendment
Marsh Landing Generating Station**

9.5 Estimated Chronic and Acute Total Hazard Indices

The maximum chronic THI resulting from project's operational emissions was estimated to be 0.001 at a location approximately 600 meters southeast of the MLGS boundary (609,244 meters east, 4,207,760 meters north). The maximum predicted chronic THI at a sensitive receptor due to TAC emissions of the project was 0.0009, at the Live Oak Community Christian Church, approximately 2 kilometers southeast of the project boundary (610,540 meters east, 4,206,910 meters north). The maximum chronic THI was predicted at an offsite worker receptor was 0.0012 approximately 500 meters southeast of the property boundary.

The maximum acute THI resulting from project emissions was estimated to be 0.052 at a location approximately 11 kilometers southwest of the project (601,000 meters east, 4,199,675 meters north). The maximum acute THI at a sensitive receptor was estimated to be 0.028, at the Bridgeway Church, approximately 2 kilometers south of the project boundary (609,233 meters east, 4,206,127 meters north). Revised Table 9-2 presents the detailed noncancer results of the HRA for the project operations. The maximum acute THI predicted at an offsite worker receptor was 0.029, approximately 500 meters southeast of the property boundary.

The estimated chronic and acute THIs are well below the significance criterion of 1.0 and the TBACT chronic threshold of 0.2. Thus, the project emissions of noncarcinogenic TACs would not be expected to pose a significant risk.

9.6 Criteria Pollutants

As presented in Section 7 of this amendment, the results of the air quality analysis show that the modified project would not cause a violation of any state or federal AAQS and would not significantly contribute to existing violations of federal standards. Therefore, no significant adverse health effects are anticipated to result from the modified project's criteria pollutant emissions.

**ATC/PTO Application Amendment
Marsh Landing Generating Station**

**Revised Table 9-1
Toxicity Values Used To Characterize Health Risks**

Compound	Sources of Emissions	Inhalation Cancer Potency Factor (mg/kg-day)⁻¹	Chronic REL (µg/m³)	Acute REL (µg/m³)
Ammonia	Turbines	NA	2.0E+02	3.2E+03
1,3-Butadiene	Turbines	6.0E-01	2.0E+01	NA
Acetaldehyde	Turbines and preheaters	1.0E-02	9.0E+00	NA
Acrolein	Turbines and preheaters	NA	6.0E-02	1.9E-01
Benzene	Turbines and preheaters	1.0E-01	6.0E+01	1.3E+03
Ethylbenzene ¹	Turbines and preheaters	8.7E-03	2.0E+03	NA
Formaldehyde	Turbines and preheaters	2.1E-02	3.0E+00	9.4E+01
Hexane	Turbines	NA	7.0E+03	NA
Propylene	Turbines and preheaters	NA	3.0E+03	NA
Propylene oxide	Turbines	1.3E-02	3.0E+01	3.1E+03
Toluene	Turbines and preheaters	NA	3.0E+02	3.7E+04
Xylenes	Turbines and preheaters	NA	7.0E+02	2.2E+04
Polycyclic Aromatic Hydrocarbons				
Naphthalene	Turbines and preheaters	1.2E-01	9.0E+00	NA
Benzo(a)anthracene	Turbines and preheaters	3.9E-01	NA	NA
Benzo(a)pyrene	Turbines and preheaters	3.9E+00	NA	NA
Benzo(b)fluoranthene	Turbines and preheaters	3.9E-01	NA	NA
Benzo(k)fluoranthene	Turbines and preheaters	3.9E-01	NA	NA
Chrysene	Turbines and preheaters	3.9E-02	NA	NA
Dibenz(a,h)anthracene	Turbines and preheaters	4.1E-00	NA	NA
Indeno(1,2,3-cd)pyrene	Turbines and preheaters	3.9E-01	NA	NA
Source: OEHHA/CARB, 2008				
Notes:				
NA = not applicable				
mg/kg-day = milligrams per kilogram per day				
µg/m ³ = micrograms per cubic meter				
REL = reference exposure levels				

**ATC/PTO Application Amendment
Marsh Landing Generating Station**

**Revised Table 9-2
Estimated Cancer Risk and Acute and Chronic Noncancer Total Hazard Indices Due to
MLGS Emissions of TACs**

Location	Cancer Risk	Chronic Hazard Index	Acute Hazard Index
Point of maximum impact	0.026 excess risk in 1 million	0.001 total hazard index	0.052 total hazard index
Peak risk at a sensitive receptor	0.020 excess risk in 1 million	0.0009 total hazard index	0.028 total hazard index
Peak risk at an offsite worker receptor	0.0036 excess risk in 1 million	0.0012 total hazard index	0.029 total hazard index

Appendix A. References

- CEC (California Energy Commission), 2009a. Committee Guidance on Fulfilling California Environmental Quality Act Responsibilities for Greenhouse Gas Impacts in Power Plant Siting Applications. Committee Report. CEC 700-2009-004. March.
- CEC (California Energy Commission), 2009a. Committee Guidance on Fulfilling California Environmental Quality Act Responsibilities for Greenhouse Gas Impacts in Power Plant Siting Applications. Committee Report. CEC 700-2009-004. March.
- CEC (California Energy Commission), 2009b. Framework for Evaluating Greenhouse Gas Implications of Natural Gas-Fired Power Plants in California. <http://www.energy.ca.gov/2009publications/CEC-700-2009-009/CEC-700-2009-009.PDF>. May.
- Johnston, Stephen L., 2008. Administrator, U.S. EPA. Memorandum. U.S. EPA's Interpretation of Regulations that Determine Pollutants Covered by Federal Prevention of Significant Deterioration (PSD) Permit Program, December 18; notice provided at 73 Federal Register 80300 (December 13).
- Siemens, 2005. Siemens Engineering Specification 23T3387: Water Quality Recommendations for Evaporative Coolers. October 5.
- URS, 2008. Responses to Data Request Set 1 (#1-54), Application for Certification (08-AFC-03) for Marsh Landing Generating Station, December.



Revised Appendix B: Additional Figures

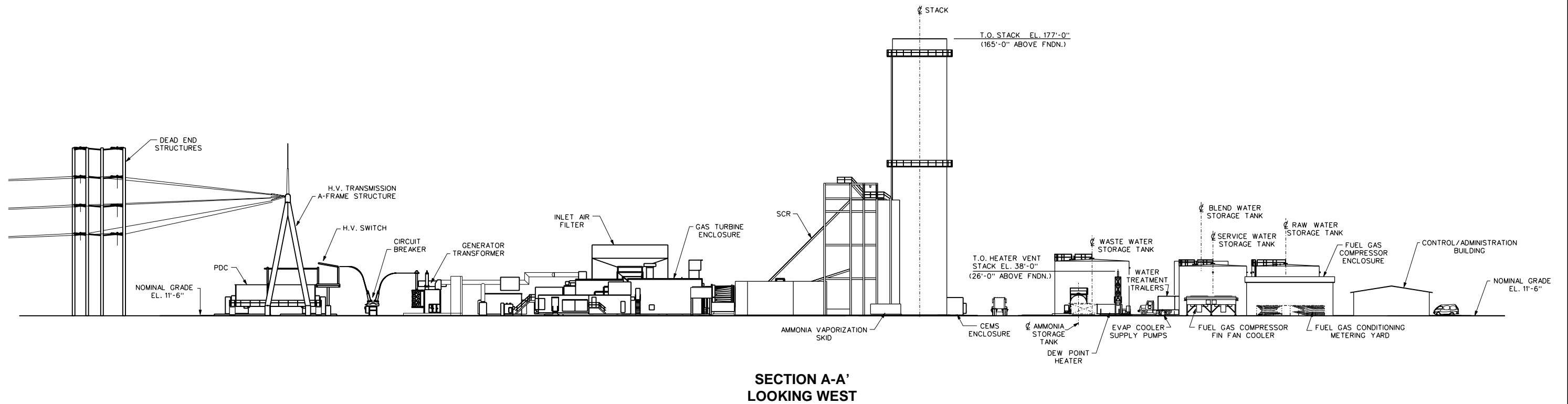

0 60
Approximate Scale in Feet

Source:
CH2MHill Lockwood Greene; General Arrangement, Marsh Landing Generating Station
Siemens Flex Simple Cycle SGT6-5000F Elevation Views;
Drawing No: MR-GA-ML-01-27 (Rev. B, 8/28/09)

Note:
See Revised Figure B-1 for Section Location.

**ELEVATION VIEW:
SIMPLE CYCLE UNITS LOOKING WEST**

September 2009
28067344

Marsh Landing Generating Station
Mirant Marsh Landing, LLC
Contra Costa County, California

URS

REVISED FIGURE B-2

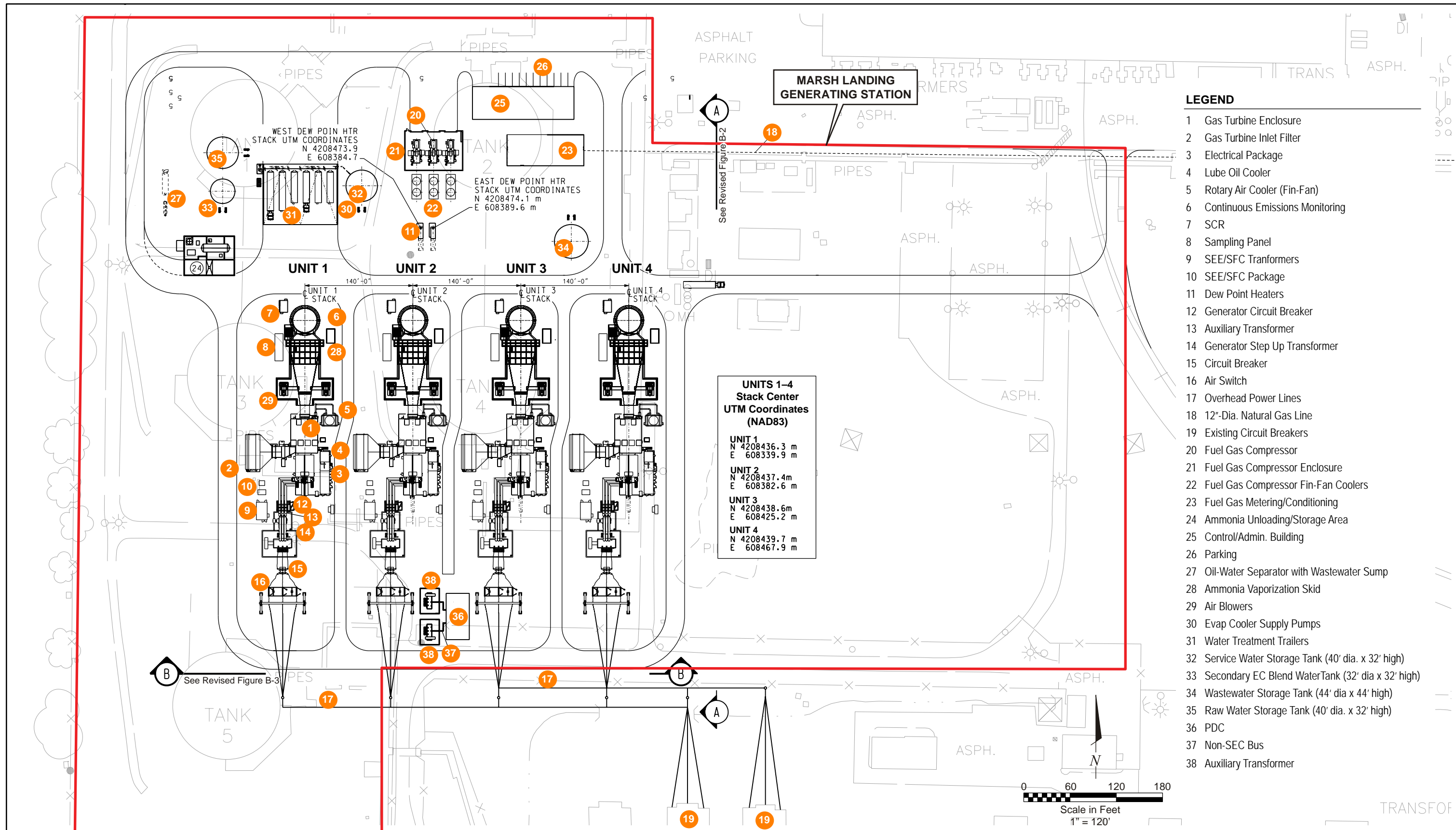

Source:
CH2MHill Lockwood Greene: General Arrangement Marsh Landing Generating Station,
Siemens Simple Cycle SGT6-5000F Equipment Layout;
Drawing No: MR-GA-ML-01-26 (Rev. H, 08/27/09)

GENERAL PLOT PLAN

September 2009
28067344
Marsh Landing Generating Station
Mirant Marsh Landing, LLC
Contra Costa County, California



REVISED FIGURE B-1

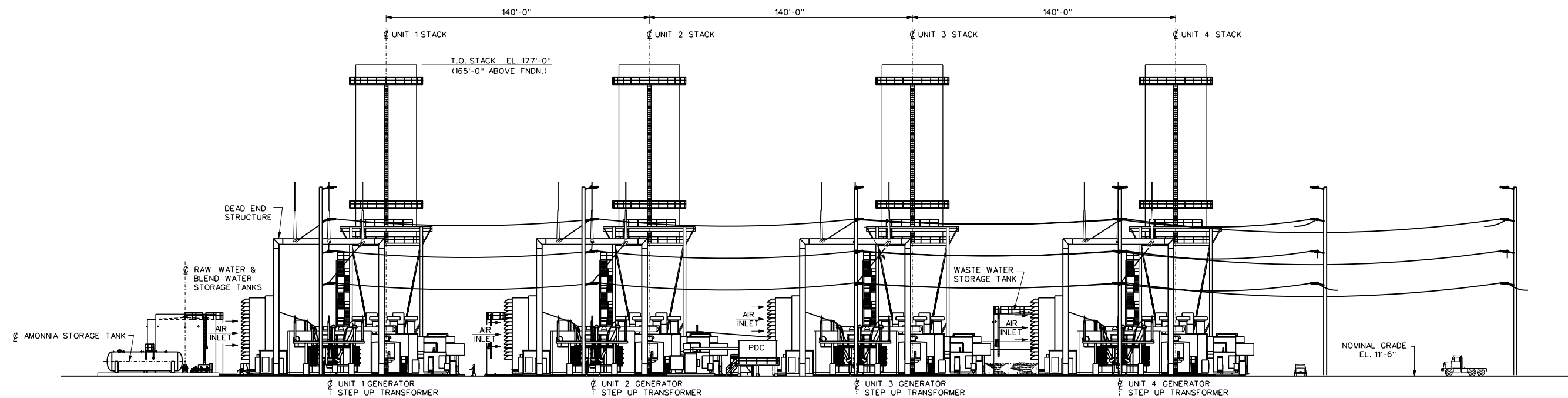

SECTION B-B'
LOOKING NORTH

0 60
Approximate Scale in Feet

Source:
CH2MHill Lockwood Greene: General Arrangement, Marsh Landing Generating Station
Siemens Flex Simple Cycle SGT6-5000F Elevation Views;
Drawing No: MR-GA-ML-01-27 (Rev. B, 8/28/09)

Note:
See Revised Figure B-1 for Section Location.

ELEVATION VIEW:
SIMPLE CYCLE UNITS LOOKING NORTH

September 2009
28067344

Marsh Landing Generating Station
Mirant Marsh Landing, LLC
Contra Costa County, California



REVISED FIGURE B-3

Revised Appendix C. Emissions Calculations

**Mirant - Marsh Landing Generating Station
SiemensSSC6-5000F Simple Cycle Gas Turbines
Potential Emission Estimates**

Turbine Operating Parameters

Ambient Temperature	UNITS	Winter Minimum (20°F / 90%RH)			Yearly Average (60°F / 64% RH)			Summer Maximum (94°F)		
		100%	75%	60%	100%	75%	60%	100%	75%	60%
CTG Load Level	%	100%	75%	60%	100%	75%	60%	100%	75%	60%
Evap Cooling Status	On / Off	Off	Off	Off	85%	OFF	OFF	On	Off	Off
Gas Turbine Outlet Temperature	°F	1,065	1,065	1,065	1,090	1,090	1,091	1,123	1,123	1,122
Stack Outlet Temperature	°F	750	750	750	750	750	750	750	750	750
Dilution Air Inlet Temperature	°F	25	25	25	64	64	64	99	99	99
Dilution Air Flow Rate	lbm/hr	1,971,557	1,601,991	1,416,082	2,071,246	1,718,357	1,525,648	2,189,638	1,842,995	1,630,352
Dilution Air Flow Rate	lbmol/hr	68,079	55,317	48,898	71,521	59,336	52,681	75,609	63,639	56,297

Average Emission Rates from each Gas Turbine (lbs/hr/turbine) - Normal Operation

(Reference: Siemens Turbine/Site Specific Information)	UNITS	Winter Minimum (20°F / 90%RH)			Yearly Average (60°F / 64% RH)			Summer Maximum (94°F)		
Heat Input, LHV	MMBtu/hr	1,984	1,565	1,333	1,800	1,441	1,229	1,624	1,315	1,125
Fuel Heating Value, LHV	Btu/lb	20,670	20,670	20,670	20,670	20,670	20,670	20,670	20,670	20,670
Fuel Heating Value, LHV	Btu/scf	912	912	912	912	912	912	912	912	912
Fuel Flow, LHV	scf/hr	2,174,637	1,715,376	1,461,084	1,972,957	1,579,461	1,347,091	1,780,045	1,441,354	1,233,098
Exhaust Flow	lbm/hr/turbine	4,366,477	3,547,986	3,136,246	4,021,343	3,336,206	2,953,373	3,677,383	3,095,213	2,745,451
O ₂	lbm/hr	1,072,080	880,116	787,879	1,047,892	879,547	788,662	1,026,953	874,706	782,932
CO ₂	lbm/hr	260,577	205,783	175,316	236,053	189,163	161,845	213,656	173,022	147,980
H ₂ O	lbm/hr	214,831	169,594	144,895	212,327	170,814	146,487	208,140	169,927	146,607
N ₂	lbm/hr	4,710,183	3,829,038	3,386,564	4,519,319	3,751,341	3,325,433	4,344,348	3,658,137	3,243,100
Ar	lbm/hr	80,254	65,210	57,643	76,779	63,698	56,445	73,627	62,280	55,187
NO _x as NO ₂ (@ 2.5 ppm)	lbm/hr	20.83	16.39	13.89	18.89	15.00	12.78	16.94	13.89	11.67
CO (@ 2.0 ppm)	lbm/hr	10.00	8.00	6.80	9.00	7.50	6.20	8.50	6.50	5.80
VOC (@ 1.0 ppm)	lbm/hr	2.90	2.30	1.93	2.60	2.10	1.80	2.40	1.90	1.63
SO ₂ (based on 0.4 gr total S / 100 scf)	lbm/hr	2.48	1.96	1.67	2.25	1.80	1.54	2.03	1.65	1.41
SO ₂ (based on 1.0 gr total S / 100 scf) worst-case	lbm/hr	6.21	4.90	4.17	5.63	4.51	3.84	5.08	4.11	3.52
PM ₁₀	lbm/hr	9	8	8	9	8	8	8	8	8
NH ₃ (@ 10 ppm slip)	lbm/hr	32.91	26.73	23.61	30.46	25.24	22.32	27.99	23.54	20.86
% of HC as VOC (CO @ 3 ppm)	%	29.00	28.75	28.43	28.89	28.00	29.03	28.24	29.23	28.16
Total Inerts (Flue Gas + Dilution Air)	lbm/hr	6,337,924	5,149,741	4,552,297	6,092,370	5,054,562	4,478,873	5,866,723	4,938,073	4,375,806
Stack Gas MW	lb/lbmol	28.46	28.47	28.49	28.39	28.41	28.43	28.33	28.34	28.36
Total Inerts	lbmol/hr	222,696	180,883	159,786	214,596	177,915	157,540	207,085	174,244	154,295
Total	ft ³ /min	3,278,539	2,662,970	2,352,374	3,159,287	2,619,272	2,319,317	3,048,718	2,565,228	2,271,538
Exit Velocity	fps	70.9	57.6	50.8	68.3	56.6	50.1	65.9	55.4	49.1

Notes:

All turbine operating parameters and emissions data provided by CH2M Hill based on expected operating parameters at the Contra Costa Site
 Assumed average sulfur content in gas (for annual emission): 0.4 gr total S / 100 scf
 Assumed average sulfur content in gas (for short term emissions): 1 gr total S / 100 scf
 Assumed fuel heating value: 1,015 Btu/scf
 hhv/lhv ratio: 1.11 ratio
 Stack Diameter: 31.333 ft

**Mirant - Marsh Landing Generating Station
Siemens SSC6-5000F Simple Cycle Gas Turbines
Potential Emission Estimates**

Startup / Shutdown Emissions from Turbine (1CT)

Startup			Shutdown		
11 (min. in startup)	Max 1-hr. (lb/hr)	Total (lb/ 11 min)	6 (min. in shutdown)	Max 1-hr. (lb/hr)	Total (lb/ 6 min)
NO _x (2.5 ppm)	29.0	12	NO _x	28.8	10
CO (2 ppm)	221.17	213	CO	119	110
VOC (1 ppm)	13.4	11	VOC	7.6	5
SO ₂ (based on 0.4 gr total S / 100 scf)	2.19	0.17	SO ₂	2.4	0.15
SO ₂ (based on 1.0 gr total S / 100 scf) worst-case	5.49	0.42	SO ₂ worst	5.7	0.37
PM ₁₀	8.4	1	PM ₁₀	9.1	1

Notes:

Startup and Shutdown Emissions from Mirant CC_Siemens SSC6-5000F SC Stack Emissions_04-02-08_Rev 1.xls
 Fuel use for SO₂ calculations from Mirant_Estimated SU_SD Emissions - SGT6-5000F(4) 9 ppm ULN on Natural Gas @ 59 F 3.27.08.pdf
 Estimated Startup data are from CTG ignition through 100% CTG load.
 Startup and Shutdown Emissions for NO_x, CO, VOC and PM₁₀ from data provided by Siemens based on 59°F ambient temperature.
 NO_x emissions assume SCR is not in operation (no removal).
 CO and VOC emissions assume CatOx is not in operation (no removal).
 SO₂ emissions assume complete conversion of all sulfur to SO₂.

Worst-Case 1 hr Emissions Comparisons

	1-hr. (w/2 SU 1 SD) (lb/hr)	1-hr. (w/1 SD) (lb/hr)	Max 1-hr Operating (lb/hr)
NO _x	45.1	28.8	20.8
CO	544.0	119.0	10.0
VOC	30.1	7.6	2.9
SO ₂ (based on 0.4 gr total S / 100 scf)	2.5	2.4	2.5
SO ₂ (based on 1.0 gr total S / 100 scf) worst-case	6.2	5.7	6.2
PM ₁₀	9.0	9.1	9.0

Worst-Case 1 hr Emissions per Turbine	lb/hr	g/sec
NO _x	45.1	5.68
CO	544.0	68.54
SO ₂	6.2	0.78
PM ₁₀	9.1	1.15

Notes:

SO₂ emissions are based on 1 gr/100 scf

Average Annual Emissions

			Pollutant	Turbine Emissions (lb/yr/CT)	Emissions for Four Turbines (ton/yr/4CT)
Total Hours of Operation	1,752		NO _x	35,873.6	71.7
Total Number of Cold Starts	167		CO	69,283.2	138.6
Cold Start Duration (hr)	0.18		CO ₂	413,564,565.3	827,129
			VOC	7,104.2	14.2
Total Number of Shutdowns	167		SO ₂	3,892.7	7.8
Shutdown Duration (hr)	0.10		PM ₁₀	15,676.2	31.4
Average Operation (hr)	1,705				

Notes:

Average annual emissions are calculated using yearly average- 59°F, at 100 % load.
 SO₂ emissions are based on 0.4 gr total S / 100 scf.

**Mirant - Marsh Landing Generating Station
Siemens SSC6-5000F Simple Cycle Gas Turbines
Potential Emission Estimates**

Max Annual Emissions

Annual	Turbine Emissions (lb/yr/CT)	Emissions for Four Turbines (ton/yr/4CT)
NO _x	39,188	78.4
CO	70,988	142.0
VOC	7,616	15.23
SO ₂	4,285	8.57
PM ₁₀	15,676	31.35
Notes: SO ₂ emissions are based on 0.4 gr total S / 100 scf.		

Worst-Case 3 hr Emissions per Turbine	lb/3 hr	g/sec
SO ₂	18.6	0.78
Notes: Only SO ₂ is considered for a 3-hour average Ambient Air Quality Standard. Assumes no startups or shutdowns, only "worst-case" operational emissions (winter minimum - 20°F; 100% load) SO ₂ emissions are based on 1 gr total S/100 scf		

Worst-Case 8 hr Emissions per Turbine	lb/8 hr	g/sec
CO (2ppm)	1040.5	16.39
Notes: Only CO is considered for an 8-hour average Ambient Air Quality Standard. Worst-case daily emissions assumes a total start up of : 3 Worst-case daily emissions assumes a total shut down of : 3 Remainder of time is spent at "worst-case" (winter minimum - 20°F; 100% load).		

Worst-Case 24 hr Emissions per Turbine	lb/24hr	g/sec
NO _x	548.3	2.88
CO	1200.5	6.30
VOC	115.1	0.60
SO ₂	58.4	0.31
SO ₂	146.1	0.77
PM ₁₀	214.4	1.13
Notes: Worst-case daily emissions assumes a total start up of : 3 Worst-case daily emissions assumes a total shut down of : 3 Remainder of time is spent at "worst case" (winter minimum - 20°F; 100% load)		

Mirant - Marsh Landing Generating Station
 Fuel Gas Preheater
 Potential Emission Estimates

Fuel Gas Preheater Operating Parameters

Fuel Gas Preheater Unit per pair of SSC6-5000F (FGP)	1
Hours of Operation (hr/yr)	1,752
Fuel Heat Content (Btu/scf)	1,020
Max Heat Input Capacity (MMBtu/hr)	5

	Emission Factors		Emission Rate
	lb/MCF/FGP	lb/MMBtu/FGP	lb/hr/FGP
CO	35	0.034	0.17
CO ₂	120,000	117.65	588.24
NO _x	30.6	0.03	0.15
PM ₁₀	3	0.0029	0.015
SO ₂ (based on 0.4 gr total S / 100 scf)	1.14	0.0011	0.006
SO ₂ (based on 1.0 gr total S / 100 scf) worst-case	2.85	0.0028	0.014
VOC	2.8	0.0027	0.014

Notes:
 Emission factors are from FIRE ver 6.25. Using "Fuel Gas Preheaters from natural gas" (SCC 3-10-004-04). The SCC# was obtained from <http://www.epa.gov/ttnchie1/eiip/techreport/volume02/ii10.pdf>.
 SO_x emission was calculated based on sulfur content.
 CO₂ emission factor is from AP-42, Chapter 1, section 4, "TABLE 1.4-2. Emission Factors for Criteria Pollutant and Greenhouse Gases from Natural Gas Combustion"

Modeling Worst-Case 1 hr Emissions per Fuel Gas Preheater

Pollutant	lb/hr/FGP	g/sec/FGP
CO	0.172	0.0216
NO _x	0.150	0.0189
PM ₁₀	0.015	0.0019
SO ₂ (based on 1.0 gr total S / 100 scf) worst-case	0.014	0.0018
VOC	0.014	0.0017

Average Annual Emissions

Pollutant	Fuel Gas Preheater Emissions			Emissions for Two Fuel Gas Preheaters (ton/yr/2FGP)
	lb/yr/FGP	ton/yr/FGP	g/sec/FGP	
CO	300.6	0.150	0.004	0.301
CO ₂	1,030,588	515.3	14.823	1,030.588
NO _x	262.8	0.131	0.004	0.263
PM ₁₀	25.8	0.013	0.000	0.026
SO ₂ (based on 0.4 gr total S / 100 scf)	9.8	0.005	0.000	0.010
VOC	24.0	0.012	0.000	0.024

Mirant - Marsh Landing Generating Station Potential Emissions Summary

Pollutant	Total Marsh Landing Turbines Potential Emissions (ton/yr)	PSD Threshold (ton/yr)	Exceed PSD Threshold	Amount of Exceedance (ton/yr)	New Source Review Offset Ratio	Offsets Required (ton/yr)
NO _x	72.0	40	Yes	32.0	1.15	82.8
CO	138.9	100	Yes	38.9	0	0.0
CO ₂	828,159.7					
VOC	14.2	40	No	0.0	1.15	16.4
SO ₂	7.8	40	No	0.0	1	7.8
PM ₁₀	31.4	15	Yes	16.4	1	31.4

Assumptions:
Includes emissions from (4) Siemens SSC6 Simple Cycle Combustion Turbines and (2) Fuel Gas Preheaters
Offset ratios are 1.15 : 1 for NO_x and VOC emissions on a pollutant specific basis, for each pollutant (facility wide) over 35 tons per year. Below 35 tons is 1 : 1.
Offset ratios are 1 : 1 for remaining criteria pollutants.

Average Annual Emissions	Turbine Emissions ton/yr/4CT	Fuel Gas Preheater Emissions ton/yr/2FGP	Total Emissions tons/yr/(4CT + 2FGP)
NO _x	71.75	0.263	72.01
CO	138.57	0.301	138.87
CO ₂	827,129	1,031	828,159.72
VOC	14.21	0.024	14.23
SO ₂ (based on 0.4 gr total S / 100 scf)	7.79	0.010	7.80
PM ₁₀	31.35	0.026	31.38

Worst-Case 1 hr Emissions	Turbine Emissions lb/hr/CT	Fuel Gas Preheater Emissions lb/hr/FGP	Total Emissions lb/hr/(4CT + 2FGP)	Total Emissions g/sec/(4CT + 2FGP)
NO _x	45.1	0.15	180.70	22.77
CO	544.0	0.17	2176.34	274.21
SO ₂ (based on 1.0 gr total S / 100 scf) worst-case	6.2	0.01	24.85	3.13
PM ₁₀	9.1	0.01	36.43	4.59