

**Dave Feiglstok**  
Manager

**Health, Environment & Safety**  
Chevron Products Company  
P. O. Box 1272  
Richmond, CA 94802-0272  
Tel 510 242 1400  
Fax 510 242 5353  
dmfe@chevron.com

October 1, 2014

Wayne Kino  
Director of Compliance and Enforcement  
Bay Area Air Quality Management District  
939 Ellis Street  
San Francisco, CA 94109

**Annual Update of Flare Minimization Plan - Public  
Chevron Richmond Refinery**

Dear Mr. Kino:

Attached please find the annual update of Chevron's Flare Minimization Plan (FMP).

The content of Appendices A, B, C, and D in this public version of this FMP have been blocked out. Full copies of updated Appendices A, B, C, and D will be included in a Trade Secret transmittal of the FMP, provided under separate cover.

**Trade Secret Information**

Appendices A, B, C, & D to this FMP contain refinery-confidential information and are trade secrets of Chevron Products Company (Chevron), as defined by the California Public Records Act, Government Code Section 6254.7 et seq., and 40 CFR Part 2, Subpart B, 18 USC 1905 and 5 USC 552(b)(4). Because of the sensitive and competitive nature of the information, Chevron Products Company requests that the BAAQMD afford the information Confidential Business Information treatment indefinitely.

If you have any questions, please contact Mr. Matt Diaz at (510) 242-1895.

Yours truly,

Dave Feiglstok

Attachments



RECEIVED

2014 OCT -3 AM 10:50

BAY AREA AIR QUALITY  
MANAGEMENT DISTRICT

# Flare Minimization Plan

Chevron Products Company - Richmond Refinery

Public Version



**CHEVRON PRODUCTS COMPANY**

**Flare Minimization Plan**

**Richmond Refinery**

**Submitted to**

**Bay Area Air Quality Management District**

**August 1, 2006**

**Revised July 10, 2007**

**Revised July 26, 2007**

**Updated July 10, 2008**

**Updated October 1, 2009**

**Updated October 1, 2010**

**Updated October 1, 2011**

**Updated October 1, 2012**

**Updated October 1, 2013**

**Updated October 1, 2014**

---

## TABLE OF CONTENTS

<b>Section</b>	<b>Page</b>
<b>Executive Summary</b>	1
<b>1.0 Introduction</b>	4
1.1 Background Information on Flare Systems	4
1.2 Trade Secret Information	8
<b>2.0 Technical Data</b>	8
2.1 Description of Flaring Systems	8
2.2 Detailed Diagrams for Flaring Systems	13
2.3 Monitoring and Control Equipment	14
<b>3.0 Past Reductions</b>	17
<b>4.0 Planned (Future) Reductions</b>	22
<b>5.0 Prevention Measures</b>	24
5.1 Major Maintenance Activities	24
5.2 Gas Quality and/or Quantity Issues	47
5.3 Recurrent Failure	59
5.4 Other Potential Flaring Events	60

### Appendices

Appendix A – Simplified Flow Diagrams

Appendix B – Flare P&IDs

Appendix C – Flare Elevation Drawings

Appendix D – Technical Summaries of Compressors and Fuel Gas System

Appendix E – D&R Flare Relief and Mitigation Project: Project Specific Addendum

---

<b>Index to Tables</b>	<b>Page</b>
Table 2-1, Flare System Drawings	8
Table 2-2, North Yard Flare System Plant Sources	12
Table 2-3, South Yard Flare System Plant Sources	13
Table 2-4, Flare P&IDs	13
Table 2-5, Flare Elevation Drawings	14
Table 2-6, Flare System Flowmeters	14
Table 2-7, Water Seal Level Indicators and Flare Vent Gas Pressure	16
Table 3-1, Historical Changes to Reduce Flaring	17
Table 4-1, Planned Improvements to Reducing Flaring	22
Table 5-1, Past Flaring During Major Maintenance Activities and Improvements Implemented	27
Table 5-1a, Flaring Activities Requiring Causal Analyses (June 2006 – June 2011)	34
Table 5-2, Flare Gas Recovery System Capacities	52
Table 5-3, Capital Cost Estimates for Increased Recovery Capacity	56
Table 5-4, Reportable Flaring Events Attributable to the Same Equipment Item	60

---

<b>Index to Figures</b>	<b>Page</b>
Figure 1-1, Simple Schematic - Flare System with Flare Gas Recovery	5
Figure 5-1, Flare Planning Process Flowchart	47
Figure 5-2, Flare Gas Recovery System with Additional Capacity	54

**Certification Statement**

Based on information and belief formed after reasonable inquiry, I, Richmond Refinery HES Manager, certify that the flare minimization plan is accurate, true, and complete.

  
\_\_\_\_\_

Signature

October 1, 2014

Date

## Executive Summary

This Flare Minimization Plan (FMP) for the Chevron Richmond Refinery (the “Richmond Refinery”) is provided pursuant to the requirements of Regulation 12, Rule 12, which was adopted by the Bay Area Quality Management District (BAAQMD) on July 20, 2005. The FMP defines a series of measures intended to reduce flaring to the extent that is feasible without compromising safety and necessary refinery operations and practices. It is the Richmond Refinery’s policy that flare events will only occur within the scope of Reg. 12-12, and that we will adjust the operation of process units to prevent flaring when consistent with safe and reliable operations.

### **Time Period Covered by the FMP Update (the “FMP Year”)**

Pursuant to Regulation 12, Rule 12, Section 404.1 (12-12-404.1), the Annual Update is due 12 months after approval of the initial FMP and annually thereafter. To ensure consistency in the FMP Updates are due no later than October 1 each year. The FMP Update due October 1, 2014 will cover the 12-month period from July 1, 2013 to June 30, 2014.

### **Graphics Depicting Progress of Flare Minimization**

The Richmond Refinery has achieved significant reductions in flaring volumes and emissions during the previous 12 months. The following graphics demonstrate this reduction in flaring since 2004. The first graphic displays the annual average quantities of vent gas flow. The second graphic displays the annual average methane, non-methane hydrocarbon (NMHC), and sulfur dioxide (SO<sub>2</sub>) emissions.

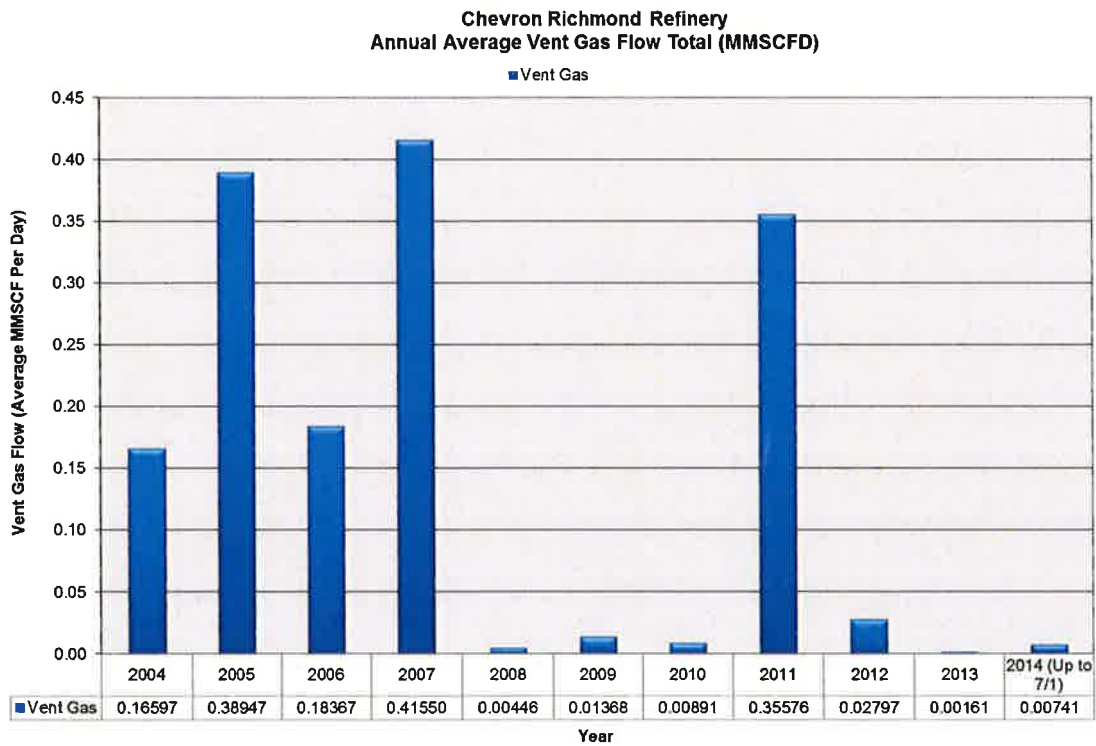

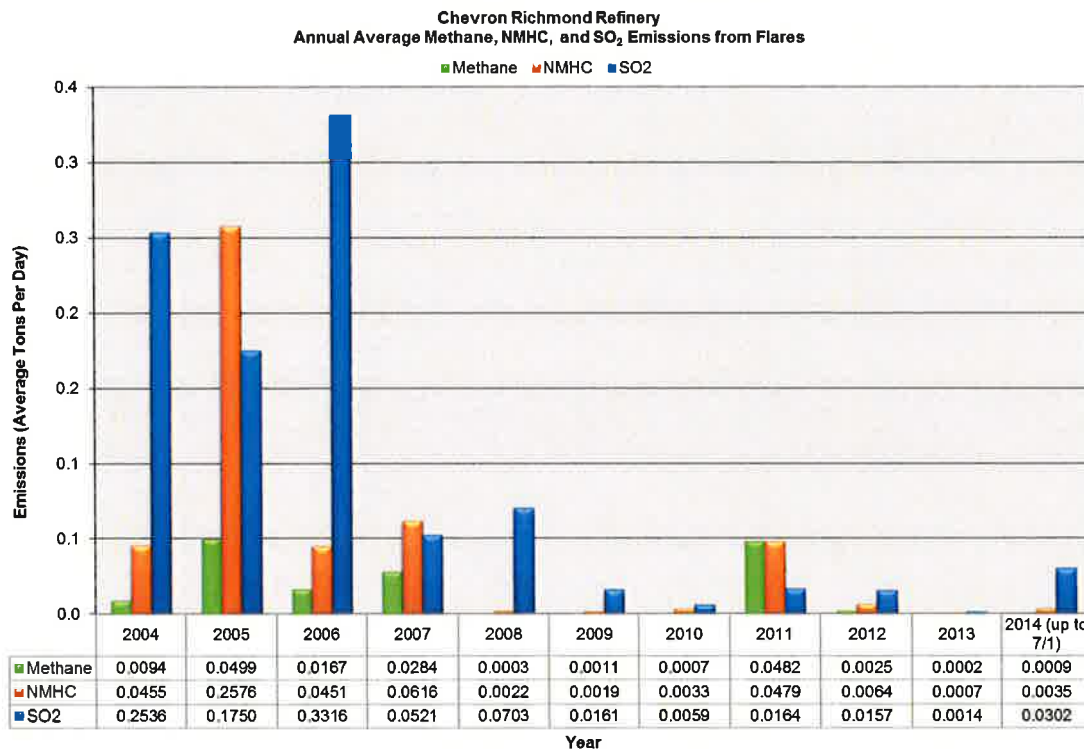

**Discussion of Flare Reductions and New or Amended Prevention Measures**

Over the past 12-months, the Refinery has managed to maintain its average flare emissions at levels well below those in 2004-2007. The Refinery has completed a variety of complex planned maintenance events with less flaring than previous events of similar scope. This continued flare performance is attributable to an ongoing, refinery-wide emphasis on minimizing flaring and additional reductions during planned maintenance activities. These flare reductions are driven by improvements in the following three primary focus areas: (1) source control program, (2) equipment and process unit reliability, and (3) planned maintenance practices.

The Refinery's source control program identifies sources contributing to the volume of gases going to the relief system that may be re-routed, mitigated or eliminated. Minimizing sources to the relief system decreases average loading on the Flare Gas Recovery (FGR) compressors, increasing FGR available capacity to be used to capture gases for emergency situations. For example, during this reporting period, sources that contribute to the FGR were identified and reduced thus increasing the available capacity of FGR compressors.

A key aspect in the operation of the Refinery is a refinery-wide program that focuses on the reliability of equipment and process units. Investments in equipment reliability directly contribute to flare minimization. For example, during this period, source control efforts have identified several valves in the process units that were leaking process gas into the South Yard (SY) relief system and required maintenance. Maintenance was conducted on these valves in order to ensure their reliable operation and minimized the contributions to the SY flare gas compressors.

Historically, planned maintenance events accounted for a substantial portion of Richmond's flaring activity. As a result, a variety of enhancements have been made to the Refinery's



practices for relief system management during planned maintenance. Examples are: (1) using temporary condensing equipment to decrease the impact of steaming equipment to relief and (2) staggering the vessel depressurizing schedule to minimize load on the relief system. In addition, planned maintenance scopes of work are evaluated for opportunities to minimize the potential for flaring and a project "flare plan" is created. Where feasible, schedules of the maintenance activities are adjusted so that the potential to flare is minimized. For example, during this period, the Refinery has dedicated engineering resources to ensure any upcoming major maintenance event is prepared to minimize and, at times, eliminate flaring by altering the scheduled depressuring of process vessels.

In addition to these proactive elements of the Refinery's flare minimization program, Operations' approach in responding to equipment malfunctions and unplanned shutdowns is having a positive impact on the reduction of flaring. The emergency procedures and Operations' responses to unplanned situations include a focus on the impact to the relief system and how to take the necessary operational actions, while maximizing relief gas recovery and consequently minimizing flaring. In some cases, flaring cannot be avoided during an emergency situation and the flares are used to protect the safety of equipment, personnel, and the environment. Added flexibility in the Refinery's relief gas recovery system, including dual service compressors that can support the relief system when needed, provides Operations with more flexibility when responding to emergency situations. Lastly, Chevron identifies all flaring activities for the purpose of reporting vent gas volume and emissions in accordance Regulation 12, Rule 11. For flare activities below BAAQMD thresholds that would trigger causal analysis, Chevron continues to identify the cause(s) for all flare activities and implement lessons learned that can improve flare minimization efforts and overall flare performance.

The following updated Flare Minimization Plan will identify additional measures planned during the next FMP Year that will continue to support the Refinery's efforts to reduce flaring and sustain success.

## 1.0 Introduction

This Flare Minimization Plan (FMP) for the Chevron Richmond Refinery (the “Richmond Refinery”) is provided pursuant to the requirements of Regulation 12, Rule 12 (Reg. 12-12), which was adopted by the Bay Area Air Quality Management District (BAAQMD) on July 20, 2005. The FMP defines a series of measures intended to reduce flaring to the extent that is feasible without compromising safety and necessary refinery operations and practices. It is the Richmond Refinery’s policy that flaring events will only occur within the scope of Reg. 12-12, and that we will adjust the operation of process units to prevent flaring when consistent with safe and reliable operations.

Reg. 12-12 prohibits flaring “unless it is consistent with an approved FMP and all commitments under that plan have been met.” BAAQMD 12-12-301. For purposes of this regulation, flaring is defined as “the combustion of vent gas in a flare,” see Reg. 12-12-203, and “vent gas” is defined as “any gas directed to a flare excluding assisting air or steam, flare pilot gas, and any continuous purge gases,” see Reg. 12-12-213. The FMP does not apply to flaring that the APCO determines to be “caused by an emergency and is necessary to prevent an accident, hazard or release of vent gas directly to the atmosphere.” Reg. 12-12-301.

The key approaches used to reduce flaring include planning efforts focused at flare minimization coupled with evaluation of the causes of flaring events that do occur and implementing corrective actions from those events. By using this approach and having an understanding of the causes of flaring events, we can incorporate the lessons learned into future planning and flare minimization efforts. The FMP also examines the costs and benefits of potential equipment modifications to increase flare gas recovery.

### 1.1 Background Information on Flare Systems

The following section describes how gases are generated and handled by refinery flare systems. A simplified schematic of a refinery flare system with flare gas recovery is shown in Figure 1-1.

Figure 1-1, Simple Schematic - Flare System with Flare Gas Recovery

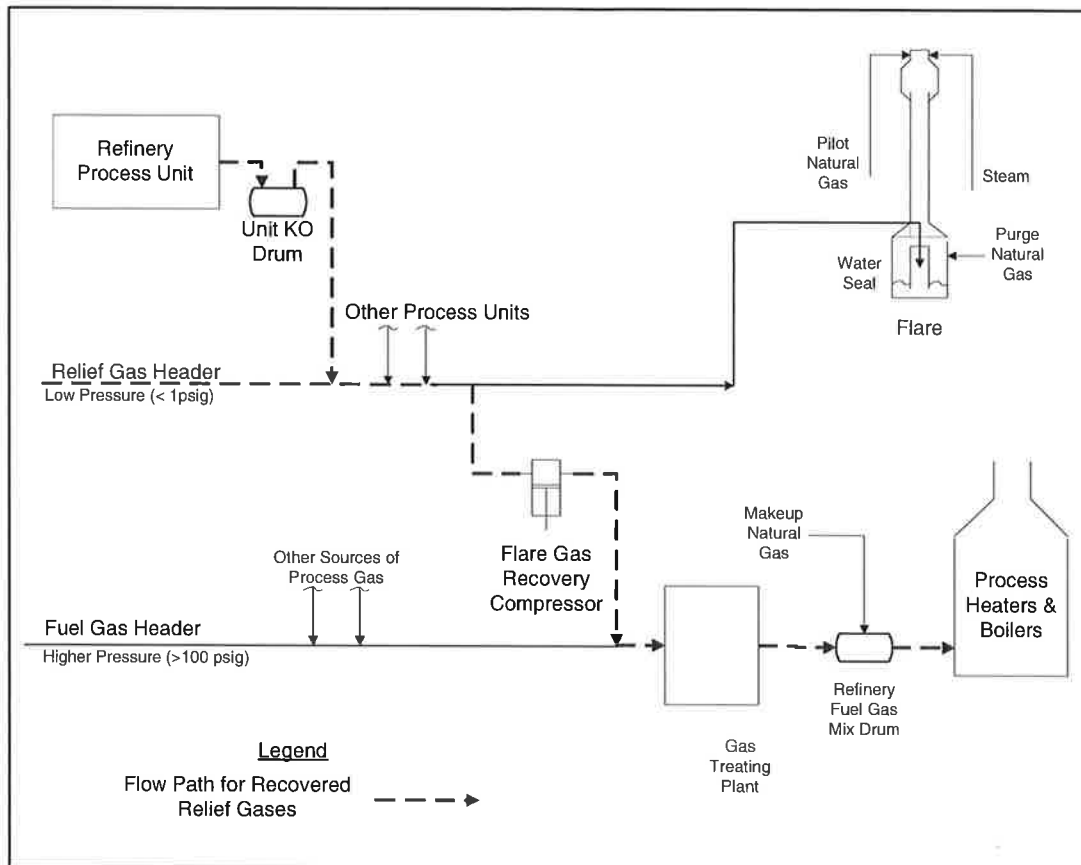

Refineries process crude oil by separating it into a range of components, or fractions, and then processing those components to produce a planned yield of desired refined products. Petroleum fractions include heavy oils and residual materials used to make fuel oil, mid-range materials such as diesel, jet fuel and gasoline, and lighter products such as butane, propane, and fuel gases.

A typical refinery is organized into groups of process units, with the general goal of maximizing the production of transportation fuels – gasoline range materials in the summer; distillate (jet and diesel) range materials in the winter. Each unit takes in a set of feed streams and produces a set of product streams with the composition changed (or upgraded) as one step toward production of an optimal mix of refined products. Many of these processes operate at elevated temperatures and pressures, and a critical element of safe design is having the capability of releasing excess pressure via relieving devices to the relief gas header to return processes to a safe posture in a controlled manner. These separation and rearrangement processes also produce and/or consume materials that are gases at atmospheric pressure. As a final step in processing, many units provide treatment to conform to environmental specifications such as reduced sulfur levels.

Refineries are designed and operated so that there will be an optimum balance between the rates of gas production and consumption. Under normal operations, gases that are not recovered as products (predominantly methane, ethane, and hydrogen) are routed to the refinery fuel gas system, allowing them to be used for combustion in refinery heaters and boilers. Typical refinery fuel gas systems are configured so that the fuel gas pressure is maintained by making up with purchased natural gas to meet the net fuel requirement. This provides a simple way to keep the system in balance so long as gas needs exceed the volume

of gaseous products produced. Some additional operational flexibility is typically maintained by having the ability to burn other fuels such as propane or butane, and having the capability to adjust the rate of fuel gas consumption to a limited extent at the various refinery users (e.g., heaters, boilers, cogeneration units, steam turbines).

A header for collection of vapor streams is included as an essential element of nearly every refinery process unit. At the Richmond Refinery, these are typically referred to as "relief gas headers", since the system, which is generally at near-atmospheric pressure conditions, receives gases "relieved" from higher pressure operations within the unit. The primary function of the relief gas header is safety. It provides the process unit with a readily available and controlled means of releasing gases to prevent over-pressurization of equipment (routing them to controlled locations for destruction by combustion). It also provides a controlled outlet for any excess vapor flow, nearly all of which is flammable, making it an essential safety feature of every refinery. Each relief gas header has connections for equipment depressurization and purging related to maintenance turnaround, startup, and shutdown, as well as pressure relief devices and other safety control valves to handle upsets, malfunctions, and emergency releases.

It is common practice for the process unit's relief gas header to incorporate a knockout drum for separation of entrained liquid at the unit boundary. This minimizes the possibility of liquid being carried forward to the flare or flare gas compressor. Liquids cause serious damage to most types of compressors and cannot be safely and completely burned in a flare. Liquids (condensed water and any entrained hydrocarbon liquids) from the unit knockout drum are sent to sour water handling facilities. The vapor stream from the knockout drum is routed to a flare gas recovery system.

A typical refinery flare system consists of a series of branch lines from various unit collection systems which join a main relief gas header. The main relief gas header is, in turn, connected to both a flare gas recovery system and to one or more flares. Normally all vapor flow to the relief gas header is recovered by flare gas recovery compressors, which increases the pressure of the flare gas allowing it to be first routed to a gas treater for removal of contaminants such as sulfur and then delivered to the refinery fuel gas system. Gas in excess of what can be handled by the flare gas recovery compressor(s), the treater(s), and/or the fuel gas system end users is directed to a refinery flare so it can be safely combusted.

A flare water seal is located in the bottom of each flare to serve several functions. The flare seal is a dam of water that is maintained in the bottom of the flare to create a barrier through which the gas must cross in order to go out of the flare stack. The depth of liquid maintained in the seal determines the pressure that the gas must reach in the relief gas header before it can exit the flare. The flare seal creates a positive barrier between the header and the flare, ensuring that gas from the relief gas header will not go to the flare if the flare gas recovery system can keep pace with the net gas production. It also guarantees a positive pressure at all points along the relief gas header, eliminating the possibility of air leakage into the system. Finally it provides a positive seal to isolate the top of the flare, which is an ignition source, from the relief gas header and the process units. Some flare systems combine multiple flares with a range of water seal depths, effectively "staging" operation of the various flares. At the Richmond Refinery, such staging is configured to favor the recovery of relief gases with the highest sulfur concentrations so that the first gases flared would be those lower in sulfur content.

A flare molecular seal is located at the top of each flare near the flare tip and is designed to minimize the amount of purge gas sent to the flare. Purge gas is used to prevent oxygen from entering the flare and creating a safety issue. Like a water seal, the molecular seal serves to

protect the stack from flame front or flash back. Molecular seals work based on the difference between the density of the air and hydrocarbon mixture.

Gases exit the flare via a tip, which is designed to promote proper combustion over a range of gas flow rates. Steam is used to increase mixing between air and hydrocarbon vapors at the flare tip, so as to improve the efficiency of combustion and reduce smoking. The combustion efficiency for steam-assisted flares is high even when some smoking is present – generally over 97% according to some references. A continuous flow of natural gas to the flare is required for two reasons. Natural gas pilot flames are kept burning at all times at the flare tip to ignite any gas exiting the flare. Additionally, a small flow of “purge” gas is required to maintain a positive upwards flow and prevent air from being sucked back into the flare stack where it could create an explosive environment. Purge gas is generally either nitrogen (an inert gas) or an easily combusted gas – the Richmond Refinery uses natural gas for its purge flows.

The sources of normal or base level flow to a refinery flare gas collection system are varied, generally small contributions, and include sources such as: leaking relief valves awaiting maintenance, instrument purges, and pressure control for refinery equipment items (e.g., overhead systems for distillation columns). Added to this low level base load are small spikes in flow from routine maintenance operations, such as clearing hydrocarbon from a pump or filter by displacing volatiles to the relief gas header with nitrogen or steam, or blowing down knockout drums. Additional flare load results from routine process functions, often related to operation of batch or semi-batch operations.

Maintenance activities can also result in higher than normal flow of material to the relief system. Maintenance activities require removing (purging) all hydrocarbon from process equipment, associated piping, and catalyst loads. This is done to address employee and equipment safety concerns, and for environmental compliance. Procedures to prepare for maintenance include multiple steps of depressurization, and purging with nitrogen or steam to the relief gas header. Efforts are made to recover as much relief gas as technically possible. However, because of sound engineering principles, it is not always feasible to recover 100% of the relief gas generated. For example, gases such as nitrogen with higher heats of compression can cause overheating, resulting in damage to flare gas recovery compressor parts. Nitrogen would also lower the heating value of refinery fuel gas and greatly affect performance of fired process heaters throughout the refinery.

Although maintenance-related flows can be large, the design and sizing of refinery flare systems is driven by the need for safe and controlled destruction and release of much larger quantities of gases during upsets and emergencies. The flare system is designed to handle excess gases in the event of a safety related rapid depressurization. The flow that the flare system could be called upon to handle during an event of this type is several orders of magnitude greater than baseline flow rates into the relief system. A major emergency event will require the safe disposal of a very large quantity of gas and hydrocarbon materials during a very short period of time in order to prevent a potentially catastrophic increase in system pressure. Flares are used to safely and properly incinerate gases that accumulate in process equipment during emergencies. As a consequence, flaring also prevents hydrocarbons and waste gases from being released to the atmosphere. Additionally, flaring is a sound engineering practice since it prevents injuries to employees, equipment, etc.

Flares are first and foremost safety devices intended to prevent emissions of air contaminants directly to atmosphere and/or catastrophic events, both of which would have serious, adverse effects on air quality, as well as the health and safety of refinery workers and surrounding communities. Refineries have a general duty to maintain the safe and reliable operation of flares and flare systems. These systems must be continuously capable of collecting and safely combusting hydrocarbons from pressure-relieving and vapor depressurizing units throughout all

startup, shutdown, upset, or malfunction conditions. Most major flare maintenance activities necessarily must occur during a turnaround. Other maintenance activities, including preventative maintenance activities, occur while the flares and flare systems are in service. Operations routinely monitor pilot and purge, steam assist, water flow to the flare water seal, water seal integrity (see Section 2.3.2), water seal overflow, and level transmitters. Liquid hydrocarbons that become trapped in the molecular seal or that accumulate in the water seal can impair system integrity and can create safety hazards. Steam is injected, as appropriate, to remove hydrocarbon liquids and other obstructions from these seals and ancillary equipment, consistent with flare manufacturer recommendations and API/ANSI Standard 521.

## 1.2 Trade Secret Information

Appendices A, B, C, and D to this FMP contain refinery-confidential information and are trade secrets of Chevron Products Company (Chevron), as defined by the California Public Records Act, Government Code Section 6254.7 et seq., and 40 CFR Part 2, Subpart B, 18 USC 1905 and 5 USC 552(b)(4). Because of the sensitive and competitive nature of the information, Chevron Products Company requests that the BAAQMD afford the information Confidential Business Information treatment indefinitely. The content of Appendices A, B, C, and D in the public version of this FMP have been blocked out. Full copies of Appendices A, B, C, and D will be included in a Trade Secret transmittal of the FMP, provided under separate cover.

## 2.0 Technical Data

Pursuant to the requirements of Regulation 12, Rule 12, Section 401.1, the following section provides descriptions and technical information for the flare systems as well as the upstream equipment and processes that send gas to the flare at the Richmond Refinery.

### 2.1 Description of Flaring Systems

The Richmond Refinery operates two main flare systems, one covering the North Yard of the refinery, and the other covering the South Yard. Simplified Flow Diagrams for each of these systems are listed in the following Table 2-1, and are included in Appendix A to this document.

**Table 2-1 Flare System Drawings** (refer to Appendix A)

<i>Drawing No.</i>	<i>Drawing Version</i>	<i>Drawing Title</i>
NY-1	September 25, 2014	North Yard Relief System
SY-1	December 28, 2011	South Yard Relief System

#### North Yard

The North Yard flare system has a Flare Gas Recovery (FGR) system designed to recover all of the relief gases. If the flare gas compressors become fully loaded (e.g., due to a process upset), the North Yard flares can be preferentially diverted away from FGR in order to recover the streams with the highest sulfur content and; therefore, minimize sulfur compound emissions. Flare water seal heights are set to allow this staggered flare operation. The North Yard flares are staggered in the following priority:

- FCC - 18" water height The FCC and Alky-Poly flares are connected by a 36" relief line. The Alky-Poly flare, with 20" water seal height, sees flow only after the relief line pressure overcomes its water seal. The FCC Flare is set to relieve first with the Alky-Poly Flare set to relieve second. Based upon their respective location in the staged system, the FCC Flare

would be expected to receive relief gasses with lower sulfur content. The Alky-Poly flare would be expected to receive relieve gasses with higher sulfur content.

- South Isomax - 24" water seal height
- North Isomax - 24" water seal height
- RLOP - 24" water seal height

This order corresponds to flares that handle streams with increasing sulfur content, note, this preferential selection is different from cascading multiple flares on the same header. Individual flare capacity is not affected by this, as maximum flow at the flare tip for the power failure case is the same whether individual or multiple flares are operating. Episodic events and plant cleanups that require relief through the individual flares would preclude the option to preferentially select the flares.

The North Yard has three compressors available for dedicated flare gas recovery service. Compressors K-1060 and K-1070 each have a recovery capacity of 4 MMSCFD at 100% loading. K-1960 takes load off the North Yard Flare Gas Recovery (FGR) system by recovering vented hydrocarbons from the RLOP units, handling 1.3 MMSCFD of gas.

Since overhauls and upgrades to K-1060 and K-1070 were completed in January 2004, and K-1960 was re-commissioned in February 2006, reliability has been sustained on all three compressors, and preventative and proactive maintenance has been performed without causing flaring. In the event the primary compressor and K-1960 are down, either K-1060 or K-1070 therefore provides reliable, dedicated back-up with 4.0 MMSCFD capacity.

The North Yard FGR compressors K-1060 and K-1070 are manually controlled by the South Isomax operating crew. A compressor suction pressure of eight inches of water is normally targeted. The suction pressure of the FGR system controls the flare header pressure for the North Yard flares that are manifolded to the FGR system. The suction pressure is maintained by setting the valve loading at one of five fixed values: 0, 50, 57, 80 or 100% of load. Compressor discharge gas temperature is alarmed at 325 Deg F to prevent compressor damage.

RLOP Vent Gas compressor K-1960 uses four controllers to control suction at atmospheric pressure. K-1960 is loaded and unloaded using logic. This allows loading at one of five fixed values: 0, 20, 45, 75 or 100% of load. K-1960 has a recovery capacity of 1.29 MMSCFD at 100% loading and will normally run 100% loaded. Additionally, K-1960 can also be loaded and unloaded manually.

K-1060 and K-1070 have permanent sensors mounted which provide monitoring and trending of vibration and compressor performance. All FGR Compressors are also monitored, at a minimum, on a weekly basis and on an increased frequency if the parameters monitored indicate that more frequent monitoring is needed. The frequency of increased monitoring is contingent upon the unit data and history.

Either K-1060 or K-1070 compressor can serve as a spare, and schedules for preventive maintenance (PM) work are based on monitoring data. K-1960 is spared by either K-1060 or K-1070 and PM is based on monitoring data.

### South Yard

The South Yard has two flares, the LSFO Flare and the D&R Flare, connected by a common header. The water seals heights are staggered so that the LSFO Flare should relieve first and the D&R Flare relieves second. The relief system is connected to flare gas recovery as described below.

The South Yard has five compressors available for flare gas recovery service, a dedicated K-3950 plus dual service, process/FGR, compressors, K-1171/K-1171A and K-242/K-252.

The K-3950 South Yard FGR compressor is manually controlled by the D&R East operating crew and services the LSFO and D&R flares. K-3950 has a recovery capacity of 2.35 MMSCFD at 100% loading. The compressor suction pressure is maintained at 7.0 inches water pressure by setting the compressor valves at one of four fixed values: 0, 50, 75 or 100%. The loading can be adjusted locally or remotely from the operator control room. The maximum cylinder discharge temperature is alarmed at 325 deg F. to prevent compressor damage. Compressors K-1171 and K-1171A, at # 4 Crude Unit, are dual-purpose compressors of 1.7 MSCFD capacity each. The primary purpose of K-1171 and K-1171A is to provide pressure control for C-1160 and C-1190 Naphtha Stabilizers in the Crude Unit. Compressors K-1171 and K-1171A can be individually or simultaneously run because they are dual FGR/process service, in order to supplement or spare K-3950 (if K-3950 FGR compressor output is down or limited). The typical annual loading on these compressors is 1.64 MSCFD (or <50% of available capacity). They have a maximum discharge gas temperature of 250 deg F to prevent compressor damage.

K-242 and K-252 compressors were converted for dual process/FGR service in December 2007 to provide additional flare gas recovery capacity in the South Yard. These conversions provide additional and dedicated flare gas recovery compressor capacity as well as reduce the dependency on the dual role K-1171 and K-1171A compressors. K-242 and K-252 compressors are Worthington two-stage, reciprocating units with a capacity of between 1.9 and 2.3 MMSCFD per compressor, depending on the molecular weight of the gas. Either K-242 or K-252 compressor is available for back-up FGR service (with the other compressor in dual process/FGR service).

K-242/K-252 provide approximately 2.3 MMSCFD dedicated back-up capacity to the existing flare gas recovery capacity of 3 MMSCFD provided by K-3950. With an additional 1.7 MMSCFD available from each of the dual service K-1171 or K-1171A, a total of 7 MMSCFD flare gas recovery capacity is provided against the current base load of 0.8 MMSCFD.

A review of compressor availability from 2003 forward indicates that at least three of the five compressors (K-3950/K-1171/K-1171A, and K-242/K-252) were available for FGR service at all times. The upgrades to K-3950, the availability of K-1171 or K-1171A and the conversion of K-242 and K-252 (see Table 4.1, Planned Improvements) are designed to provide reliable, dedicated and flexible spare capacity.

South Yard Flare Gas Recovery (FGR) Compressor K-3950 had internal upgrades completed in January 2007 to improve its flexibility in handling nitrogen. These included valves with a wider port and larger valve area, and an upgrading to the sealing plates from steel to an engineered plastic. The ammonium salting issue with K-3950 had been resolved after the installation of two carbon drums on the bulk storage perchloroethylene drum off gas line in August, 2007. These upgrades, and the conversion of K-242 and K-252, are designed to provide reliable, dedicated spare capacity.



Schedules for preventive maintenance (PM) work on the K-3950, K-1171/K-1171A and K-242/K-252 are based on monitoring data.

For both North Yard and South Yard FGR systems, if the overall FGR load approaches the capacity of the operating compressor, indication is provided by increasing relief header pressure, which will alarm prior to flaring. If the load increases, or a primary compressor shuts down, the back-up compressor is manually started by field personnel. Once it is confirmed that the back-up compressor is operating, the board operator can load the spare compressor up to 100%. If a primary compressor has shut down, flaring would occur until the spare compressor picks up the full FGR load.

The spare North Yard FGR compressor, either K-1060 or K-1070, is kept on "hot standby". This means that the valving is in position, lube oil and cooling water to jackets are circulating, and steam tracing and nitrogen purge are operating.

For the South Yard FGR compressors, the spare of either K-1171 or K-1171A is kept in the same "hot standby" mode. In certain instances a valve has to be switched in the field. Compressors K-242 and K-252 are operated in the same way. The spare of either K-242 or K-252 is kept on "hot standby" mode and a valve needs to be switched in the field.

This mode of operation allows the spare compressor to be available and fully loaded within a few minutes if the primary compressor is impacted or unavailable. This mode supports reliable operation through having planned preventative maintenance based on monitoring data for the running compressors, and ensuring that the spare compressor is available when needed.

Running the spare FGR compressor on a continual basis would unnecessarily increase operating run time on two machines to recover the same amount of gas. This would increase the risk that a compressor will not be available (due to preventative maintenance servicing / breakdown) when it is needed.

Compressors operate within specific parameters (or operating envelopes). When process flows are at the limits of the compressors operating envelope, additional control measures have to be introduced to maintain reliable process conditions and mechanical integrity. These measures introduce an additional level of complexity to the operation that is not present when one compressor is operating to adequately handle the load.

Having the standby compressor on "hot standby" ensures that if an event takes place that negatively impacts the on-line compressor, then the standby compressor is not exposed to the same adverse conditions and is therefore likely to be available for a quick response if needed.

Operating two compressors in parallel would also waste considerable energy, as these compressors are driven by large motors. K-3950 is driven by a 500 horsepower (HP) motor. K-1060 and K-1070 are driven by 700 HP motors and K-242 / K-252 by 800 HP motors.

During normal flare gas recovery conditions, the loss of the primary flare gas recovery compressor will not necessarily lead to flaring. Flare header pressure operates at slightly above atmospheric pressure, while the water seals on the flares are set at 18" Water Gauge or higher. There is, therefore, a period of time (the duration cannot be defined as it will vary depending on the conditions at the time) before the system pressure in the flare gas recovery header exceeds the water seal pressure, which allows for a period of time in order to start the standby compressor.

The current effective and reliable operation requires having a spare compressor. There is no benefit to run the spare compressors as long as the FGR load does not exceed the capacity of the current FGR compressors.

The North Yard Flare System is connected to relief systems from process units located in the Cracking, Hydro-processing and RLOP (Richmond Lube Oil Project) divisions. There are five active Flares in the North Yard Flare System. These flares, and the process units associated with each, are listed in Table 2-2.

**Table 2-2 North Yard Flare System Plant Sources**

<i>BAAQMD Flare No.</i>	<i>Flare Name</i>	<i>Process Units</i>
S-6016	FCC (Note 1)	S-4285, Fluidized Catalytic Cracking Plant (FCC) S-4286, FCC Gas Recovery Unit (FCC GRU) S-4433, 3H2S
S-6019	Alky-Poly (Note 1)	S-4291, H2SO4 Alkylation Plant (Alky) S-4292, Propylene Polymer Plant (Poly) S-4354, Butamer Plant S-4355, Deisobutanizer Plant (Yard DIB) S-6050, MTBE Plant S-4356, TAME Plant S-4227, Sulfur Recovery Unit (SRU) #1 S-4228, Sulfur Recovery Unit (SRU) #2 S-4229, Sulfur Recovery Unit (SRU) #3
S-6039	RLOP	S-4340, Light Neutral Hydrocracker (LNC) S-4341, Light Neutral Hydrofinisher (LNHF) S-4342, Heavy Neutral Hydrocracker (HNC) S-4343, Heavy Neutral Hydrofinisher (HNHF) S-4346, RLOP Gas Recovery Unit (RLOP GRU) S-4345, #18 NH3-H2S Plant S-4454, #6 H2S Plant - Amine Regenerator
S-6013	NISO	S-4252, TKN/Isocracker Plant (TKN/ISO) S4253, TKC Plant S-4429, #8 NH3-H2S Plant S-4434, #4H2S
S-6012	SISO	S-4348, #20 Plant - Hydrogen Recovery S-4250, Hydrogen Manufacturing Plant S-4251, Solvent Deasphalting Plant (SDA) S-4238, LPG Loading Racks (LPG Racks)

Note 1: The FCC and Alky-Poly Flares are linked in a cascade. FCC is the primary flare; Alky-Poly is secondary.

The South Yard Flare System is connected to relief systems from process units located in the Distillation & Reforming (D&R) Area Business Unit (ABU), the Utilities & Environmental (U&E) ABU and the Blending & Shipping (B&S) ABU. There are two flares connected to the South Yard system. These flares, and the process units associated with them, are listed in Table 2-3.

**Table 2-3 South Yard Flare System Plant Sources**

<i>BAAQMD Flare No.</i>	<i>Flare Name</i>	<i>Process Units</i>
S-6010	LSFO	S-4226, FCC Gas Hydrotreater (FCC GHT) S-4233, Jet Hydrotreater (JHT) S-4234, #5 Naphtha Hydrotreater (5NHT) S-4235, Diesel Hydrotreater (DHT) S-4236, #4 Crude Unit (4CU) S-4282, Penhex Isomerization Unit (Penhex) S-4283, #4 Rheniformer (4CAT) S-4237, #5 Rheniformer (5CAT) S-4435, #5 H2S Plant (5H2S) Cogeneration Plant Sources Utilities Plant Sources
S-6015	D&R	S-4226, FCC Gas Hydrotreater (FCC GHT) S-4233, Jet Hydrotreater (JHT) S-4234, #5 Naphtha Hydrotreater (5NHT) S-4235, Diesel Hydrotreater (DHT) S-4236, #4 Crude Unit (4CU) S-4282, Penhex Isomerization Unit (Penhex) S-4283, #4 Rheniformer (4CAT) S-4237, #5 Rheniformer (5CAT) S-4435, #5 H2S Plant (5H2S) Cogeneration Plant Sources Utilities Plant Sources

## 2.2 Detailed Diagrams for Flaring Systems

Table 2-4 provides a list of Piping & Instrumentation Diagrams (P&IDs) for each of the refinery's currently regulated flares. Copies of the P&IDs are located in Appendix B to this document.

**Table 2-4 Flare P&IDs (refer to Appendix B)**

<i>Drawing No.</i>	<i>Drawing Version</i>	<i>Flare or Flare System</i>
D-320896	Revision 20 (issued 12/30/2010)	Alky-Poly Flare (S-6019)
D-320897	Revision 20 (issued 09/22/2014)	FCC Flare (S-6016)
D-324793	Revision 22 (issued 07/14/2014)	NISO Flare (S-6013)
D-324787	Revision 31 (issued 05/01/2012)	RLOP Flare (S-6039)
D-313651	Revision 20 (issued 04/18/2013)	LSFO Flare (S-6010)
D-324795	Revision 22 (issued 07/14/2014)	SISO Flare (S-6012)
D-329038	Revision 15 (issued 07/14/2013)	D&R Flare (S-6015)
D-368506	Revision 1 (issued 04/17/2013)	D&R Flare (S-6015)
D-368375	Revision 1 (issued 04/15/2013)	D&R Flare (S-6015)

Table 2-5 provides a list of mechanical elevation drawings for each currently regulated flare. Copies of the drawings are located in Appendix C to this document.

**Table 2-5 Flare Elevation Drawings** (refer to Appendix C)

<i>Chevron Drawing No. (Vendor No., if other)</i>	<i>Drawing Version</i>	<i>Flare or Flare System</i>
146216-2-F-2 (259-A-EWS-1)	Revision 1	FCC Flare (S-6016)
14216-2-F-2 (262-A-EWS-1)	Revision 3	Alky-Poly Flare (S-6019)
14216-2-F-4 (301-A-EWS-1)	Revision 2	RLOP Flare (S-6139)
14216-2-F-2 (244-A-EWS-1)	Revision 4	NISO Flare (S-6013)
FP-202318-0 (F92-0726-301)	Revision 2	SISO Flare (S-6012)
A-160960-8	Revision 8	SISO Flare (S-6012)
10640-2-F-40 (B-F-069761-302)	Revision 3	LSFO Flare (S-6010)
D-229930-0	Revision 0	LSFO Flare (S-6010)
D-228265-0	Revision 0	LSFO Flare (S-6010)
FP-207308 (B-F-913483-202)	Revision 6	D&R Flare (S-6015)

## 2.3 Monitoring and Control Equipment

### 2.3.1 Flare Gas Flow Monitoring

As required by BAAQMD Regulation 12 Rule 11, Section 501, all of the refinery's current active flares are equipped with continuous flare vent gas flow meters. The flow meters used for this monitoring are listed in Table 2-6 and contain multiple outputs as shown.

**Table 2-6 Flare System Flowmeters**

<i>Tag Numbers</i>	<i>Name &amp; Location</i>	<i>Type</i>	<i>Ranges</i>
59FI735 59PI735 59TI735 59AI735	<u>FCC Flare vent gas flowmeter</u> Installed on Cracking Area relief line, between connection to North Yard FGR System and inlet to FCC Flare (S-6016). P&ID D-320897	gas ultrasonic flowmeter	0 to 355 MMSCFD 13.8 to 20.1 PSIA 0 to 300 F 0 to 60 Gram/mol
59FI736 59PI736 59TI736 59AI736	<u>Alky-Poly Flare vent gas flowmeter</u> Installed on Cracking Area relief line, between connection to FCC flare vent gas line and inlet to	gas ultrasonic flowmeter	0 to 185 MMSCFD 13.8 to 20.1 PSIA 0 to 300 F 0 to 60 Gram/mol

<i>Tag Numbers</i>	<i>Name &amp; Location</i>	<i>Type</i>	<i>Ranges</i>
	Alky-Poly Flare (S-6019). P&ID D-320896		
80FI110 80PI110 80TI110 80AI110	<u>RLOP Flare vent gas flowmeter</u> Installed on RLOP Area relief line, between connection to North Yard FGR System and inlet to RLOP Flare (S-6039). P&ID D-324787	gas ultrasonic flowmeter	0 to 180 MMSCFD 13.8 to 20.1 PSIA 0 to 500 F 0 to 50 Gram/mol
69FI287 69PI287 69TI287 69AI287	<u>NISO Flare vent gas flowmeter</u> Installed on North Isomax Area relief line, between connection to North Yard FGR System and inlet to NISO Flare (S-6013). P&ID D-324793	gas ultrasonic flowmeter	0 to 100 MMSCFD 13.8 to 20.1 PSIA 0 to 300 F 0 to 100 Gram/mol
69FI286 69PI286 69TI286 69AI286	<u>SISO Flare vent gas flowmeter</u> Installed on South Isomax Area relief line, between connection to North Yard FGR System and inlet to SISO Flare (S-6012). P&ID D-324795	gas ultrasonic flowmeter	0 to 60 MMSCFD 13.8 to 20.1 PSIA 0 to 500 F 0 to 60 Gram/mol
39FI002 39PI002 39TI002 39AI002	<u>LSFO Flare vent gas flowmeter</u> Installed on D&R ABU relief line, between connection to South Yard FGR System and inlet to LSFO Flare (S-6010). P&ID D-313651	gas ultrasonic flowmeter	0 to 185 MMSCFD 13.8 to 20.1 PSIA 0 to 300 F 0 to 60 Gram/mol
39FI030 39PI030 39TI030 39AI030	<u>D&amp;R Flare vent gas flowmeter</u> Installed on D&R ABU relief line, between connection to South Yard FGR System and inlet to D&R Flare (S-6015). P&ID D-368506	gas ultrasonic flowmeter	0 to 300 MMSCFD 13.8 to 30.9 PSIA 0 to 800 F 2 to 120 Gram/mol

### 2.3.2 Water Seal Integrity & Pressure Monitoring

As required by BAAQMD Regulation 12, Rule 12, Section 501, “the owner or operator of a flare subject to this rule with a water seal shall continuously monitor and record the water level and pressure of the water seal that services each flare.” The North Yard and South Yard flares are each equipped with a water seal. The refinery maintains and operates instrumentation to continuously monitor and record the flare header pressure and the water seal liquid level for each flare. The integrity of each water seal is ensured during any period where the liquid level in the water seal, measured in units of inches of water by a liquid level transmitter, exceeds the flare header pressure, measured in terms of inches of water by a pressure transmitter. A “reportable flaring event,” as defined in Reg. 12-12-208, ends “when it can be demonstrated by monitoring required in Section 12-12-501 that the integrity of the water seal has been maintained sufficiently to prevent vent gas to the flare tip.” Flaring, as defined in Reg. 12-12-203, can only occur when the integrity of the water seal has been compromised, as indicated

when the flare header pressure in terms of inches of water exceeds the water seal liquid level (inches). The liquid level and pressure transmitters used for flare relief header pressure and water seal liquid level monitoring are listed in Table 2-7.

Liquid Level Monitoring – The water seals on the North Yard flares are replenished on continuous overflow using stripped sour water supplied from the stripped water tank T-3340. Each water seal is equipped with a continuous overflow of water. The system is designed in keeping with manufacturer recommendations to remove or “skim” hydrocarbons off the top of the water seal. Liquid hydrocarbons in the seal can inhibit the accuracy of liquid level transmitters and can create unsafe conditions during flaring events. Spent water then gravity feeds to V-283 rundown vessel for the North Yard flare water seals. V-283 is maintained at atmospheric pressure, with an equalization line between V-283 and the North Isomax flare stack. Any hydrocarbon compounds that could be present in V-283 are from flare rundown and therefore would have already been monitored by one of the five North Yard flare meters. The South Yard flares water seals are replenished using fresh water via an automated level control valve to maintain the designated seal level. Spent water is then routed to the water-oil separator. Water seal liquid level transmitters for currently active flares in the North Yard and South Yard are calibrated to read “0 inches” at the water level equivalent to zero effective inches of water seal.

Pressure Monitoring – The relief header pressure is measured by pressure transmitters associated with the ultrasonic flow meter installations described in Section 2.3.1. Relief header pressure and temperature are used to convert actual flow rate measurement to engineering unit flow rates at standard temperature and pressure. The relief header pressure transmitters are located in the flare vent gas lines upstream of each flare connection to provide a measurement of the gauge line pressure (relative to atmospheric pressure) on the vent gas line side of the water seal.

**Table 2-7 Water Seal Level Indicators and Flare Vent Gas Pressure**

<i>Tag Number</i>	<i>Instrument (P&amp;ID #)</i>	<i>Instrument Type</i>	<i>Range</i>
59LI731A	FCC Flare water seal level height, in inches P&ID D-320897	Differential Pressure Level Transmitter	-10 to +43 inches water column
59PI735	FCC Flare vent gas pressure P&ID D-320897	Honeywell Pressure Transmitter, absolute pressure	13.8 to 20.1 PSIA
59LI732A	Alky-Poly Flare water seal level indicator. P&ID D-320896	Differential Pressure Level Transmitter	-64 to +56 inches water column
59PI736	Alky-Poly Flare vent gas pressure P&ID D-320896	Honeywell Pressure Transmitter, absolute pressure	13.8 to 20.1 PSIA
80LI501A	RLOP Flare water seal level P&ID D-324787	Guided wave radar level transmitter	-5 to +62 inches water column
80PI110	RLOP Flare vent gas pressure P&ID D-324787	Honeywell Pressure Transmitter, absolute pressure	13.8 to 20.1 PSIA
69LI281A	NISO Flare water seal level indicator. P&ID D-324793.	Guided wave radar level transmitter	-7 to +72 inches water column

69PI287	NISO Flare vent gas pressure P&ID D-324793	Honeywell Pressure Transmitter, absolute pressure	13.8 to 20.1 PSIA
69LI282A	SISO Flare water seal level indicator. P&ID D-324795	Guided wave radar level transmitter	-8.5 to +56.5 inches water column
69PI286	SISO Flare vent gas pressure P&ID D-324795	Honeywell Pressure Transmitter, absolute pressure	13.8 to 20.1 PSIA
39LC003	LSFO Flare water seal level indicator. P&ID D-313651	Displacer Type Transmitter	0 to 37 inches water column
39PI002	LSFO Flare vent gas pressure P&ID D-313651	Honeywell Pressure Transmitter, absolute pressure	13.8 to 20.1 PSIA
39LC030 39LT031	D&R Flare water seal level transmitter. P&ID D-329038-14A	Displacer Type Transmitter	-25 to 450 inches water column
39PI030	D&R Flare vent gas pressure P&ID D-368506	Honeywell Pressure Transmitter, absolute pressure	13.8 to 30.9 PSIA

### 3.0 Past Reductions

Pursuant to the requirements of Regulation 12, Rule 12, Section 401.2, this section provides a description of equipment, processes or procedures that the Richmond Refinery installed or implemented to reduce flaring during the five years immediately preceding promulgation of Regulation 12, Rule 12 (on July 20, 2005). Past changes, and the year in which they were implemented, are summarized below in Table 3-1.

The listing of historical changes provided in Table 3-1 is intended as a one-time snapshot of Chevron's good faith efforts to reduce flaring prior to the implementation of Regulation 12, Rule 12. Past changes, and the year in which they were implemented, are also summarized below.

**Table 3-1 Historical Changes to Reduce Flaring**

<i>Year Installed or Implemented</i>	<i>Flare System Affected</i>	<i>Equipment Item Added, Process Changed or Procedure Implemented</i>
2000	South Yard	Started placing crude unit vent gas recovery compressors in service as FGR compressors (when K-3950 FGR compressor output is down or limited) depending on availability. Either K-1171, K-1171A, or both are put in service using a manual procedure in the field. K-1171 and K-1171A can provide 1.7MMSCFD capacity apiece in combined FGR / process service. The additional FGR capacity provided by K-1171 and K-1171A reduces flaring by increasing the ability of the South Yard FGR system to recover all relief gas when K-3950 output is down or limited. (There is no benefit to running the spare compressors as long as the FGR load does not exceed the

<i>Year Installed or Implemented</i>	<i>Flare System Affected</i>	<i>Equipment Item Added, Process Changed or Procedure Implemented</i>
		capacity of the current FGR compressors.) K-1171 and K-1171A are two-stage, Ingersoll-Rand model 2HSE2 25X14.5X9 reciprocating units.
2002	all	Shutdown Flare Planning Process implemented for planned maintenance work during plant shutdowns (i.e., turnarounds) (See section 5.1.6).
2002	South Yard	Implemented source control to reduce relief gas flows into the South Yard Flare Gas Recovery system. The source control effort was an intensive look that was undertaken to identify sources of loading to the South Yard Flare Gas Recovery system, such as valves, vents and pressure relief devices. Identifying and controlling these sources reduced the overall load on the FGR system. The likelihood of flaring was reduced because the FGR compressors would be more likely to recover all of the flare gas generated.
2002/2003	all	<p>The "Fuel Gas Load Shed" procedure worksheet was revised. This procedure provides a series of operational steps to respond to situations where the fuel gas demand begins to dip, or when fuel gas production exceeds demand, and excess relief gas generation could eventually cause flaring, by reducing the load on the FGR system. This worksheet provides a sequence of steps that reduce process gas generation and/or create more uses for fuel gases generated. The Refinery Shift Coordinator monitors natural gas makeup to the fuel gas drums. If this make-up drops, it indicates that the fuel balance is approaching the point at which more gas could be produced than could be consumed. The Fuel Gas Load Shed procedure is implemented to provide a "cushion" to avoid situations causing flaring because there is more fuel gas produced than can be consumed. Some steps are taken to reduce the load on the fuel gas system by creating more fuel gas consumers, for example as switching electric drivers to steam turbines, and increasing cold feed into units (which would require fuel gas consumption to heat up the feed). Some steps are taken to reduce the load on the fuel gas system by reducing the amount of gas generated, for example employing secondary cooling to increase heat transfer and condense more material in overhead systems; backwashing heat exchangers to increase their heat transfer, provide better cooling and reduce vent gas generation; raising process column pressures, which reduces the gas make-up required; and raising the LPG content of the gasoline streams.</p> <p>Curtailing refinery operations also reduces the load on the fuel gas system by reducing the amount of gas generated, such as stopping the offloading of LPG cars, reducing unit operating severity to reduce the amount of gas generated, and reducing unit throughputs to reduce gas make-up. This worksheet has been continually updated over the past twenty years as improvements are identified. The Fuel Gas Load Shed</p>



<i>Year Installed or Implemented</i>	<i>Flare System Affected</i>	<i>Equipment Item Added, Process Changed or Procedure Implemented</i>
		<p>procedure is employed to respond to plant conditions which could cause a fuel gas imbalance. The response to any particular event is dependent on the operating conditions at the time and the exact cause of the FGR system reaching full capacity. In different scenarios some actions are more effective than others. This is not the optimal or even desirable mode of operations in most circumstances, as overall facility efficiency is reduced and facility emissions may increase. (When shutting down plants for maintenance, fuel gas load is not the issue, as more sources of fuel gas generation than fuel gas consumers are lost, so the Fuel Gas Load Shed procedure is not needed for planned shutdowns. Flaring that occurs during the planned shutdown process is due to the inability to stay on FGR while depressuring and purging equipment, rather than any fuel gas balance issues.)</p>
2003	North Yard	<p>Temporary scrubber: A spare scrubber unit was employed during the 1Q2003 RLOP shutdown so C-890 scrubber could undergo maintenance without interruption of scrubber operation. By maintaining this scrubbing capacity, this gas stream could be recovered instead of having to be flared. The spare was removed after maintenance was completed. During normal operation there is sufficient scrubbing capacity, so portable scrubbing units are generally not required.</p>
2003 – 2005	North Yard	<p>K-1060 and K-1070 North Yard flare gas recovery compressors (Worthington, two stage, three cylinder, reciprocating) had modifications to internal parts and auxiliary systems to increase reliability and potential ability to handle gases with higher heats of compression (e.g., Nitrogen, Hydrogen). Internal modifications included material upgrades to piston parts. The internal modifications were completed in several stages, incorporating lessons learned to allow for a slight increase in operating temperature, which would enable plants to stay on FGR for a longer period of time during some clean-up operations. Modifications to auxiliary systems included adding a spare pump to the FGR compressor knockout drum to reduce the chance of the system shutdown, and adding supplemental cooling to a relief drum to enhance gas recovery. The higher discharge temperature for K-1060 and K-1070 and measures to increase reliability will directionally allow plants to remain on FGR for longer periods during shutdown purge and cleanup operations, and start-up activities.</p>
2003	North Yard	<p>Source control: Installed 15 Kurz Model 454 FT thermal convection mass flow indicators on relief lines to provide better indication of source of relief gases. The source control effort was an intensive look that was undertaken to identify sources of loading to the North Yard Flare Gas Recovery system, such as valves, vents and pressure relief devices. The flow meters were installed to help identify these sources so they could be controlled. Controlling these sources reduced the overall load on the FGR system. The likelihood of flaring was reduced</p>

<i>Year Installed or Implemented</i>	<i>Flare System Affected</i>	<i>Equipment Item Added, Process Changed or Procedure Implemented</i>
		because the FGR compressors would be more likely to recover all of the flare gas generated.
2003-2004	all	The E-1190 fogger capital project provided supplemental cooling to the overhead of the C-1190 Naphtha Stabilizer column in the Crude unit when ambient temperatures are expected to exceed 75 F. Cleaning fin fan heat exchangers for the summer months also provides greater cooling efficiency. Both of these reduce the generation of vent gases which would otherwise add to the load on the FGR systems. Reducing the load on FGR systems reduces the likelihood of flaring because the FGR compressors would be more likely to recover all of the flare gas generated. New operating procedures 4CU4765j, 4CU4770j, and 4CU4775j were implemented for operation of the E-1190 fogger. Operating procedure 4CU-NP-4780 was implemented for fin fan cleaning. These procedures are implemented when ambient temperatures are expected to exceed 75 F, as described above.
2003 - 2004	North Yard	K-400/K-500 plant recycle compressor replacement. Prior to replacing the recycle compressors, there were several unplanned shutdowns of K-400 and K-500, which in turn caused their respective TKC and TKN units to shutdown. Unplanned unit shutdowns required rapid depressuring of equipment which caused flaring. Replacing the recycle compressors improved their reliability, thereby avoiding unplanned shutdowns and flaring.
September 2007	Both	Flare source and meter database: Databases and tools have been developed to track sources by business locations, operation activities (shutdowns), valve types, and by dates when leaks are identified and fixed. They can also assist operation staff to make any necessary operational moves to minimize potential flaring.
July to December 2007	Both	Multiple training sessions were conducted with operation staff to communicate the requirement of the FMP.
December, 2007	South Yard	A new ¾" bypass valve was installed at Cogen's LPG knock-out drum in addition to its original 2" valve to enhance the control of blowdown rate.
January, 2008	Both	All drain and vent valves routed to FGR systems were labeled to advise caution while being operated. Identifying all valved sources to FGR systems will reduce loading on FGR compressors.
DHT Maintenance Event 2008	South Yard	A steam condenser was designed and installed to reduce loading on the relief system during steam cleaning of the process equipment.  Use of a temporary condenser will be considered in future DHT turnaround events in order to minimize the amount of steam that flows to the relief header.

<i>Year Installed or Implemented</i>	<i>Flare System Affected</i>	<i>Equipment Item Added, Process Changed or Procedure Implemented</i>
December 2007, April 2008	Both	December 2007: A temporary back-up generator was installed. April 2008: A permanent back-up diesel generator has been added to the 5 H2S Emergency Scrubber C-840. The existing C-840 emergency scrubber prevents the burning of H2S in the flare by absorbing the H2S in an aqueous ammonia solution. A permanent back-up diesel generator was permitted, installed, and commissioned into service in 2008. This addition will not alter 5 H2S or C-840 operations. Instead, it will ensure continuous circulation of the scrubbing solution during an unexpected power outage and therefore maintain decreased H2S concentrations.
RLOP Area Turnaround 2009	North Yard	During the 2009 turnaround of the RLOP area, a cooldown process using recycle gas instead of NiCool to cool reactor vessels was tested. The goal of this cleanup technique was to reduce load on the FGR compressors.  This practice may be used during future turnarounds.
4CU Pitstop Maintenance 2009	South Yard	The 4CU Process Unit and several associated process plants in the Distillation and Reforming area will consider implementing the following practices to minimizing flaring during planned maintenance; de-pressure to relief at a slower rate per revised procedures and depressuring DHT to a downstream process unit to a lower pressure target before sending material to relief.  Operations implemented the identified flare minimization measures during a 2009 turnaround, and will consider implementing these practices in future turnarounds.
October 10, 2010	North Yard	Flare Minimization Planning for FCC Complex Turnaround. The FCC operating area is employing condensing systems to assist with flare minimization during its 2010 turnaround.
March 14, 2011	North Yard	Upgrade the North Yard FGR compressor's common electrical power supply system to separate feeders so that when one FGR compressor is shut down for maintenance, the other FGR compressor will be in service.
October 4, 2011	North Yard	Flare Minimization Planning for RLOP Complex Turnaround The RLOP operating area is employing condensing systems to assist with flare minimization during its 2011 turnaround.  A steam condenser was designed and installed to reduce loading on the relief system during steam cleaning of the process equipment.
October 6, 2011	South Yard	Flare Minimization Planning for D&R Complex Turnaround. The D&R ABU is employing condensing systems to assist with flare minimization during its 2011 turnaround.  A steam condenser was designed and installed to reduce loading on the relief system during steam cleaning of the process equipment.

## 4.0 Planned (Future) Reductions

Pursuant to the requirements of Regulation 12, Rule 12, Section 401.3, and 401.4.1 and 401.4.2 (feasible prevention measures) this section provides descriptions of any equipment, processes or procedures that the Richmond Refinery plans to install or implement to eliminate or reduce flaring.

Table 4-1 below summarizes planned improvements to effect further reductions in refinery flaring. The procedural changes described below require a year in order to optimize the improvements, update tools and communicate and train employees. The planned dates shown are driven by equipment installation and procedural changes that take advantage of the equipment.

Causal analyses of flaring events identified actions to maintain plant reliability that would reduce the likelihood of incidents which could cause potential flaring. These actions included the inspection and repair of equipment components that were either implemented as part of normal operations, or were scheduled for the next plant turnaround as described in Section 5.1.6 and Figure 5-1. Other actions are included in Table 4-1 below.

Table 4-1 includes measures considered to reduce flaring from planned major maintenance activities. There were no measures identified that were considered and rejected. Table 4-1 also includes measures considered to reduce flaring that may occur because of issues of flare gas quality and quantity. Measures that were considered but rejected are described in sections 5.2.4 and 5.2.5, including Table 5-3, under options considered for additional flare gas recovery, treatment, or use.

There were no other improvements considered that were not either included in Sections 5.2.4 and 5.2.5, or included in Table 4-1.

**Table 4-1 Planned Improvements to Reduce Flaring**

<i>Planned Date of Installation/ Implementation</i>	<i>Equipment Item to be Added, Process to be Changed or Procedure to be Implemented</i>	<i>Flare System Affected</i>	<i>Notes</i>
September 2012 – March 2013	K-1060 unloader valve replacements. K-1070 unloader valve replacements and frame replacement.	North Yard	Upgrade the North Yard FGR compressors with valve replacements and one structural frame replacement in order to improve the reliability.
October, 2012	Operation of the flares in a staged basis.	South Yard	The LSFO Flare (S-6010) and D&R Flare (S-6015) will operate on a staged basis. Under normal conditions, the D&R Flare will only operate once the LSFO Flare approaches its smokeless capacity. Flaring through the D&R Flare will therefore be minimized as specified in Condition No. 24921, Part 2. The LSFO Flare will remain the primary flare during any process unit startup or shutdown activities. When the LSFO Flare is out of

<i>Planned Date of Installation/ Implementation</i>	<i>Equipment Item to be Added, Process to be Changed or Procedure to be Implemented</i>	<i>Flare System Affected</i>	<i>Notes</i>
			service for maintenance, the D&R Flare will operate as the primary South Yard flare. When the D&R Flare serves as the only South Yard flare, the water seal level will remain set at a level higher than that of the LSFO Flare in order to further minimize flaring and maximize flare gas recovery and maintain safe operation.
To Be Determined (Note 2)	Install a new emergency caustic scrubber (C-2440).	North Yard	To prevent or minimize burning of H <sub>2</sub> S in the flare system, a new emergency caustic scrubber (C-2440) will be installed for removal of H <sub>2</sub> S from acid gases prior to routing to the relief system.
May 2007 – On Going	Source reduction		The source control program continues as an on-going function at the Refinery. In 2008, several source control actions were taken, including repairing V-910, V-920, and V-930 bypasses in the Hydrogen Manufacturing Plant and replacing two blowdown valves on V-2010 that are leaking by to relief.
January 2008 – On Going	Infra red (I.R.) camera has been used as a predictive maintenance tool.	Both	After a major overhaul, FGR compressors are inspected using the I.R. camera to evaluate compressor performance and to predict if maintenance is needed.
July 2007 – On Going	Site-wide flare minimization team	Both	A multidisciplinary team focused on flare minimization meets periodically to address the refinery's flare minimization issues. The team is made up of operations, planning, and environmental personnel. These meetings continue and action items are identified, considered, and implemented on an on-going basis throughout the year.

Note 2: The Richmond Refinery Energy and Hydrogen Renewal Project (Modernization Project) was postponed by legal action. In response to that action, the Environmental Impact Report (EIR) for the project was revised and re-approved by the City of Richmond. A timeline for re-starting project implementation is not known at this time.

## 5.0 Prevention Measures

### 5.1 Major Maintenance Activities

Pursuant to the requirements of Regulation 12, Rule 12, Section 401.4.1, this section discusses refinery maintenance and turnaround activities and outlines measures to minimize flaring during planned and unplanned maintenance activities. The section includes information on when flaring is likely to occur during maintenance activities, comments on the effects of recovered flare gas on downstream equipment, a review of flaring that has occurred during major maintenance activities in the past five years, and a description of measures that can be used to perform these activities with a minimum of flaring. For purposes of this section, planned maintenance is interpreted as scheduled process unit turnarounds as well as more near-term shutdowns planned within the refinery's maintenance planning process.

#### 5.1.1 When Flaring is Likely to Occur During Maintenance and Turnaround Activities

Maintenance activities may result in a higher than normal flow of material to the flare gas recovery system. In order to maintain process equipment, the first step is to clear the process equipment and associated piping of hydrocarbons, before the system is opened to the atmosphere, for both safety and environmental reasons, including compliance with BAAQMD Regulation 8 Rule 10, (Process Vessel Depressurization). For catalyst-containing vessels, hydrocarbon removal is also done to address solid waste disposal issues. How this is accomplished depends on the physical properties of the hydrocarbons to be removed (e.g., vapor pressure, viscosity, etc.) and on the process details of the equipment that is to be maintained.

Efforts are made to recover as much of the hydrocarbon as possible by transferring it for processing in another part of the refinery, i.e., one that is not undergoing maintenance. For example, liquid hydrocarbons can be pumped to tankage or another process unit; gases under pressure may be depressurized to another process unit. Heavy hydrocarbons that are viscous at ambient temperatures are often displaced from the equipment to be maintained using lighter hydrocarbons {e.g., light cycle oil (LCO)}. The LCO is then pumped from the equipment.

Although depressurization and pump-out can be used to remove the bulk of the hydrocarbon from the equipment, some residual material remains. Following pump-out or depressurization to other process equipment, the next step in preparing for maintenance typically requires a low-pressure location that has the ability to accept a wide range of hydrocarbon materials in order to avoid venting these materials to the atmosphere. The relief gas header is the only location within the refinery that meets these criteria. Equipment items containing materials that are gases at ambient temperatures and pressures are often vented to the flare gas recovery system so that the hydrocarbon can be recovered as fuel gas. To free equipment of hydrocarbons following depressurization, they can be purged using steam, an inert gas such as nitrogen, or recently certain recycle process gas streams have been used as a way of minimizing load on the relief system. The decision to use steam, nitrogen, or recycle gas depends on the nature of the material being purged; heavier hydrocarbon fractions are more effectively removed using the thermal properties of steam, while lighter fractions can be removed more effectively with nitrogen. The decision also depends on physical considerations such as avoiding causing corrosion by steam condensing or damaging catalysts. These assessments to determine the purge medium reduces flaring by ensuring that hydrocarbons are removed in the most effective manner, reducing the overall load burden on the FGR system.

For equipment containing liquids, steam or nitrogen are often used to "blow" the liquid to the relief gas header. The liquid hydrocarbon and condensed steam are separated from the vapor phase in knockout drums, and returned to the refinery's recovered oil or sour water systems.

Nitrogen with hydrocarbon vapor continues on to flare gas recovery. Once the bulk of the liquid hydrocarbon has been displaced, the flow of steam or nitrogen is continued to remove any residual hydrocarbon by vaporization. Steam can be more effective for heavier materials as it increases their volatility by increasing temperature.

Chemical cleaning by circulating solvents and proprietary aqueous solutions is used to de-oil or oxidize pyrophoric materials when present within equipment. These circulation operations are generally open to the relief system but do not have significant impacts on flare operations. Chemical cleaning can reduce the quantity of gas that needs to be flared (although the hydrocarbon-containing liquids must still be treated as an oily waste water). More often, chemicals are injected as part of the process of steaming-out equipment to the relief system. This facilitates the steam-out process and reduces the total time required for steaming-out equipment. The decision to use chemical cleaning is made as part of the IMPACT planning process. The chemical cleaning coordinator meets with each IMPACT team prior to the turnaround to develop this work scope.

Although these procedures eliminate hydrocarbon emissions related to equipment opening, they require a high volumetric, high velocity, steam or nitrogen flow rate in order to be effective. This high flow rate of inert gas can create several sets of circumstances where flare gas cannot be recovered due to the change in fuel gas composition (increased molecular weight or temperature) or to the increase in volumetric flow rate.

In addition to an increase in flare gas average molecular weight from a higher than normal nitrogen flow rate, there is also the potential for much lower than average molecular weight gas from increased flow of hydrogen. There are many process and reactor systems within a refinery that contain gases with high hydrogen content. When this equipment is depressurized to the relief gas header, there can be a sharp decrease in the flare gas average molecular weight. The effect of such changes in the quality of recovered relief gases can create situations where the FGR compressors cannot recover the gas without over-heating and possibly being damaged.

### 5.1.2 The Effect of Flare Gas on Downstream Equipment

Gas composition affects the equipment in the flare gas recovery system. Specifically:

- High nitrogen content can impact heaters, boilers and flare gas compressors.
- Hydrogen and other low molecular weight gases impact flare gas compressor performance.
- Steam impacts knock out drums and compressors, while increasing sour water production.

High flows of nitrogen from equipment purging lead to a much higher than normal inert content in the mixed flare gas and greatly reduce its fuel value (measured as Btu/SCF). When this low Btu flare gas is transferred to the fuel gas header, the lower fuel value can have the effect of reducing combustion efficiency, as the burners are designed to operate with fuels that have higher heat content per cubic foot. In extreme cases, the heating value of the gas can be reduced by dilution with nitrogen to the point of extinguishing the burner flame. This creates the potential for unburned fuel to accumulate in the heater or boiler, leading to a potential explosive risk when it is re-ignited. NFPA 85 – Boiler and Combustion Systems Hazards Code and NFPA 86 Standards for Ovens and Furnaces warn against this possibility.

The higher than normal nitrogen content of flare gas that can result from nitrogen purging has the effect of greatly increasing its molecular weight. Reciprocating compressors increase the pressure of a constant inlet volumetric flow rate of gas. For a given volume of gas, an increase in molecular weight creates an increase in its mass. This increases the work that the compressor has to do to compress the gas, overloading and potentially damaging the equipment.

For most flare gas systems that make use of reciprocating compressors, the compression ratio (outlet pressure/inlet pressure) is high enough that more than one stage of compression is needed. The temperature of the gas increases as it is compressed. The gas is cooled between stages in order to control the temperature increase. Operation of a reciprocating compressor with a feed stream that has a molecular weight outside of the range for which it was designed (e.g., high hydrogen content, etc.) can lead to a temperature increase exceeding the design limitations of the equipment. Continuing to operate at such temperatures can lead to serious damage and failure of the compressor.

A major advantage of using steam to clear hydrocarbons from equipment is its elevated temperature; however this can be a disadvantage with respect to flare gas recovery. When the distance the gas must travel to reach the flare gas compressor is large, (the relief header is long), the gas will cool, and much of the steam will condense and be removed as water at the knock-out drum. However, with a shorter flare line or a long-duration steam out event, the temperature of the flare gas at the flare gas compressor can be elevated significantly. If the temperature of the flare gas stream at the inlet to the flare gas compressor exceeds machine limits, the gas must be diverted away from the compressor inlet (i.e., to a flare) in order to avoid mechanical damage. Another disadvantage of the use of steam is that most of what is added as a vapor will condense in the relief gas headers and be removed via the water boot of a knock-out drum, either as the result of cooling as it flows through a long flare line or in a chiller/condenser included specifically for removal of water vapor from the flare gas. This creates a sour water stream requiring treatment.

Each of the situations described above potentially leads to the need to divert gas produced during refinery maintenance away from the flare gas compressor and to a flare. This is a necessary result of maintenance procedures which have been adopted to minimize the release of hydrocarbons to the atmosphere during equipment opening. The need to divert gas is driven by the quantity and composition of the gases produced during equipment shutdown and startup.

### **5.1.3 Past Flaring due to Major Maintenance Activities**

A review of maintenance-related flaring at the Richmond Refinery during the five years prior to the promulgation of Regulation 12, Rule 12 (on July 20, 2005 was completed and has been included in Table 5-1 of the original FMP. The implemented planned improvements to reduce flaring originally included the FMP's Table 4-1 have been updated and moved to Table 5-1 during the first FMP annual update.

The process used to develop information included in Table 5-1 was to review past flare plans for planned major maintenance work (prepared as part of the Richmond Refinery's existing shutdown planning process) as well as the available refinery annual release reporting summaries (containing actual flaring emissions calculated for major flaring events). These plans and reports were reviewed to identify dates, and to identify and understand general steps followed during shutdown and startup that might be expected to result in flaring. Lessons learned, resulting in the adoption of best practices and potential ideas for flaring reductions, were discussed with subject matter experts and are listed in the table for each general category of planned major maintenance work.

Based on the types of lessons learned from the 5-year review, the greatest potential for further cost-effective reductions in flaring is to update and improve existing operations and maintenance procedures. These flaring reduction measures satisfy safety and maintenance obligations, and also address the conditions (described in the preceding sections) that prevent recovery of relief gases. In practical terms this means taking a series of actions specific to the unit undergoing maintenance to limit the rate at which relief gases are generated and maintain gas temperature and composition within an acceptable range for handling by the flare gas



compressor and eventual use in a fuel gas system. Concepts for accomplishing this are discussed below in this section.

Per the IMPACT planning process for maintenance turnarounds a flare plan is prepared as part of the turnaround planning process. This plan identifies a schedule of discrete work steps such as pulling feed, shutting down, depressuring, and cleaning up units and equipment that could generate flare gas to relief. Consideration is given to whether relief gases can be recovered or routed to another location besides relief. The IMPACT process for planning major maintenance turnarounds includes a "lessons learned" session to incorporate learnings into the next subsequent turnaround. The Refinery has developed a process to formalize the "lessons learned" in order to capture and document learnings. Refer to the fuller description of the IMPACT planning process in Section 5.1.6 for how these activities and lessons learned would be applied to future turnarounds. Gases are routed to FGR compressors as long as the heat generated by compressing these gases does not exceed the discharge temperature of the compressor, which could damage it and, therefore, result in flaring due to the loss of FGR compressor operation. Section 5.2.4 addresses options for flare gas recovery, treatment and re-use.

**Table 5-1 Past Flaring During Major Maintenance Activities and Improvements Implemented**

<i>Date (s)</i>	<i>Description of Activity Resulting in Flaring</i>	<i>Lessons Learned from Past Actions</i>
January 2002 April 2002 September 2002 January 2003 March 2003 December 2003 January 2004 September 2004 November 2004 May 2005	4 & 5 Rheniformer regenerations	During the January 2003 regeneration, a test run was conducted. The Rheniformer's reactor section was depressured directly to the refinery's fuel gas system. Prior to this date, Rheniformer regenerations were conducted with the vent gases generated during the reactor depressuring step routed to the flare or FGR.
April 2002 February 2005	TKC plant shutdowns	TKC plant reactors were depressured (from 2600 to 275 psig) by routing gases to the #20 Plant (Hydrogen Recovery) rather than to the FGR system. Depressuring to hydrogen recovery or locations other than the relief system reduces the load on the FGR system, and reduces the likelihood of flaring. Evaluation of this is part of the IMPACT process. See Section 5.1.6 for the IMPACT process description.
November 2001 October 2003 January 2004 October 2004	TKC plant catalyst module change-outs	TKC plant catalyst modules (R-410/411 and R-420/421) were depressured (from 2600 to 275 psig) by routing gases to the #20 Plant (Hydrogen Recovery) instead of to the flare gas recovery system. Depressuring to hydrogen recovery or other locations besides the relief system reduces the load on the FGR system, and reduces the likelihood of flaring. Evaluation of this is part of the IMPACT process. See Section 5.1.6 for the IMPACT process description.

<i>Date (s)</i>	<i>Description of Activity Resulting in Flaring</i>	<i>Lessons Learned from Past Actions</i>
February 2001 January 2003	TKN-ISO plant shutdowns  (applies to module shutdowns as well)	TKN/Isomax plant reactor modules (R-610/620) were depressured from 1300 to 275 psig routing to #20 Plant (Hydrogen Recovery). TKN plant reactor (R-510) was also depressured to 20 Plant (H2 Recovery) instead of to the FGR system.
February 2001 January 2002 January 2003 January 2004 February 2005	H2 Manufacturing Trains	20 Plant/V-340 (natural gas) depressured to FGR (stay on FGR). 20 Plant is nominally part of the hydrogen train system- hydrogen trains themselves are not depressured to the flare when undergoing a turnaround. Depressuring 20 Plant to FGR is evaluated as part of the IMPACT process. See Section 5.1.6 for the IMPACT process description.
January 2002	RLOP complex: HNC/LNC/HNF/LNF	Depressure reactors to #20 plant (H2 Recovery) and then to FGR if possible. Depressuring to hydrogen recovery or other locations besides the relief system reduces the load on the FGR system, and reduces the likelihood of flaring. Evaluation of this is part of the IMPACT process. See Section 5.1.6 for the IMPACT process description.
January 2002	D&R complex: 4CU/4&5 Rhen/NHT/JHT/DHT/ Penhex Isom/Naphtha splitter/Reformate splitter	Route gases from rapid purge & depressurization with nitrogen ("pop and purge") to FGR instead of to flare as long as the heat that is generated by compressing the gases does not cause the operating temperature of the FGR system to activate the temperature alarm on the compressors.
November 2003	FCC / Alky planned	Route vent gas to FGR instead of to flare as long as the heat that is generated by compressing the gases does not cause the operating temperature of the FGR system to activate the temperature alarm on the compressors.
February 2005	SDA major shutdown	Route vent gas to FGR instead of to flare as long as the heat that is generated by compressing the gases does not cause the operating temperature of the FGR system to activate the temperature alarm on the compressors.
Multiple dates	FGR maintenance	Schedule necessary preventive maintenance on the FGR compressors at times when the demands on FGR system are low. Avoid scheduling maintenance during turnarounds as long as the key parameters monitored, including valve temperatures, oil temperatures, and stage pressures, indicate that the compressors can run reliably through the clean-up process. This reduces the likelihood that demands on the FGR

<i>Date (s)</i>	<i>Description of Activity Resulting in Flaring</i>	<i>Lessons Learned from Past Actions</i>
		system would exceed the capacity of the available FGR compressor, thus reducing the likelihood of flaring. Maintaining the FGR compressors prevents failures and keeps them operating. When the FGR compressors operate reliably, flare gases are recovered instead of flared.
October 2005	FCC major shutdown	Separated FCC and Alky flares after pulling feed from FCC unit in order to facilitate separate clean-ups of each unit. Specific improvement opportunities based on the FCC 2005 shutdown will be incorporated into the IMPACT planning process for future maintenance turnarounds when that turnaround scope is defined.
November 1, 2007	For each maintenance turnaround where nitrogen will be blown through vertical furnace tubes, an evaluation will be made by the IMPACT team on whether reducing the duration of purging or decreasing the nitrogen flow rate would still allow the tubes to be cleaned, which could reduce flaring where nitrogen cannot otherwise be recovered without exceeding the temperature limit of FGR compressors.	Incorporate for consideration as part of the updated flare planning procedure (see section 5.1.6). A checklist has been added to the flare planning procedure that requires an evaluation of the ability to reduce flaring by optimizing furnace tube blowing times when furnaces with vertical tubes are being cleared of hydrocarbon in this manner.
November 1, 2007	Reduce duration and/or decrease flow rate at which Nitrogen is used to purge plant equipment, as long as plant equipment can be cleaned-up for maintenance.	For each maintenance turnaround, an evaluation has been made by the IMPACT team on whether reducing the duration of purging or decreasing the nitrogen flow rate would still allow plant equipment to clean-up sufficiently for maintenance. This could reduce flaring where nitrogen cannot otherwise be recovered without exceeding the temperature limit of FGR compressors. See Section 5.1.6 for the IMPACT process. A checklist has been created and used to document the results of this evaluation.
November 1, 2007	#4 and #5 Rheniformers depressure directly to fuel gas system except if prevented by the piping configurations and/or	The catalytic reformers (#4 and #5 Rheniformers) have been directly depressured to the fuel gas system (rather than going through the relief gas header and flare gas recovery system) since 2003. A checklist has been

<i>Date (s)</i>	<i>Description of Activity Resulting in Flaring</i>	<i>Lessons Learned from Past Actions</i>
	manifolding of valves	added to the flare planning procedure that requires an evaluation of the ability to reduce flaring by continuing to depressor the catalytic reformers directly to fuel gas system.
Implemented Prior to August 1, 2006	<p>Update controls for RLOP plant's E-1900 to reduce risk of hydrate plugging problems.</p> <ul style="list-style-type: none"> <li>- low outlet temperature alarms on E1900 and E1901 heat exchangers,</li> <li>- valve position alarm on the temperature bypass valve at E1900,</li> <li>- reduce the set point for the low flow alarm on the 1<sup>st</sup> stage of K1900 compressor</li> <li>- valve position alarm on the pressure control valve to relief.</li> </ul>	<p>An extensive sampling effort was conducted to evaluate potential sources of chlorides into the relief system. It was determined that the source of chlorides into the relief system was caused by blowing down perchloroethylene lines to relief during steps in the catalyst regeneration process for the Rheniformers.</p> <p>Rheniformers upgrade lower octane feed to higher octane by passing a mixture of these hydrocarbons and hydrogen over a catalyst. The catalyst must be regenerated periodically. Perchloroethylene is used as a chloriding agent to rejuvenate the catalyst during the regeneration process. To reduce this source of chlorides, the 5 Rheniformer Regen Procedure was revised to lessen the amount of perchloroethylene that is purged to relief during the regeneration process. The main intent of these changes is to maintain lower levels of perchloroethylene in the perchloroethylene</p>
Study Concluded prior to August 1, 2006-and actions taken in August 2007	<p>Study and evaluate solutions to address South Yard Relief System's Ammonium Chloride issues (Abrasive ammonium chloride salts had built up in the K-3950 compressors, causing it to shutdown.). Issues resolved in August 2007.</p>	<p>An extensive sampling effort was conducted to evaluate potential sources of chlorides into the relief system. It was determined that the source of chlorides into the relief system was caused by blowing down perchloroethylene lines to relief during steps in the catalyst regeneration process for the Rheniformers.</p> <p>Rheniformers upgrade lower octane feed to higher octane by passing a mixture of these hydrocarbons and hydrogen over a catalyst. The catalyst must be regenerated periodically. Perchloroethylene is used as a chloriding agent to rejuvenate the catalyst during the regeneration process. To reduce this source of chlorides, the 5 Rheniformer Regen Procedure was revised to lessen the amount of perchloroethylene that is purged to relief during the regeneration process. The main intent of these changes is to maintain lower levels of perchloroethylene in the perchloroethylene injection pot, prior to moving to a step that requires the injection system to be purged. In addition, during certain steps the perchloroethylene will be emptied into the reactors to avoid purging it to the relief system. Two Carbon drums in series have been installed</p>

<i>Date (s)</i>	<i>Description of Activity Resulting in Flaring</i>	<i>Lessons Learned from Past Actions</i>
		on the bulk storage perchloroethylene drum (V-3592) off gas line to minimize formation of salts in the south yard relief system. Operating procedures have been revised and operator crews have been trained to follow these procedures.
November 1, 2007	Update of startup procedures to prevent equipment (such as plant recycle compressors) malfunction	An evaluation is made for each maintenance turnaround by the IMPACT team on whether clearing equipment of liquid by blowing nitrogen through it would be useful or required to prevent damage on start-up, and therefore reduce flaring by preventing unplanned malfunctions. A checklist has been created and used to document the results of this evaluation.
December 31, 2006 -complete	Upgrade relief line flow meters in the North Yard, and install additional new relief line flow meters in the South Yard.	Flow meters on the North Yard and South Yard relief system branch lines were upgraded to GE Sensing Model Number 868 meters. A total of 42 meters were installed, 17 in the South Yard and 25 in the North Yard. These meters are more accurate than the meters which were previously installed, making it easier to determine where sources are flowing into the relief system. Locating these sources enabled them to be controlled, thus reducing the load on the NY and SY FGR systems and therefore reducing the likelihood of flaring.
Implemented Prior to August 1, 2006 - complete	Upgrade and configure the RLOP Plant's K-1960 compressor to provide additional (spare) flare gas recovery capacity	K-1960 draws on and compresses vented vapors from many RLOP plants as well as relief gas from the North Yard flare system. K-1960 can be loaded and unloaded either automatically or manually on a local panel. K-1960 has a maximum capacity of 1.29 MM SCFD and normally runs at 100% of load (unless starting or shutting down unit). Commissioning K-1960 effectively reduced the load on the North Yard FGR system by 1.29 MMSCFD, thus reducing the likelihood of flaring occurring. Overall loading on the North Yard FGR system in SCFD can be monitored from desktop interfaces and compared to their combined capacity of 7.92 MMSCFD. K-1960 is a Cooper Energy Services two-stage reciprocating compressor.
Study Concluded prior to August 1, 2006	Study potential K-3950 Flare Gas Recovery compressor upgrades to handle gases with higher heat of compression	K-3950 is a Cooper Energy Services two-stage reciprocating compressor. A study concluded in June 2006 identified upgrades to enable K-3950 to handle gases with higher heats of compression, increasing the proportion of nitrogen that can be recovered. These included

<i>Date (s)</i>	<i>Description of Activity Resulting in Flaring</i>	<i>Lessons Learned from Past Actions</i>
		<p>valves with a wider port and larger valve area, and upgrading the sealing plates from steel to an engineered plastic. Upgraded suction valve actuators would eliminate the need for time-consuming adjustments every time they were removed. Completion of the internal modifications had been delayed because in order to manufacture the upgraded parts, several dimensions on each valve port had to be checked with K-3950 down and the valves removed. Completed in January 2007, these upgrades enable K-3950 to stay on-line longer during the shutdown clean-up process without damaging the machine, thereby reducing flaring</p>
<p>December 31, 2006</p>	<p>All refinery flares to be compliant with the requirements of federal New Source Performance Standards (NSPS), Subpart J</p>	<p>Six Refinery flares have been certified to be used only for start-up, shutdown or malfunction (SSM), and therefore would not be used for routine flaring. In order to meet this SSM requirement, source control efforts were implemented including monitoring of spare flare gas recovery capacity, identifying sources of increased flows to the flare gas recovery system, and actively pursuing elimination of increased flows. The seventh refinery flare was certified in October 2007 as complying with NSPS subpart J, and therefore only used for SSM.</p>
<p>November 1, 2007</p>	<p>Improvements on procedure for shutdown planning (and planned maintenance flare planning)</p>	<p>A maintenance work planning and scheduling procedure has been developed for evaluating the impact of flaring from planned maintenance work outside of plant shutdowns. The procedure incorporates a review for the impact on the relief/flare gas recovery system from performing planned maintenance work and the potential to minimize the flaring. In addition, for shutdown flare planning, a step has been added to the procedure to evaluate the flare plan for minimization opportunities including evaluation of items in the checklist referenced in other rows of this table. Lessons learned have been incorporated in the flare planning procedure.</p>
<p>Implemented Prior to August 1, 2006</p>	<p>Increase temperature alarm set points and procedures to take advantage of K-1060 and K-1070 Flare Gas Recovery compressor material upgrades.</p>	<p>K-1060 and K-1070 North Yard flare gas recovery compressors (Worthington, two stage, three cylinder, reciprocating) had modifications to internal parts and auxiliary systems to increase reliability and potential ability to handle gases with higher heats of compression (e.g., Nitrogen, Hydrogen). Internal modifications included material upgrades to piston parts. The internal modifications were completed in several stages, incorporating lessons learned to allow</p>

<i>Date (s)</i>	<i>Description of Activity Resulting in Flaring</i>	<i>Lessons Learned from Past Actions</i>
		for a slight increase in operating temperature, which would enable plants to stay on FGR for a longer period of time during some clean-up operations. Modifications to auxiliary systems including adding a spare pump to the FGR compressor knockout drum to reduce the chance of the system shutdown, and adding supplemental cooling to a relief drum to enhance gas recovery. The higher discharge temperature for K-1060 and K-1070 and measures to increase reliability will directionally allow plants to remain on FGR for longer periods during shutdown purge and cleanup operations, and start-up activities.
November 1, 2007	Initial reactor depressure from high to low pressures (275 psig) are routed to the Hydrogen Recovery Plant 20, or other suitable process location. The secondary depressure vent gas is sent to the flare or flare gas recovery dependant on if compressor capacity is available.	For each maintenance turnaround an evaluation has been made by the IMPACT team on whether North Yard reactors can be depressured to Hydrogen Recovery Plant 20, or other plants, instead of to relief, and therefore reduce the quantities of gas that must be flared. Depressuring the hydrogen to other process locations reduces flaring by allowing the hydrogen to be consumed within the process system, and by routing it to a process system rather than sending it to flare gas recovery, it frees up capacity on the FGR compressor to manage the overall flare load more effectively. See Section 5.1.6 for the IMPACT process. A checklist has been created and used to document the results of this evaluation.
November 1, 2007	Route purge gases from DHT, JHT, and NHT plant shutdowns to #5H2S plant or alternate process locations, except if #5H2S is down, or gases contain too much nitrogen or steam to introduce to the fuel gas system.	For each maintenance turnaround an evaluation will be made by the IMPACT team on whether DHT, JHT and NHT plant turnarounds can be purged to #5H2S or other process locations, instead of to relief, and therefore reduce the quantities of gas that must be flared. See Section 5.1.6 for the IMPACT process. A checklist has been created and used to document the results of this evaluation.
December 31, 2007	Conversion of K-242-and K-252	K-242 and K-252 compressors have been converted to provide additional flare gas recovery capacity in the South Yard. These conversions provide additional, dedicated flare gas recovery compressor capacity and reduce the dependency on the dual role K-1171 and K-1171A compressors. K-242 and K-252 compressors are Worthington two-stage, reciprocating units with a capacity of between 1.9 and 2.3 MMSCFD per compressor,

<i>Date (s)</i>	<i>Description of Activity Resulting in Flaring</i>	<i>Lessons Learned from Past Actions</i>
		<p>depending on the molecular weight of the gas. Either K-242 or K-252 compressor is available for back-up FGR service (with the other compressor in dual process/FGR service).</p> <p>K-242/K-252 provide approximately 2 MMSCFD dedicated back-up capacity to the existing flare gas recovery capacity of 2.35 MMSCFD provided by K-3950. With an additional 1.7 MMSCFD available from the dual service K-1171 and K-1171A, a total of 6.1 MMSCFD flare gas recovery capacity is provided against the current base load of 0.8 MMSCFD.</p> <p>The conversion of K-242 and K-252 was completed in December 2007.</p>
June 2011	North Yard FGR compressor electrical power upgrade	Upgrade the North Yard FGR compressor's common electrical power supply system to separate feeders so that when one FGR compressor is shut down for maintenance, the other FGR compressor will be in service.
October 4 – 11, 2011	RLOP complex: HNC/LNC/HNF/LNF	A steam condenser was designed and installed to reduce loading on the relief system during steam cleaning of the process equipment. Evaluation of this is part of the IMPACT process. See Section 5.1.6 for the IMPACT process description.
October 8 – 12, 2011	D&R complex: 4CU/4&5 Rhen/NHT/JHT/5H2S/ Penhex Isom	A steam condenser was designed and installed to reduce loading on the relief system during steam cleaning of the process equipment. Evaluation of this is part of the IMPACT process. See Section 5.1.6 for the IMPACT process description.

#### 5.1.4 Past Flaring Activities Requiring Causal Analyses

A list of flaring activities that required causal analyses at the Richmond Refinery beginning on June 1, 2006 to present is compiled and has been included in Table 5-1a of the FMP annual updates. The description of the cause (or causes) and any contributing factors resulting in these flaring activities are included in this FMP annual update.

Lessons learned, resulting in the adoption of best practices and potential ideas for flaring reductions, were discussed with subject matter experts and are listed in the table for each flaring activity that resulted in causal analyses to be conducted.



Table 5-1a Flaring Activities Requiring Causal Analyses (June 1, 2006 – June 30, 2013)

<i>Date</i>	<i>Description of Activity Resulting in Flaring that Required Causal Analyses</i>	<i>Lessons Learned</i>	<i>Flaring Activity caused by an Emergency or Other Cause</i>
June 25, 2006	TKC reactor module shutdown for periodic maintenance and catalyst replacement.	The shutdown was conducted in a planned and controlled manner and efforts were made to minimize flaring duration and the quantity of emissions. The IMPACT team has been continuously improving TKC module shutdown procedures and flaring due to catalyst replacement has been significantly decreased.	Shutdown – Not Emergency
July 11, 2006	Flaring was primarily caused by the shutdown of the instrument air compressor K-2600 due to a failed main electrical contact. A check valve in a 6" line in K-2600 air system piping prevented other instrument air compressors in the refinery-wide system from providing enough back-up instrument air to maintain pressure within normal operating range.	The failed electrical contact was replaced with a new in-kind contact. The check valve from the 6" line was removed to allow other instrument air compressors in the refinery-wide system to provide enough back-up air when K-2600 is shutdown. K-400 actuator instrument air supply lines were repaired.	Malfunction – Not Emergency
July 21, 2006	Flaring occurred during conditions of high ambient temperatures when FGR capacity was exceeded at the D&R ABU due to extra volume of relief gases from a reflux drum in the #4 Crude Unit.	Additional guidance was issued for Naphtha Stabilizer Column C-1190 off gas reduction during high ambient temperature periods. Operations reviewed the unit source control checklist to include all sources and conducted field audits to identify and fix any leaks.	Not Emergency
August 9, 2006	Flaring occurred during conditions of high ambient temperatures when FGR capacity was exceeded at the D&R ABU. A leaking PSV had also contributed to this flaring event. Replacing this PSV required a plant shutdown.	In addition to the activities taken following the July 21, 2006 flaring event, operations shutdown the 5 NHT Plant and replaced the leaking PSV. Since this date, no high ambient temperature related flaring has occurred.	Not Emergency
August 31, 2006	Flaring occurred due to an unplanned shutdown of FGR compressors K-1171 and K-1171A, associated with a N <sub>2</sub> purge line, which was inadvertently left open.	Operations blinded the nitrogen purge line to the #4 Crude Unit. The nitrogen purge lines are added to the source control checklist.	Not Emergency
November 10, 2006	A faulty sequencing valve in the hydrogen recovery unit allowed hydrogen to over pressure the knock out vessel for feed gas compressor K-1900 and relief gases exceeded the FGR capacity.	The valve was replaced. A corrective action was developed to assist operators in the monitoring of valve performance and more effectively preventing and diagnosing valve failure.	Malfunction – Not Emergency

<i>Date</i>	<i>Description of Activity Resulting in Flaring that Required Causal Analyses</i>	<i>Lessons Learned</i>	<i>Flaring Activity caused by an Emergency or Other Cause</i>
December 29 and December 30, 2006	The unexpected failure of power transformer TX-408 at RLOP caused the loss of power transformer TX-404 and the shutdown of the recycle gas compressor K-1600 and the vent gas compressor K-1960. The 2-554 breaker panel door vibrated upon closing, tripping an electrical breaker and resulting in a power failure to the lube oil pump P-1902. The consequent loss of lube oil pressure resulted in the shutdown of K-1900. The automatic pump start (APS) on P-1902A, the spare of P-1902, did not start up P-1902A fast enough to prevent a pressure drop in the K-1900 lube oil system to prevent K-1900 from shutdown.	Lube oils pump integrity was enhanced by upgrading electrical and instrument systems. The failed sudden-pressure switch in the transformer was replaced. A task was added into the preventive maintenance program so that the transformer is tested every three to five years as recommended by the manufacturer. Aligned all doors on breaker panel for the RLOP power center and added door alignment check to routine electrical preventive maintenance program. Installed vent lines at the top of both P1902 and P1902A to remove the air-pocket when a pump is stand-by so that during an emergency situation the pump will have sufficient pressure to start quickly therefore avoiding a K-1900 shutdown.	Malfunction – Not Emergency
January and February, 2007	During a planned plant maintenance turnaround at the D&R ABU, an incident occurred that necessitated the shutdown of FGR compressors that compounded the flaring quantity and duration.	Flaring was caused by the need to perform planned maintenance in the D&R ABU. A flare plan was prepared as part of the maintenance turnaround planning process. An incident occurred that made the FGR compressors unavailable, compounding the quantity and duration of flaring.	Shutdown – Emergency
January 17 – 25, 2007	Flaring occurred during a planned major turnaround for maintenance work at the RLOP process unit.	Flaring was caused by the need to perform planned maintenance in the RLOP process unit.  High levels of non-hydrocarbons in the relief gases required isolation of the RLOP process unit from the North Yard Flare Gas Recovery System.	Shutdown – Not Emergency
March – April 2007	Flaring occurred during the D&R startup following the planned maintenance turnaround: March 29, 2007 Isolation of a piping system for a drain valve replacement required product splitter C-240 overhead gases to be routed to the relief header and resulted in flaring.	The drain valve was replaced.	Startup – Not Emergency

<i>Date</i>	<i>Description of Activity Resulting in Flaring that Required Causal Analyses</i>	<i>Lessons Learned</i>	<i>Flaring Activity caused by an Emergency or Other Cause</i>
	<p>March 31, 2007 Blocking-in a valve at K-940 suction manifold caused hydrogen product from #4 Rheniformer to be routed to the D&amp;R relief system and the relief gases exceeded the FGR capacity.</p> <p>March 31, 2007 Routing hydrogen from #5 Rheniformer during its start-up to the D&amp;R relief system caused flaring.</p> <p>April 1, 2007 A high liquid level in the knock-out drum of FGR compressors K-1171 and K-1171A caused the compressors to trip.</p>	<p>Unblocked K-940 suction and corrected the suction manifold. Retrained operators on proper procedures when blocking the K-940 suction.</p> <p>Operation procedures were updated to avoid sending hydrogen from #5 Rheniformer during its start-up to relief system.</p> <p>A closed valve at the bottom of C-1180 was identified and opened.</p>	
April 23, 2007	Flaring occurred due to unplanned shutdown of feed gas compressor K-1900 during the HNC plant startup.	Operations updated start-up procedures and conducted operator crew discussion on actions taken in response to high priority alarms. A total column level alarm was added on all HNC distillation sections.	Startup – Not Emergency
May 10, 2007	TKC reactor module shutdown for periodic maintenance and catalyst replacement.	The shutdown was conducted in a planned and controlled manner and efforts were made to minimize flaring duration and the quantity of emissions. The IMPACT team has been continuously improving TKC module shutdown procedures and flaring due to catalyst replacement has been significantly decreased.	Shutdown – Not Emergency
April 29, 2008	Flaring occurred due to K-1900 surging during the HNC plant start-up and overloaded the FGR compressor capacity.	Operating procedures and engineer guidance were updated to minimize bleeding hydrogen and impurities from V-1410 to the PSA plant. An alarm at the distributed control system (DCS) to indicate E-1900 pressure drop was added to help operators identify if E-1900 is plugging. Feed gas density analyzer for K-1900 will be replaced by April 30, 2009.	Startup – Not Emergency
April 29, 2008	Flaring occurred due to a pump failure because of a faulty relay at the GRU unit in North Isomax.	The faulty electrical relay was identified and replaced.	Malfunction – Not Emergency
September 1, 2008	Flaring occurred due to liquid building up in V-1900, the suction	The following corrective actions were taken: (1) A parallel steam trap was installed; (2) the check	Malfunction – Not Emergency

<i>Date</i>	<i>Description of Activity Resulting in Flaring that Required Causal Analyses</i>	<i>Lessons Learned</i>	<i>Flaring Activity caused by an Emergency or Other Cause</i>
	knock out drum of K-1900, which caused the K-1900 compressor to shutdown. The cause was identified to be failure of the steam trap at the automatic eductor. The check valve did not hold to prevent condensate backflow.	valve was inspected and confirmed to be working properly; (3) a skin temperature indicator (TI) with alarm was installed to help identify condensate backflow; (4) an operator routine duty was added to periodically run the manual eductor; and (5) a guide was developed for troubleshooting the automatic eductor.	
August 21, 2009	On August 21, 2009, a malfunctioning valve positioner caused the shutdown of TKN hydrogen recycle gas compressor K-500. The shutdown of K-500 required an emergency shutdown of a portion of the TKN Unit in the North Isomax (NISO) business area. Flaring occurred at the NISO Flare when TKN reactors were depressured in order to maintain a safe operating posture of the unit.	The following corrective actions were taken: (1) Disassembled and inspected instrument air lines to the valve positioner; (2) Evaluated effectiveness of the coalescing filter and replace with a new device, if appropriate.	Malfunction – Not Emergency
November 19, 2009	On November 18, 2009, the feed gas compressor (K-1900) to the Richmond Lube Oil Plant (RLOP) operating area shut down and caused flaring at the RLOP, Fluid Catalytic Cracking (FCC), and South Isomax (SISO) flares. The compressor shutdown occurred when an operator inadvertently flipped the emergency shutdown switch for K-1900 on the manual control board when he intended to hit an adjacent switch.	The following corrective action was taken: Removed V-1900 eductor switch from emergency control panel.	Not Emergency
January 12, 2010	A block valve downstream of pressure control valve PC-4000 in the TKC Unit developed a leak to atmosphere and resulted in the unplanned shutdown of the TKC Unit.  The leak occurred due to failure of internal valve packing material, which allowed a leak to develop within the valve internals.	The following corrective actions were taken: (1) Replaced failed PC-4000 2nd downstream block valve; (2) Developed a list of Orbit valves in service in the TKC Unit, and created a standing Preventive Maintenance (PM) action in the maintenance tracking system for those valves.	Malfunction – Not Emergency
May 30, 2010	The Fluid Catalytic Cracking (FCC) Unit experienced an emergency shutdown due to a trip of the Main	The following corrective action was taken: Evaluated continuous use of disk cooling steam will prevent	Malfunction – Not Emergency

<i>Date</i>	<i>Description of Activity Resulting in Flaring that Required Causal Analyses</i>	<i>Lessons Learned</i>	<i>Flaring Activity caused by an Emergency or Other Cause</i>
	Air Blower Train (MABT) caused by high vibrations in the expander section of the MABT. The MABT provides compressed air to the reactor/regeneration portion of the FCC and is made up of rotating equipment, which operate within vibration limitations. The expander section experienced high vibrations associated with catalyst spalling off the expander blades leading to uneven weight distribution on the rotating equipment.	catalyst adherence to MABT expander disk.	
November 18, 2010	A cooling water pump (TP-460) for E-3580, cooler on the 4Rheniformer reactor effluent, shut down unexpectedly and led to liquid accumulation in V-912A, the knock out drum for K-900A compressor. K-900A shut off as a result of high liquid level in V-912A causing process gases to flow to the relief system.	The following corrective actions were taken: (1) Inspect and conduct necessary maintenance on over speed trip (OST) valve in steam system and the turbine pump (TP-460); (2) Inspect the governor that regulates speed of the turbine and repair or replace if needed; (3) Designs engineering to evaluate pump and compressor system design; (4) Verify correct operation of level controller on V-912A; and (5) Create a procedure/job aid to prepare cooling water pump for operation that explains the steps of bleeding air out of the case.	Malfunction – Not Emergency
June 21, 2011	A depressurization valve, 502B, on adsorption bed V-2072 of the Pressure Swing Adsorption (PSA) Unit in the Hydrogen Recovery Plant of the South Isomax area malfunctioned. The valve malfunction resulted in PSA Unit feed gas (sweet, hydrogen rich process gas) and product gas (99.9% pure hydrogen) entering the off gas line. The flow of gas caused the pressure controller on the suction side of the feed gas compressor, K-1900, in the Richmond Lube Oil Plant (RLOP) Gas Recovery Unit to open and subsequently, process gases were sent to relief.	The following corrective action was taken: Maintenance was performed on the PSA depressurization valve on adsorption bed V-2072. The valve positioner for this depressurization valve was replaced.  Preventative Maintenance program was designed and is currently implemented.	Malfunction – Not Emergency
October 4 –	Flaring occurred during a planned major turnaround for maintenance	Flaring was caused by the need to perform planned maintenance	Shutdown – Not Emergency

<i>Date</i>	<i>Description of Activity Resulting in Flaring that Required Causal Analyses</i>	<i>Lessons Learned</i>	<i>Flaring Activity caused by an Emergency or Other Cause</i>
11, 2011	work at the RLOP process unit.	in the RLOP process unit. High levels of non-hydrocarbons in the relief gases required isolation of the RLOP process unit from the North Yard Flare Gas Recovery System. A steam condenser was designed and installed to reduce loading on the relief system during steam cleaning of the process equipment.	
October 8 – 12, 2011	Flaring occurred during a planned major turnaround for maintenance work at the D&R ABU.	Flaring was caused by the need to perform planned maintenance in the D&R ABU. A flare plan was prepared as part of the maintenance turnaround planning process. A steam condenser was designed and installed to reduce loading on the relief system during steam cleaning of the process equipment.	Shutdown – Not Emergency
December 20, 2011	<p>A steam driven reboiler circulation pump (P-447A) at the No. 5 Naphtha Hydrotreater (5 NHT) of the Distillation and Reforming (D&amp;R) Unit unexpectedly shut down and caused the safety shutdown system of fuel gas to the 5 NHT furnace, F-447 (S-4062), to initiate, as designed. There is a fuel gas regulator valve on the F-447 safety shutdown system; however, the regulator valve malfunctioned. The combination of the loss of the reboiler circulation pumps with the malfunction of the regulator valve resulted in an unexpected shutdown of both 5 NHT furnaces F-410 (S-4061) and F-447 (S-4062) and subsequent shutdown of the 5 NHT plant.</p> <p>In normal operation, the naphtha from the Jet Hydrotreater (JHT) at the D&amp;R Unit is routed to 5 NHT. During the upset, operations was unable to reroute the naphtha away from 5 NHT, which resulted in process gases being routed to the FGR system, as designed.</p>	The following corrective actions were taken: (1) Maintenance will be performed on the reboiler circulation pump P-447A; (2) Check the configuration of the F-447 safety shutdown system for the fuel gas trip points for minimum fire trip and the full furnace trip settings; (3) Inspection will be performed on F-447 fuel gas regulator valve; and (4) Update the procedure for routing naphtha to alternate destinations for situations where the primary destination, 5 NHT, is not available.	Malfunction – Not Emergency

<i>Date</i>	<i>Description of Activity Resulting in Flaring that Required Causal Analyses</i>	<i>Lessons Learned</i>	<i>Flaring Activity caused by an Emergency or Other Cause</i>
February 27, 2012	<p>An operator was conducting a pressure survey of Hydrogen Plant A-Train (H2A) furnace F-305 feed gas orifice plate for compliance with Greenhouse Gas Regulations. In order to conduct the test, the Control Board Operator put the feed and steam control valves in manual operation after viewing the controls logic screen. The control logics screen did not identify the presence of a feed forward control system for the fuel gas and was not put in manual. Upon conducting the pressure survey, the feed-forward control for F-305 caused the fuel gas control valve to close on Cell B. The regulator valve for the fuel gas feed to F-305 malfunctioned causing a full shut down of the furnace and the H2A train.</p> <p>Hydrogen Plant B-Train (H2B) furnace (F-355A) developed a fuel gas leak, requiring that the F-355A-cell of H2B to be taken offline. This caused an additional loss of H2 delivery to H2-consuming plants, causing a loss of pressure. The resulting loss of pressure to the feed compressor (K-1900) for the Gas Recovery Unit (Plant 19) caused K-1900 suction pressure to fluctuate, resulting in a large amount of gas entering the flare gas recovery system.</p>	<p>The following corrective actions were taken: (1) Updated controls logic screen to include the feed forward control system for the fuel gas feed to F-305 of H2A; (2) Investigated design and control system for the minimum flow trip on the fuel gas regulator safety shutdown system and identify any potential improvements; and (3) Follow inspections recommendations for pig tail maintenance/replacement during next planned shutdown of both Hydrogen plants (H2A and H2B).</p>	Not Emergency
April 26, 2012	<p>Beginning in February 2012, the vibration alert levels began increasing from the thrust probes on TK-1400 (the steam turbine for the recycle compressor, K-1400) in the Heavy Neutral Hydrocracker (HNC) plant. Suspecting that the thrust probes readings were false, maintenance personnel shut down K-1400 and cleaned the connections on April 24, 2012 and then returned K-1400 back into service.</p> <p>Around April 25, 2012, the TK-1400 thrust probes once again detected an increase in vibration and</p>	<p>The following corrective actions were taken: (1) Modify the TK-1400 thrust probe cable conduit between turbine and driver enclosure so as to allow cable installation without damage to cables; (2) Develop/implement a thrust probe conduit inspection checklist to be used for all future thrust probe cable installations; and (3) Issue a bulletin communicating the lessons learned from this incident to reinforce the correct responses based on the available data to Operations and Reliability</p>	Malfunction – Not Emergency

<i>Date</i>	<i>Description of Activity Resulting in Flaring that Required Causal Analyses</i>	<i>Lessons Learned</i>	<i>Flaring Activity caused by an Emergency or Other Cause</i>
	<p>operators reduced the machinery speed to minimize vibration. On April 26, 2012 the TK-1400 thrust probes completely failed and consequently triggered the compressor's electronic over-speed shutdown system, as designed.</p>	<p>personnel.</p>	
<p>August 6, 2012</p>	<p>On August 6, 2012, a piping failure occurred in the #4 Crude Unit. The failure involved an 8" carbon-steel atmospheric gas-oil pipeline from the atmospheric distillation tower causing a fire and subsequent flaring.</p>	<p>The following Corrective Actions were taken: (1) Informed Chevron, all other Bay Area refineries and American Petroleum Institute (API) of sulfidation corrosion of low-silicon carbon steel and the process safety risks involved; (2) Revised policies and checklists to ensure appropriate information is considered when evaluating leaks and addressing the issue of whether to shut down or continue operation of equipment; (3) Conducted a 100% component inspection of carbon steel piping circuits exposed to high temperature (500°F and above) sulfidation corrosion to ensure sufficient wall thickness; (4) Implemented a process that provides additional oversight of mechanical integrity-related inspection recommendations; and (5) Improved the reliability program for piping and equipment to ensure it covers potential damage mechanisms applicable to those systems.                      Remaining Corrective Actions: (6) Implementing an enhanced process to better review, prioritize, and track to completion mechanical integrity-related recommendations from internal and external technical experts, including industry standards and alerts; and (7) A pilot was conducted with external technical expert to determine how to best enhance the existing work process to develop piping asset</p>	<p>Not Emergency</p>



<i>Date</i>	<i>Description of Activity Resulting in Flaring that Required Causal Analyses</i>	<i>Lessons Learned</i>	<i>Flaring Activity caused by an Emergency or Other Cause</i>
		strategy plans. The work process will be in place with a schedule for complying for all piping circuit asset strategy plans.	
February 8, 2014	An Area Operator (AO) was performing a scheduled alarm test on the 5 Rheniformer (5 CAT) hydrogen (H2) recycle compressor (K-550) lube oil system in the D&R Unit. The AO incorrectly activated the compressor emergency block valve (EBV) bypass instead of the compressor shutdown bypass, as specified in the alarm test method, which resulted in the compressor shutting down. Subsequently, the 5CAT Plant furnaces were shut down on loss of recycle hydrogen when K-550 was shut down. The shutdown of 5CAT Plant resulted in loss of H2 to the H2-consuming plants in the D&R Unit and required those plants to be shut down. During Operations' efforts to restart the plants in the D&R Unit, H2 was imported from the hydrogen export line through hydrogen booster compressor, K-900A, to the H2-consuming plants. K-900A was shut down at 13:11 due to concern of an increase in valve temperature.	The following Corrective Actions were taken: (1) Reviewed the Criticality Index for testing K-550 low lube oil pressure shutdown switches for the Rheniformer plants and determined that the existing test method was inadequate. A procedure checklist was then developed; and (2) Reviewed and approved the 5 CAT Plant emergency procedure to state immediately pull feed upon loss of hydrogen compressor. Remaining Corrective Action: (3) Develop an emergency procedure for situations when HEL hydrogen is needed and when K-900A and both 4 CAT and 5 CAT plants are shut down.	Not Emergency
April 16, 2014	At approximately 11:22 AM on April 16, 2014, Chevron Control Systems personnel turned over controls to the Honeywell Inc. Programming Specialist for the download and activation of a new control system software. Upon activation of the new control system software and deactivation of the previously used control system software, an unidentified flaw in the logic de-energized the control valve solenoids (FV304, FV308, FV311) for the natural gas feed to the SRU #3 furnaces (F-2301, F-2302 and F-2303), which resulted in the shutdown of the	The following Corrective Action was taken: Modified control systems procedure to include cautionary language around possible consequences before proceeding during online changes process review. The caution is meant to identify hazards surrounding use of critical control system upgrades or changes that can result in a plant shutdown.	Not Emergency

<i>Date</i>	<i>Description of Activity Resulting in Flaring that Required Causal Analyses</i>	<i>Lessons Learned</i>	<i>Flaring Activity caused by an Emergency or Other Cause</i>
	SRU #3 Plant. The shutdown of SRU #3 Plant, which normally receives feed gas from the #4 Hydrogen Sulfide (#4 H <sub>2</sub> S) Plant, resulted in an increase in pressure at the SRU plant feed system and at the #4 H <sub>2</sub> S Plant. Operational moves were made to relieve the excess pressure by routing the H <sub>2</sub> S containing gas to H <sub>2</sub> S scrubbers C-890 in #8 Plant and then to the emergency scrubber, C-840 in #5 H <sub>2</sub> S Plant.		

**5.1.5 Measures to Minimize Flaring During Planned Maintenance**

The Richmond Refinery has identified practices to minimize future flaring during planned maintenance activities. Specific lessons learned from recent shutdowns are shown above, in Table 5-1. These and other possible measures are also described below in more detail.

These possible measures are applied in several different manners. Maintenance of pressure relief devices to API Standard 510 is performed on a continual basis according to a set interval for each device. Flare gas recovery compressors are maintained according to weekly and/or continuous monitoring. (See also Section 2.1.) The applicability of each of the other possible measures highlighted below would be evaluated as part of the IMPACT planning process to minimize or eliminate flaring on a case-by-case basis. (See Section 5.1.6 for the IMPACT process.)

Lessons learned from the IMPACT process can include the considerations for recovery in Section 5.2.4. Gases are routed to FGR compressors as long as the heat generated by compressing these gases does not exceed the discharge temperature of the compressor, which could cause damage to the compressor and ultimately result in flaring due to the loss of FGR compressor operation. Additionally, the feasibility of providing additional compression, storage, and treatment options was looked into as a part of the assessment of measures to prevent flaring. These options were determined to be infeasible based on costs. Section 5.2.4 addresses options for flare gas recovery, treatment and re-use. Chevron examined the feasibility of performing each of the major maintenance activities below without flaring. As a result of this examination, the following measures were determined:

**Hydroprocessing**

High pressure units are first depressurized to a suitable process location (such as the hydrogen recovery unit), or other lower pressure location, and only after this are they depressurized to the relief system, reducing the load on the flare gas recovery system.

Following the initial depressurization, the remaining hydrocarbon is removed by increasing the pressure in the equipment with nitrogen and then depressurizing it to the relief system multiple times. Performing the depressurization quickly helps with mixing, which improves the efficiency

of hydrocarbon removal from the vessel so that fewer overall cycles of purging and depressurization are needed.

In the most recent RLOP 2011 shutdown, a temporary steam condenser was used and the process gas flows to relief generated by the RLOP maintenance activity was isolated from FGR in order to allow the remaining NY plants to stay on FGR without overwhelming the systems and causing further flaring. Employing these techniques successfully decreased flaring during major maintenance activity and will be incorporated into IMPACT planning process for future maintenance turnarounds.

### **Cracking**

Specific improvement opportunities based on the FCC 2005 shutdown were incorporated into the most recent FCC 2010 shutdown, which successfully decreased flaring during major maintenance activity. The techniques used in the FCC 2010 shutdown will be incorporated into IMPACT planning process for future maintenance turnarounds.

Chevron will consider and implement feasible prevention measures, including extending purge sequences when consistent with safe and reliable operations, to reduce emissions and minimize impacts on the relief system by avoiding overloading of the available flare gas recovery system capacity.

### **Catalytic Reformer**

Prior to performing maintenance, low sulfur process gases are depressured directly to the refinery's fuel gas system rather than to the relief header and flare gas recovery system.

The timing of the (periodically conducted) regeneration cycles is controlled and the venting / depressuring rate is limited to be within the available capacity of the flare gas recovery system.

### **Furnaces Pass Tubing**

When vertical furnace pass tubes are to be cleared of hydrocarbon (which can accumulate at the low points of the tube bends) by blowing with nitrogen, the duration of nitrogen flows can be minimized by first inspecting each of the tube passes and making adjustments to the standard recommended nitrogen blowing times.

The duration of the nitrogen blowing can be minimized to be within the available capacity of the flare gas recovery system.

### **Depressurization**

Alternate "routes" for depressurization of equipment are used so that routing gas through the relief header and flare gas recovery system is not necessary if the gas is at pressures sufficient for direct routing to the treating plant, or, for gases not requiring sulfur removal, to another process unit or into the refinery's fuel gas system.

This would eliminate gases from impacting the flare gas recovery system generated by depressurization of certain plants within the Refinery.

### **Pressure Relief**

Maintenance, inspection and servicing of Pressure Relief Devices (PRDs) is carried out according to Refinery Instruction 609 (RI-609), which summarizes requirements in American Petroleum Institute (API) Standards 510 and 570, API Recommended Practices 520 and 576,

National Board Inspection Code (NBIC), and California Code of Regulations Title 8, Chapter 4, Subchapter 1, 2, and 15. This refinery instruction establishes policies for servicing, testing, and recordkeeping of PRDs that protect pressure vessels, piping, and other equipment. RI-609 ensures that proper service intervals for PRDs are established and followed, and that PRDs are properly serviced and tested. The use of RI-609 minimizes flaring by optimizing intervals for testing of PRDs and inspection, thus reducing impacts to the relief system. In addition, ensuring PRD reliability results in fewer malfunctions and therefore less likelihood for flaring.

### **Flare Gas Recovery Compressors**

The operating temperatures of the flare gas recovery compressors are monitored, so that relief gases may be diverted away from the flare gas compressor only when outside of the range that the compressors can safely handle.

Process unit compressors (e.g., K1960 in the North Yard, K-1171/K-1171A and K-242/252 in the South Yard) with spare capacity are configured for optional use in flare gas recovery service. The regular flare gas compressors are part of a utility system and need to be online except during maintenance or when not needed for capacity reasons.

Flare gas compressors are maintained during periods of minimum capacity needs and/or following planned process unit shutdowns in the areas they serve, so there are fewer issues during periods of normal operation. A planned shutdown provides an opportunity to do maintenance, since relief gas loads from the inoperative plant are not entering the system.

Regular preventative maintenance of flare gas compressors is used to improve their reliability.

### **Shutdown/Startup planning & Shutdown Procedures**

A shutdown flare plan is developed for each turnaround. The plan identifies possible sources of flaring and incorporates some choices of action for the turnaround that can minimize flaring. Each plan is unique to the planned activity for a particular turnaround. Specific actions planned for the turnaround depend on which parts of the unit are being brought down and which other units are also down at the same time.

Equipment is purged at a rate which will remove hydrocarbons to allow access for maintenance, and minimize impacts to the relief system by avoiding overloading of the available flare gas recovery system capacity. Following the initial depressurization, the remaining hydrocarbon is removed by increasing the pressure in the equipment with nitrogen and then depressurizing it to the relief system multiple times. Performing the depressurization quickly helps with mixing, which improves removal of hydrocarbon from the vessel so that fewer overall cycles of purging and depressurization are needed. This is scheduled as part of the IMPACT planning process. See Section 5.1.6 for the IMPACT process. Clean-up activities are planned and scheduled as part of the IMPACT planning process to minimize impacts of nitrogen flows to the relief system.

### **General**

For connected flare systems, such as in the refinery's North Yard Flare Gas Recovery System, plant areas generating relief gases that cannot be recovered can be isolated from the rest of the flare gas recovery system. By isolating a plant area, and diverting only that flow to a flare, gases from other plant areas can continue to be recovered for treatment and use in the refinery's fuel gas system.

### 5.1.6 Turnaround and Maintenance Flare Minimization Planning Tool

The Richmond Refinery's existing flare planning process has been expanded to incorporate a broader range of planned refinery activity, which includes short term planned maintenance. The expanded scope of the relief planning process captures additional opportunities for flare minimization. Lessons learned to minimize flaring are captured and considered during future planned turnaround and maintenance events.

Per the IMPACT planning process for maintenance turnarounds a flare plan is prepared as part of the turnaround planning process. This plan identifies a schedule of discrete work steps such as pulling feed, shutting down, depressuring, and cleaning up units and equipment that could generate flare gas to relief. Impacts to the relief system are predicted and estimated by using parameters such as sulfur content, flow rate and duration. A most-likely case and worst-case scenario is usually developed for each step having an impact. Consideration is given to whether relief gases can be recovered or routed to another location besides relief. Whenever applicable, the depressurization / purging duration and rate are decreased to keep the vent gas flow under FGR capacity.

The development of flare plans under IMPACT SCS Task No. 27 is joint effort between the turnaround Operations Coordinator, Plant Process Engineer, and the IMPACT Planner. The improvements to this procedure are shown in figure 5-1 and listed in table 4-1.

Inputs into the plan include:

- Major operating steps involving depressuring or relieving equipment to relief, nitrogen purging to the flare and shutdown/startup of flare gas recovery systems.
- Environmental or regulatory limits and internal guidelines and limits for depressuring equipment to relief or operation of the flares.
- Current sources and typical rates of gas to the relief system, current typical Flare Gas Recovery system rates and total FGR system capacity.
- Expected post-shutdown sources and typical rates of gas to the relief system, expected FGR system rates, and expected FGR system capacity.

Plan outputs include a schedule of all equipment depressured to flare during shutdown, clean-up and start-up of the unit. The plan shall meet all regulatory and management limits on depressuring equipment to relief and operation of the flare. The schedule is routed to Environmental and Process Engineering Groups as needed.

The IMPACT process for planning major maintenance turnarounds includes a "lessons learned" session to incorporate learnings into the next subsequent turnaround. The Refinery has developed a process to formalize the "lessons learned" process in order to capture and document learnings. This process happens approximately 18-24 months before pulling plant feed. Lessons learned can include the considerations for recovery in Section 5.2.4.

### 5.1.7 Measures to Minimize Flaring During Unplanned Maintenance

There are occasions, primarily as a result of equipment malfunction, where a relatively immediate decision is made to shutdown a block of the refinery, typically within a period of days, allowing little time for the kind of specific planning used for turnarounds and planned maintenance. In these cases, it is often not possible to make the same level of plant adjustments necessary to minimize flaring to the extent possible when a shutdown is planned far in advance. Despite this, there are actions that can be taken to minimize flaring even when there is very little advance notice. For these cases, the refinery utilizes general procedures to minimize flaring for unplanned events, as shown in Figure 5-1. Although there is less of an opportunity for scheduling shutdown procedures so as to insure that there will be a home for all of the gas generated at each step of the process, many of the same general principles apply

when the decision to bring the unit down is immediate. A flowchart of the Richmond Refinery's Flare Planning process is shown below, in Figure 5-1. This flowchart identifies aspects of the existing process, and highlights areas that will be updated.

Figure 5-1, Flare Planning Process Flowchart

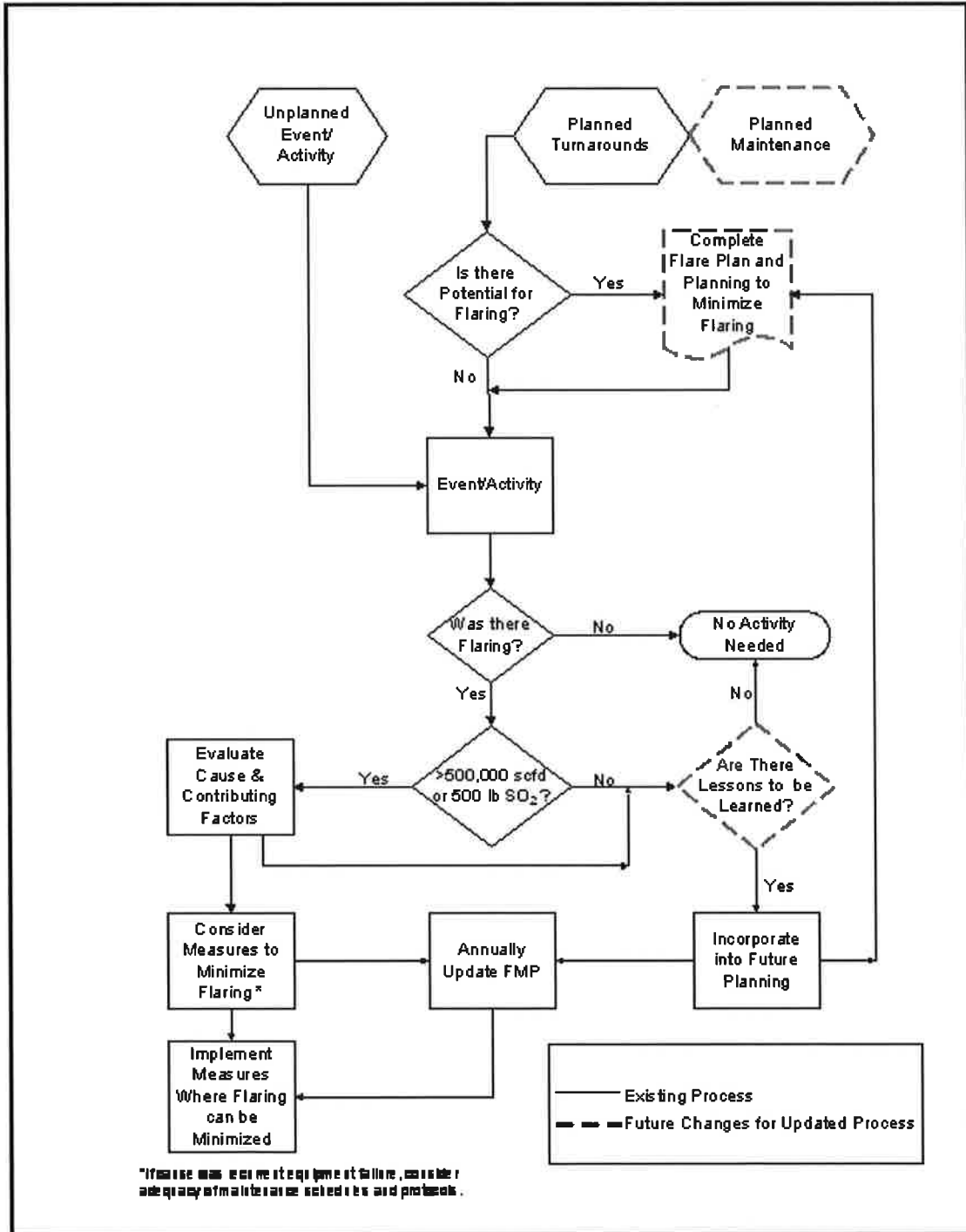

## 5.2 Gas Quality and/or Quantity Issues

Pursuant to the requirements of Regulation 12, Rule 12, Section 401.4.2, this section provides a description and evaluation of prevention measures for flaring that may reasonably be expected to occur due to issues of gas quantity or quality. The section includes information on when flaring is likely to occur, as well as a discussion of the refinery's systems for recovery of relief gases. An evaluation of options for increased recovery, storage, and treatment of gases is also presented.

Fuel gas is generated in varying quantity and quality from the following process units: FCC; TKC; TKN; ISO; LNF; HNF; RLOP; FGR; NHT & JHT. All of these gas streams have high H<sub>2</sub>S content, and these streams are scrubbed to remove the H<sub>2</sub>S before they are sent to the refinery fuel gas (RFG) header. The Refinery has two separate, but interconnected, fuel gas headers are operated that serve the two main process areas, North Yard and South Yard. RFG is used as feed to the Hydrogen trains or as refinery fuel in process heaters on the units and the Cogen.

RFG is a mixture of natural gas and sweetened process gas from the refinery H<sub>2</sub>S Plants and vaporized LPG (primarily C<sub>4</sub>). The following composition and characteristics are approximately typical of RFG:

Hydrogen	14.0
Methane	58.8
Propane	8.0
Butane	9.0
C <sub>5</sub> +	1.0
Nitrogen	3.0
CO <sub>2</sub>	0.2
High Heating Value	1,100 Btu/SCF
Low Heating Value	1,000 Btu/SCF
Specific Gravity	0.67
H <sub>2</sub> S Content	160 ppm max

The quantity and quality of the fuel gas will vary depending on the type of crude oil being processed, the severity of operations, and the relative contributions from the various process units at any one time.

In normal operations, the RFG is supplemented with fuel from both natural gas (NG), Medium BTU Gas (MTG) and Liquid Petroleum Gas (LPG). The blend of these supplementary fuels depends on the heat content of the RFG, the refinery demand, and the supplies of material from these other sources. Because in normal mode there is not sufficient RFG thermal heating value for all users, and as a safety provision that critical equipment is not solely dependent on a single fuel source, it is necessary to supplement the RFG with imported natural gas (NG).

Fuel gas drums are monitored for heating value, specific gravity, pressure and H<sub>2</sub>S on a continuous basis. Hourly averages for heating value, specific gravity and pressure are reviewed on a daily basis. All fuel gas drums alarm if the instantaneous value of the H<sub>2</sub>S reaches 50 ppm. Computer monitoring analyzes and adjusts the RFG, NG, MTG, and LPG continually to maintain an efficient balance. Maintaining the right RFG composition is critical from an efficiency and safety perspective, as:

- Not optimizing RFG use means either importing extra NG or vaporizing valuable LPG product.

- Having too much RFG with low heating value content (such as H<sub>2</sub>, N<sub>2</sub> or CO<sub>2</sub>) can lead to severe operational problems that include flame instability, operating equipment outside the manufacturer's suggested operational range for the burners, flame lift off forcing a plant shutdown, incomplete combustion causing high CO and hydrocarbon situations, and in worse case scenarios, detonation of un-burnt hydrocarbons in the furnace. An unplanned, emergency shutdown due to RFG with an overall heating value that is too low is an unacceptable risk because it causes additional flaring during a plant shutdown as well as exposes personnel to an unacceptable operating condition in the furnace boxes.
- Increased quantity of RFG with low heating value content can lead to poor flame patterns, causing potential reliability issues such as burner wear or tube impingement.

### 5.2.1 When Flaring is Likely to Occur due to Gas Quality/Quantity Issues

Richmond Refinery has identified situations or activities likely to cause flaring, as described below in more detail. Releases of relief gas to the flare result from an imbalance between the quantity of vent gas produced by the refinery and the rate at which it can be compressed, treated to remove contaminants (sulfur compounds) and utilized as fuel gas. Situations that can lead to flaring can be grouped together based on similarity of cause. These general categories, including some specific examples of events which fit into each category, are outlined and discussed below:

#### Maintenance Turnaround, Startup and Shutdown

To prepare an individual equipment item or a block of refinery equipment for maintenance, it is necessary to isolate it from active operations and clear it of process fluids. Examples include:

- Unit shutdowns
- Working on equipment and/or relief systems
- Catalyst change
- Plant leak repairs
- Compressor maintenance or repairs

In order to avoid flaring there must be a balance between producing and consuming fuel gas units. When either a block of equipment or an individual equipment item is removed from service, if it either produces relief gases or consumes fuel gases, then the balance of the fuel gas system is changed and adjustments are necessary to bring the system back into balance. If the net change in gas production or consumption is large and the adjustments in the rate at which gas is produced or consumed by other units cannot be made quickly enough, then flaring results. Examples include:

- Hydrogen Plant (Furnaces) Shutdown
- Startup of the TKN/ISO Gas Recovery Unit
- Startup of FCC unit and/or shutdown of the Alkylation unit

Additionally, in order to clear hydrocarbons from equipment in a safe and controlled manner prior to performing maintenance, a variety of procedures must be used. These procedures can change the quantity and quality of fuel gas produced. Examples include:

- Depressurization of equipment
- Pressurization of equipment with nitrogen to remove hydrocarbon resulting in low fuel value (high nitrogen content) gas which cannot be used with burners designed for "normal" flare gas, as NO<sub>x</sub> issues with low Btu gas.



### Upset/Malfunction

An imbalance in the flare gas system can also result from upsets or equipment malfunctions that either increase the volume of flare gas produced or decrease the ability of the fuel gas handling system to accommodate it. Examples include:

- Leaking relief valves
- Pressure Relief Valve malfunction
- Equipment overpressure or other cause for relieving relief valves
- Equipment Plugging resulting in local overpressure
- Loss of a major process unit compressor (e.g., FCC wet gas compressor)
- Loss of fuel gas recovery system compressors
  - Reciprocating compressor seats overheating from high nitrogen or hydrogen content
  - Fuel gas with low specific gravity, or high heat of compression resulting in overheating
  - High inlet temperature to flare gas compressor
  - General mechanical problems from the operation of rotating equipment.
- Loss of a utility (steam, cooling water, power)
- Loss of air fins or condensers

### Emergencies

Pursuant to Regulation 12, Rule 12, Section 201, an emergency "is a condition at a petroleum refinery beyond the reasonable control of the owner or operator requiring immediate corrective action to restore normal and safe operation that is caused by a sudden, infrequent and not reasonably preventable equipment failure, natural disaster, act of war or terrorism or external power curtailment, excluding power curtailment due to an interruptible power service agreement from a utility."

### Other Causes

There are many potential other causes of flaring which cannot be eliminated, despite careful planning and system design to minimize the risk of their occurring. Some examples of these types of other causes include:

- Sudden, infrequent and not reasonably preventable equipment failures
- Shutdown
- Start-up
- Acts of God
- Terrorism

## **5.2.2 Vent Gas Recovery Systems**

Refinery unit operations both produce and consume light hydrocarbons. Most of these hydrocarbons are routed directly from one refinery process unit to another. Refineries are constructed with a network of relief gas headers running throughout each of the process units in order to allow collection and safe handling of any hydrocarbon vapors that cannot be routed directly to another process unit. The hydrocarbon vapors are collected at low pressures in these relief gas headers. These gases are recovered for reuse by increasing their pressure using a flare gas compressor system. The compressed gases are typically returned to the refinery fuel gas system for use in fired equipment within the refinery. Any gas not compressed and sent to the fuel gas system is routed to a flare so it can be disposed of safely by combustion under controlled conditions. A typical flare gas system was shown at the beginning of this document, in Figure 1-1. Schematic diagrams of the specific flare gas recovery systems in place at the Richmond Refinery are provided in Appendix A.

The capacity of a flare gas recovery system is functionally the total capacity of the FGR compressors (aside from spares). As long as the FGR load does not exceed the capacity of the current FGR compressors, and the compressors are reliable, there is no benefit to running spare compressors or installing larger machines, as is shown on Table 5-3. Where spare units are provided that are not operated simultaneously, the spare capacity is not included as a part of total system capacity. Flare gas compressor capacity does not fully define the total capacity of the system in all cases, however. In order to recover flare gas for use in the fuel gas system, three criteria must be met. First, there must be sufficient flare gas compressor capacity. Second, there must be sufficient gas treating capacity. Finally there must either be available storage volume or a user (e.g., fired heater) with a need for the gas. If any of these conditions are not met, then the gas cannot be recovered into the fuel gas header.

**5.2.3 Existing Systems for Vent Gas Recovery**

Within the Richmond Refinery, the systems that currently exist for recovery and treatment of vent gases, and the typical scenario for their use, are described in Table 5-2 below.

**Table 5-2 Flare Gas Recovery System Capacities**

<i>Flare System</i>	<i>Vent Gas Recovery (Compressor) Capacity (MMSCFD)</i> Notes 3,4	<i>Storage Capacity (MMSCF)</i>	<i>Amine Plant Inlet Capacity (MMSCFD)</i> Note 5	<i>Sour gas production from process units (MMSCFD)</i> Note 6	<i>(Amine plants) Scrubbing Capacity for Vent Gas (MMSCFD)</i>
North Yard – #3H2S Plant	n/a	n/a	25	25	0
North Yard – #4 H2S Plant	8	n/a	25	45	0
North Yard – #6 H2S Plant	Note 7				
South yard – #5H2S Plant	2 - 6	n/a	40	10	10
Totals	10 - 14	n/a	90	80	10

Note 3: Where spare equipment has been installed, the capacity shown is exclusive of the installed spare equipment and includes only the capacity that can be achieved when all equipment which could reasonably be operated simultaneously is online.

Note 4: The South Yard Flare Gas Recovery System has the option to put K-1171/K-1171A and K-242/252 compressors into service to augment capacity of the main K-3950 Flare Gas Recovery Compressor.

Note 5: The Amine (H2S Treating) plants are also subject to, and may be limited by, Title V back-end throughput limits on the volumetric rate of H2S production.

Note 6: This column shows typical sour gas production rates. Note that the North Yard can export up to 20 MMSCFD sour gas to the South Yard and process this gas in the #5 H2S Plant.

Note 7: #6 H2S Plant is part of the Richmond Refinery Energy and Hydrogen Renewal Project, which was postponed by legal action. The Environmental Impact Report (EIR) for the project is currently being revised. A timeline for re-starting project implementation is not known at this time.

The Richmond Refinery vent gas recovery system does not include any dedicated capacity for storage of fuel gas or vent gas. However, on a continuous basis the refinery optimizes the refinery fuel gas system of producing and consuming units to maximize the capacity available for treatment and reuse of recovered gases by employing the following strategies:

- adjusting the sources of fuel that are made up to the fuel gas system including imported natural gas, propane, and butane;

- adjusting the operations of units that produce fuel gas range materials including at times reducing severity of operations to reduce fuel gas production if it places the refinery in a flaring situation; and
- adjusting the refinery profile for consumption of fuel gas by ensuring that fuel gas consuming units and/or equipment are being used to full extent possible, e.g., shifting rotating equipment to turbine drivers where available as spares (which operate with steam generated in the fuel gas fired boilers).

The total gas scrubbing capacity that is indicated is an integral part of the refinery fuel gas management system. This capacity is closely matched with the fuel gas consuming units (e.g., heaters, boilers, etc.) usage requirements. The capacity indicated as being available for recovered vent gas scrubbing will vary depending on the balance between fuel gas production and consumption; it will vary both on a seasonal basis and during the course of the day. For this reason the table above provides the approximate nominal available capacity.

With this system for flare gas recovery in place, the combined daily average flow recovered by the North and South Yard Flare Gas Recovery Systems was 5.27 MMSCFD during the 2005 calendar year, equivalent to an annualized total of approximately 1923 MMSCF per year. The total of vent gases flared during the 2005 year was approximately 142 MMSCF. This shows that the vent gas recovery system effectively recovered and reused 93% of the volume of gases routed to the relief gas headers.

#### 5.2.4 Options for Recovery, Treatment and Use

To address the requirements of Regulation 12, Rule 12, Section 401.4, the Richmond Refinery has considered the feasibility of further reducing flaring through additional recovery, treatment, and/or storage of relief gas header gases, or through other means to use the recovered gases. This evaluation considers the impact these additional systems would have on the volume of flared gases remaining in excess of what has already been recovered (as noted in the previous section), and the associated mass flow of hydrocarbons emitted after combustion in the flare control device.

A typical relief gas header is connected to both a flare gas recovery system and to one or more flares. Normally all vapor flow to the relief gas header is recovered by a flare gas recovery compressor, which increases the pressure of the flare gas allowing it to be routed to a gas treater for removal of contaminants such as sulfur and then to the refinery's fuel gas system. Gas in excess of what can be handled by the flare gas recovery compressor(s), the treater(s), and/or the fuel gas system end users flows to a refinery flare so it can be safely disposed of by combustion. Therefore, in order to reduce the volume of gas flared, three essential infrastructure elements are required: sufficient compressor capacity to increase the pressure of the gas to the point where it can be used in the refinery fuel system, sufficient storage volume to dampen out the variation in volumetric flow rate from the relief gas header, and sufficient capacity in treating systems to condition the gas (primarily by removal of sulfur) for use in the fuel gas system.

Many types of systems are used for compression of flare gas. Options include centrifugal, reciprocating, and rotary compressors, as well as liquid jet ejectors. Each of these options has advantages and disadvantages that lead to it being better suited for use under certain sets of conditions. Centrifugal compressors generally have low maintenance requirements, but are more sensitive to variation in gas properties (e.g., molecular weight) than a reciprocating machine is. Reciprocating compressors, although designed to operate best with a gas that has a specific molecular weight, can operate with a range of compositions so long as inter-stage temperature limits (300 – 350°F is typical) are not exceeded. The rule-of-thumb maximum practical capacity for a single reciprocating compressor is about 4 MMSCFD of gas at the compressor inlet. Rotary screw compressors are less expensive, but generally less reliable than other options. Liquid ring compressors are less efficient than most reciprocating or

centrifugal machines, and cannot achieve as high an outlet pressure, however they have a high tolerance for variation in composition, including some liquid. They are less likely to go into surge than centrifugal or reciprocating compressors. Liquid jet ejectors are very reliable; as they have no moving parts in contact with the gas stream. They can handle a rapidly varying vapor load, but are much less efficient than other types of compressors, so have high power requirements as a result.

Options for storage of flare gas are analogous to those for storage of other process gases. Gases can be stored at low pressure in expandable gas-holders with either liquid (water) or dry (fabric diaphragm) seals. The volumes of these systems expand and contract as gas is added or removed from the container. Very large vessels, containing up to 10,000,000 cubic feet of gas can be constructed by using multiple "lifts", or stages. Gases can also be stored at higher pressures, and correspondingly lower volumes, in steel bullets or spheres. The optimal pressure vessel configuration depends on system design pressure and total required storage volume.

For any type of gas storage facility, selection of an acceptable site and obtaining the permits necessary for construction both present difficulties. Despite the refinery's demonstrated commitment and strong track record with respect to safe handling of hazardous materials, there are always concerns about any plan calling for the storage of large volumes of flammable gas containing hydrogen sulfide and other sulfur compounds. Safety concerns are expected to impact site selection as well. Although the objective of the project would be a reduction in flaring, there are expected to be multiple hurdles along the path to a construction/land use permit.

The fact that flare gas is flammable creates safety concerns if large volumes are to be stored. A 60 ft diameter storage sphere filled with flare gas at 140 psig carries with it significant risks if the gas escapes and is ignited. Combustion of flammable gases as they are produced, either in process equipment or in a flare system, is intrinsically safer than storage, as it minimizes the onsite inventory of combustible material. The minimization of on-site storage of combustible gases also addresses Homeland Security concerns.

Flare gas treating is used to condition flare gas for use as fuel in the refinery fuel gas system. Treatment is focused on removal of sulfur compounds, with some systems improving fuel value by removing carbon dioxide as well. A range of technology options exist, most of which are based on absorption of acid gases into a "lean" amine solution (MEA, DEA, MDEA, DGA) with regeneration of the resulting "rich" solution by stripping at lower pressure. In order to recover additional fuel gas it is necessary to have sufficient capacity to match the capacity of gas treating systems to the peak flow rate of the flare gas requiring treatment.

### **5.2.5 Evaluation of Options for Additional Capacity**

In order to assess the potential effect of additional flare gas recovery at the Richmond Refinery, a hypothetical design for an upgraded system was developed. This design considers options separately for each of the North Yard and South Yard Flare Gas Recovery Systems, since they are independent within the Richmond Refinery. The impact that the hypothetical design would be expected to have on hydrocarbon emissions, based on the refinery's recent flaring history, was then evaluated from an emissions reduction and cost effectiveness point of view.

A simplified diagram of the hypothetical design is shown in Figure 5-2. The diagram in Figure 5-2 highlights differences from the typical Flare Gas Recovery System shown previously in Figure 1-1. Results of this evaluation are provided for two system capacities for the North Yard Flare Gas Recovery System, and two system capacities for the South Yard Flare Gas Recovery System.

Figure 5-2, Flare Gas Recovery System with Additional Capacity

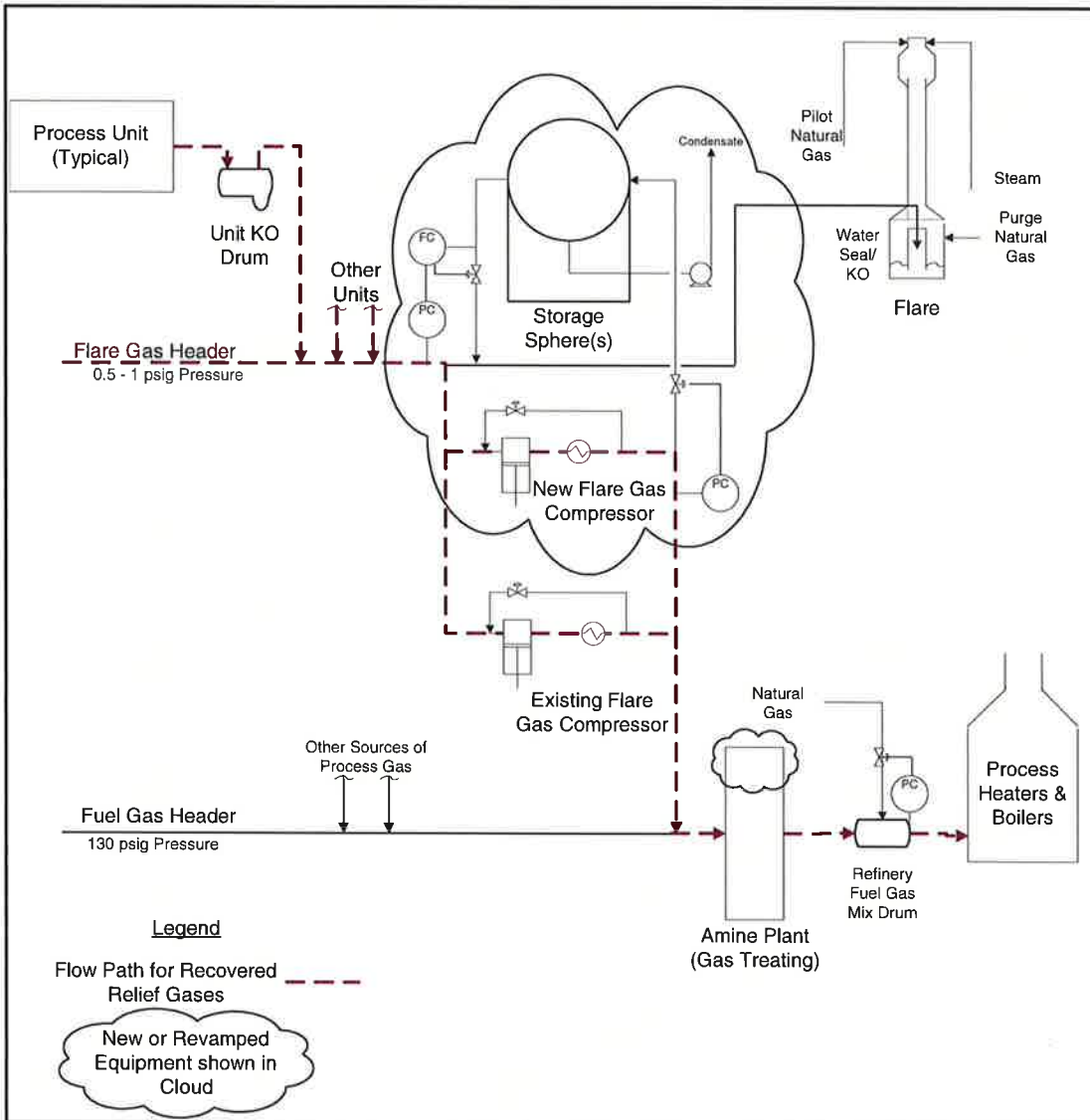

Basis for Evaluation:

A few specific cases for changes to the refinery's capacity to recover relief gases were evaluated. The cases evaluated correspond to several increments of additional capacity for recovering relief gases, the major equipment installations required to achieve that recovery, and the estimated total installed cost for the additional equipment. Budgetary level (order of magnitude) cost information for each of the cases evaluated is shown in Table 5-3.

**Table 5-3 Capital Cost Estimates for Increased Recovery Capacity** (Note 8)

<i>Additional Vent Gas Compressor Capacity</i>	<i>Costs of Additional Vent Gas Compressor Capacity</i>	<i>Costs of New Surge Storage (24 hrs at Flow rate)</i>	<i>Costs of Additional Gas Treating Capacity (at indicated Flow rate)</i>	<i>Total for Additional Compressor, Storage and Treating Capacity</i>
1.0 MMSCFD	\$ 3,400,000	\$ 2,500,000	\$ 800,000	\$ 6,700,000
2.0 MMSCFD	\$ 5,000,000	\$ 4,500,000	\$ 1,700,000	\$ 11,200,000
4.0 MMSCFD	\$ 6,700,000	\$ 10,000,000	\$ 3,200,000	\$ 19,900,000

Note 8: All values indicate estimated total installed capital cost. Estimates based on total installed cost data from similar installations where available. Otherwise, vendor quotes, in combination with standard industry cost estimation procedures, have been used to estimate system cost.

Each case evaluated is based on the need for installation of three major systems in order to increase recovery of flare gases from current levels:

#### Additional Vent Gas Compressor Capacity

This cost is based on providing additional compressor capacity to recover vent gas flowing in the relief gas header in excess of current existing compressor capacity. The additional capacity would be used for transfer to storage and/or treatment. Costs provided are for one un-spared reciprocating compressor system to be added to the existing main relief gas header.

#### New Surge Storage

This cost is based on providing temporary surge storage for a portion of the gases routed to the relief gas header in excess of the volumes currently being recovered, treated, and consumed. The addition of temporary surge storage volume is necessary for any further increase in flare gas recovery capacity, since it allows for flare gas flow (which is highly variable) to be balanced with the demand for fuel gas. The cost used is based on a storage volume equal to the total volume of gas accumulated over one day at the identified flow rate, and is based on recovery in a high pressure sphere system capable of discharging directly back into the refinery fuel gas system. Other lower pressure approaches were considered (low pressure gas holder, medium pressure sphere), but for the sizes analyzed a high pressure sphere was identified as the technically preferred approach based on operational, safety and economic considerations.

#### Additional Gas Treating Capacity

The cost of additional amine-based treating capacity to process recovered gases for sulfur removal so that they can be burned by existing fuel gas consuming units without exceeding environmental or equipment operational limits. Installed cost data for new treatment systems was scaled to estimate the cost of adding additional treatment capacity to the refinery's existing treatment systems.

North Yard Flare Gas Recovery (FGR) System Evaluation:

The North Yard flares are tied into a single FGR system which is evaluated in this section.

- Sampling data from reportable flaring events has been reviewed, identifying that the hydrocarbon content in the flared gases has ranged from 20% to 90% (as propane), with an average value of 62%. This average hydrocarbon content value corresponds to 0.07 lbs of hydrocarbon in each standard cubic foot (SCF) of flared gas. Applying 98% efficiency for the flare combustion device, this corresponds to 0.0014 lbs of hydrocarbon emissions per SCF of vent gas flow sent to the flare.

- The daily average flaring data has been reviewed for the previous calendar year (2005) leading to the conclusion that, on an annual basis, the addition of 2 MMSCFD of additional (un-spared) compressor system (including storage and treating) capacity would capture approximately 52 MMSCFD of gases currently flared. This evaluation has been performed by totalizing the volume of gas currently routed to the flare that could be captured by a system with a flow capacity of 2 MMSCFD. Daily data for flow to the North Yard Flares was used for the evaluation. Flow in excess of the 2 MMSCFD rated compressor capacity cannot be recovered by this system.

- A similar evaluation has been performed to determine the impact of adding 4 MMSCFD additional flare gas compressor system capacity. This would result in the capture of an additional 62 MMSCFD of flared gases on an annual basis.

- Applying the average gas composition and the lb hydrocarbons emitted per SCF of flared gas factor to the identified reduction in flared gas volumes, maximum possible reduction in hydrocarbon emissions if all 2005 flared emissions were captured was estimated at 73,161 lb/year for 2 MMSCFD additional flare gas compressor capacity and 86,859 lb/year for 4 MMSCFD additional flare gas compressor capacity.

- Using the emission estimates above, with cost estimates from the table above (annualized per the BAAQMD BACT workbook), annual operating cost estimates, and AP42 emission factors and other engineering estimates, the cost effectiveness for 2 MMSCFD additional flare gas compressor capacity was estimated at:

- \$86,000 per ton of non-methane hydrocarbon (NMHC) reduced, or
- \$39,000 per ton of SO<sub>2</sub> reduced, or
- \$235,000 per ton of CO reduced, or
- \$1.3 MM per ton of NO<sub>x</sub> reduced, or
- \$9.2 MM per ton of soot reduced.

Similarly, the cost effectiveness for 4 MMSCFD additional flare gas compressor capacity was estimated at:

- \$119,000 per ton NMHC reduced, or
- \$53,000 per ton of SO<sub>2</sub> reduced, or
- \$325,000 per ton of CO reduced, or
- \$1.8 MM per ton of NO<sub>x</sub> reduced, or
- \$12.7 MM per ton of soot reduced.

These estimates significantly exceed the \$20,000/ton NMHC emission reduction BAAQMD threshold for cost effectiveness referenced in the District's staff report for 1997 amendments to BAAQMD Rule 8-28.

- An additional factor that would severely limit the reduction in emissions such a recovery system would achieve in practice is the capability of the fuel gas consumers to accept these gases at the time at which they are generated (from both a volume and quality perspective).

#### South Yard Flare Gas Recovery (FGR) System Evaluation:

The South Yard flare (LSFO flare) is tied into a single FGR system which is evaluated in this section.

- Sampling data from reportable flaring events has been reviewed, identifying that the hydrocarbon content in the flared gases has ranged from 9% to 100% (as propane), with an average value of 16%. This average hydrocarbon content value corresponds to 0.07 lbs of hydrocarbon in each SCF of flared gas. Applying 98% efficiency for the flare combustion device, this corresponds to 0.02 lbs of hydrocarbon emissions per SCF of gas flow to the flare.
- The daily average flaring data has been reviewed for the previous calendar year (2005) leading to the conclusion that, on an annual basis, the addition of 1 MMSCFD of additional (un-sparged) compressor system (including storage and treating) capacity would capture approximately 6.4 MMSCF of gases currently flared. This evaluation has been performed by totalizing the volume of gas currently routed to the flare that could be captured by a system with a flow capacity of 1 MMSCFD. Daily data for flow to the South Yard Flare (LSFO Flare) was used for the evaluation. Flow in excess of the 1 MMSCFD rated compressor capacity cannot be recovered by this system.
- A similar evaluation has been performed to determine the impact of adding 2 MMSCFD additional flare gas compressor system capacity. This would result in the capture of an additional 8.1 MMSCF of flared gases on an annual basis.
- Applying the average gas composition and the lb hydrocarbons emitted per SCF of flared gas factor to the identified reduction in flared gas volumes, maximum possible reduction in hydrocarbon emissions if all 2005 flared emissions were captured was estimated at 2,297 lb/year.
- Using the emission estimates above, with cost estimates from the table above (annualized per the BAAQMD BACT workbook), and annual operating cost estimates, the cost effectiveness was estimated at \$1,687,000/ton NMHC reduced for 1 MMSCFD additional flare gas compressor capacity and \$2,038,000/ton NMHC reduced for 2 MMSCFD additional flare gas compressor capacity. These estimates significantly exceed the \$20,000/ton emission reduction BAAQMD threshold for cost effectiveness referenced in the District's staff report for 1997 amendments to BAAQMD Rule 8-28.
- An additional factor that would severely limit the reduction in emissions such a recovery system would achieve in practice is the capability of the fuel gas consumption units to accept these gases at the time at which they are generated (from both a volume and quality perspective).

#### Conclusions:

Based on this review and the high efficiency of the present system the Richmond Refinery has concluded that further expansion of systems for the recovery, treatment and use of flared gases is neither a cost effective nor feasible approach to reducing these emissions. The Richmond Refinery and general industry practices have identified that the major source of flared gases on a volume basis can be attributed to large flow rate flaring events, especially those of extended



duration such as may occur during emergency events or prolonged shutdowns where systems within the refinery are out of fuel gas (and / or hydrogen) balance.

The Richmond Refinery has allocated significant resources to the development of procedures to plan for, manage, and minimize large flow and duration flaring events. Further resources have also been allocated effectively to ongoing preventive maintenance programs, and even to adjust refinery operations on a severity and throughput basis. These approaches have been identified to be more effective than providing additional flare gas recovery system capacity.

#### **5.2.6 Preventing Production of Low-Quality Fuel Gas**

Measures to help prevent production of low-quality fuel gas, (e.g., sour gas, low Btu gas, high nitrogen content) are further investigated in this section. The discussion is integrated with the discussion of turnaround and maintenance events as gas quantity (insufficient demand) and gas quality (unscrubbed during upset/malfunction and nitrogen/steam during turnaround) are the primary drivers for flaring during these events. It is for this reason that the measures used to minimize production of low quality fuel gas are closely related to those that can be applied to reduce flaring during maintenance and turnaround events.

Preventing production of sour fuel gas is accomplished by making sure that recovered flare gas is routed to the fuel gas system via a gas treating system. It is preventing the production of sour fuel gas that drives the need to match the capacity of treating systems to accept flare gas to flare gas recovery capacity.

High fuel gas nitrogen levels are primarily caused by the nitrogen used to purge hydrocarbons from equipment in preparation for equipment opening. High nitrogen fuel gas content is controlled by limiting the rate at which nitrogen is introduced to equipment and ultimately the flare gas system during nitrogen purging operations. There can be a trade-off between nitrogen flow rate and the effectiveness with which the nitrogen mixes within the contents of the vessel from which hydrocarbons are being removed. These must be balanced on a case-by-case basis to determine the purge rate that represents the best compromise among competing process needs.

#### **5.2.7 Minimizing Sulfur Emissions from Flaring**

Historical changes and planned improvements to reduce flaring that were included in Tables 3-1 and 4-1 have had an overall effect of reducing the amounts of hydrocarbons sent to flares, and a corresponding reduction in the amount of sulfur compounds released. The cycle of refinery turnarounds can cause the overall emissions from flares to vary over time, which will likewise affect emissions of sulfur compounds. The flare planning process as described in Section 5.1.6 is a primary means to reduce emissions of sulfur compounds by minimizing flaring activity.

Causal analyses performed for releases of sulfur compounds have generated some of the historical changes and planned improvements to reduce flaring included in Tables 3-1 and 4-1.

The cascading of North Yard flares described in Section 2.1 is another means by which releases of sulfur compounds are minimized.

Additionally, all flare vent gases that can be recovered by the FGR compressors are sent to the Refinery's H<sub>2</sub>S plants for removal of H<sub>2</sub>S so that the gas can be used as refinery fuel gas. All flare gas generated by planned operations is recovered by the FGR compressors except when high nitrogen, steam or hydrogen content would cause overheating of the compressors. FGR compressors have been upgraded to increase their capability to handle these conditions.

### 5.3 Recurrent Failure

This section provides information on prevention measures for flaring caused by the recurrent failure of air pollution control equipment, process equipment, or a process to operate in a normal or usual manner. Pursuant to Regulation 12, Rule 12, Section 401.4.3, a failure is recurrent if it occurs more than twice during any five year period as a result of the same cause as identified by cause investigations conducted pursuant to the requirements of Regulation 12, Rule 12, Section 406 (i.e., after July 20, 2005).

The Richmond Refinery has in place a preventative maintenance program that is consistent with recognized industry standards and recommended practices (e.g., American Petroleum Institute 520). This program includes procedures and policies to maintain the reliability equipment so that equipment failures and other types of process upsets are minimized or eliminated. When equipment or systems do fail and impact operations (or cause significant flaring), investigations are conducted to identify the cause of the failure and implement suitable corrective actions. The flowchart shown previously in Figure 2, which illustrated the investigative process for planned and unplanned maintenance events, is also followed when equipment fails or processes experience upsets.

The Richmond Refinery has identified one instance where more than one flaring event was related to the same identified cause. Information on this flaring is shown in Table 5-4, organized by flaring event date.

**Table 5-4 Reportable Flaring Events Attributable to the Same Equipment Item  
For the Period beginning July 20, 2005**

<i>Date(s)</i>	<i>Process or Equipment Item</i>	<i>Comments</i>
1/11/06	LSFO Flare (S-6010)	Flaring was caused by the shutdown of the K-3950 Flare Gas Recovery (FGR) compressor to perform maintenance. The K-3950 compressor was shut down to perform maintenance due to a buildup of abrasive ammonium chloride salts inside the compressor. The source of the salts in the refinery's South Yard plant relief system has not yet been determined.
1/24/06	LSFO Flare (S-6010)	Flaring caused again by shutdown of the K-3950 Flare Gas Recovery (FGR) compressor to perform maintenance due to buildup of ammonium chloride salts in the compressor.

Consistent with the refinery's procedures for investigating equipment failures and other incidents, corrective actions were implemented in response to the first instance of flaring (on January 11, 2006). Since the root cause (i.e., the source of the ammonium chloride salts in the South Yard relief system) was unknown, the primary corrective action from the investigation was to identify the source of the salts and develop a list of potential measures for their elimination from the relief system.

An extensive sampling effort was conducted to evaluate potential sources of chlorides into the relief system. It was determined that the source of chlorides into the relief system was caused by blowing down perchloroethylene lines to relief during steps in the catalyst regeneration process for the Rheniformers. To reduce this source of chlorides, the 5 Rheniformer Regen Procedure was revised to lessen the amount of perchloroethylene that is purged to relief during

the regeneration process. The Richmond Refinery is currently in the process of permitting carbon filter canisters to capture perchloroethylene and prevent it from entering the relief system (see Table 4-1).

Within a few weeks of the first event date, while the investigation for the initial cause was still in progress, a second instance of flaring occurred (on January 24, 2006), and was later identified as being due to the same cause. The Richmond Refinery was addressing this issue with BAAQMD to understand how to classify situations where additional flaring occurs while it is still investigating the cause and/or a corrective action from the initial instance is still in the process of being implemented. Additional preventative maintenance measures were developed in the interim to supplement the refinery's existing program for preventative maintenance on flare gas recovery compressors. These included development of a new water wash procedure for K-3950 Flare Gas Recovery Compressor, which removes salts from the compressor's internal parts, and is intended to minimize wearing and/or damage to the compressor that might lead to more lengthy repairs. An additional benefit of the procedure is that it helps maintain compressor capacity, which can be reduced when material builds up on compressor internals. The water wash procedure was performed successfully on a trial basis in April 2006, and is due to be incorporated into standard plant maintenance procedures as necessary. In August, 2007, two carbon drums in series were installed on the bulk storage perchloroethylene drum (V-3592) off gas line to minimize formation of salts in the south yard relief system. Operating procedures have been revised and operator crews have been trained to follow these procedures.

Between June 2008 and June 30, 2009, there were no flaring activities which required causal analyses that were due to the same causes.

#### **5.4 Other Potential Flaring Events**

The flowchart shown in Figure 5-1 covers the range of potential flaring events that the refinery might experience.

## Appendix A – Simplified Flow Diagrams Chevron Richmond Refinery Flare Systems

This section included in Trade Secret Transmittal  
Submitted under separate cover

### **Trade Secret Information**

Drawings in this Appendix are trade secrets of Chevron Products Company as defined in California Public Records Act, Section 6254.7 of the Government Code. The information shown in these drawings reveals information about the refinery's operation that could harm Chevron's competitive market position. Because of the sensitive and competitive nature of the information, Chevron Products Company requests that the BAAQMD afford the information Confidential Business Information treatment indefinitely. These drawings are not subject to public disclosure as a public record without the express written consent of Chevron Products Company.

## Appendix B – Flare P&IDs

### Chevron Richmond Refinery Flares

This section included in Trade Secret Transmittal,  
Submitted under separate cover.

#### **Trade Secret Information**

Drawings in this Appendix are trade secrets of Chevron Products Company as defined in California Public Records Act, Section 6254.7 of the Government Code. The information shown in these drawings reveals information about the refinery's operation that could harm Chevron's competitive market position. Because of the sensitive and competitive nature of the information, Chevron Products Company requests that the BAAQMD afford the information Confidential Business Information treatment indefinitely. These drawings are not subject to public disclosure as a public record without the express written consent of Chevron Products Company.

## Appendix C – Flare Elevation Drawings Chevron Richmond Refinery Flares

This section included in Trade Secret Transmittal,  
Submitted under separate cover.

### **Trade Secret Information**

Drawings in this Appendix are trade secrets of Chevron Products Company as defined in California Public Records Act, Section 6254.7 of the Government Code. The information shown in these drawings reveals information about the refinery's operation that could harm Chevron's competitive market position. Because of the sensitive and competitive nature of the information, Chevron Products Company requests that the BAAQMD afford the information Confidential Business Information treatment indefinitely. These drawings are not subject to public disclosure as a public record without the express written consent of Chevron Products Company.

Appendix D – Technical Summaries of Compressors  
and Fuel Gas System  
Chevron Richmond Refinery Flares

This section included in Trade Secret Transmittal,  
Submitted under separate cover.

**Trade Secret Information**

Drawings in this Appendix are trade secrets of Chevron Products Company as defined in California Public Records Act, Section 6254.7 of the Government Code. The information shown in these drawings reveals information about the refinery's operation that could harm Chevron's competitive market position. Because of the sensitive and competitive nature of the information, Chevron Products Company requests that the BAAQMD afford the information Confidential Business Information treatment indefinitely. These drawings are not subject to public disclosure as a public record without the express written consent of Chevron Products Company.

## Appendix E – D&R Flare Relief and Mitigation Project: Project Specific Addendum

This section included in Trade Secret Transmittal,  
Submitted under separate cover.

### **Trade Secret Information**

Drawings in this Appendix are trade secrets of Chevron Products Company as defined in California Public Records Act, Section 6254.7 of the Government Code. The information shown in these drawings reveals information about the refinery's operation that could harm Chevron's competitive market position. Because of the sensitive and competitive nature of the information, Chevron Products Company requests that the BAAQMD afford the information Confidential Business Information treatment indefinitely. These drawings are not subject to public disclosure as a public record without the express written consent of Chevron Products Company.





# Flare Minimization Plan

Chevron Products Company - Richmond Refinery

D&R Flare & Relief Mitigation Project

Project Specific Addendum



**Chevron Products Company  
Richmond Refinery**

**Flare Minimization Plan  
Project-Specific Update**

**D & R Flare & Relief Mitigation Project**

**Submitted to**

**Bay Area Air Quality Management District**

**February 22, 2012**

## **TABLE OF CONTENTS**

<b>Section</b>	<b>Page</b>
<b>1.0 Project Summary</b>	<b>1</b>
<b>1.1 Trade Secret Information</b>	<b>2</b>
<b>2.0 Technical Data</b>	<b>2</b>
<b>2.1 Description of South Yard Flaring System</b>	<b>2</b>
<b>2.2 Detailed Diagrams for South Yard Flaring System</b>	<b>7</b>
<b>2.3 Monitoring and Control Equipment</b>	<b>7</b>
<b>3.0 Past Reductions</b>	<b>9</b>
<b>4.0 Planned (Future) Reductions</b>	<b>12</b>
<b>5.0 Prevention Measures</b>	<b>13</b>
<b>6.0 Other information requested by APCO</b>	<b>13</b>

### **Appendices**

**Appendix A – Simplified Flow Diagrams**

**Appendix B – Flare P&IDs**

**Appendix C – Flare Elevation Drawings**

**Certification Statement**

Based on information and belief formed after reasonable inquiry, I, Richmond Refinery HES Manager, certify that this Flare Minimization Plan Project Specific Addendum for the D&R Flare & Relief Mitigation Project is accurate true, and complete.

  
\_\_\_\_\_

Signature

*Feb. 23, 2012*

Date

## **1.0 Project Summary**

Chevron Products Company (Chevron) is submitting this Project Specific Flare Minimization Plan (FMP) Addendum for the D&R Flare & Relief Mitigation Project pursuant to the requirements of Regulation 12, Rule 12, which was adopted by the Bay Air Quality Management District (BAAQMD) on July 20, 2005. The BAAQMD has issued the Authority to Construct (ATC) and associated permit conditions (Permit to Operate – Application No. 22634, Condition No. 24921) for the project. This project specific FMP addendum provides supplemental project related information in support of the ATC and Permit to Operate. The D&R Flare (S-6015) is one of two flares associated with the Refinery's South Yard Area relief system. The LSFO Flare (S-6010) is the primary South Yard relief system flare. In 1997, Chevron submitted Application No. 17855 to install S-6015 as a replacement to Thermal Flare (S-6005). The BAAQMD subsequently issued the Authority to Construct and Permit to Operate. The D&R flare has operated intermittently since that time, having last operated in 2002. The D&R Flare has primarily been maintained as a backup unit during LSFO Flare maintenance activities. The D&R Flare is being returned to service in order to comply with updated API recommended practices, Chevron Standards, and Process Safety Management requirements. As specified in the permit conditions for the project, the D&R Flare will operate on a staged basis as the secondary South Yard flare. Water seal settings for the two flares will be maintained so that the D&R Flare will only begin operating as the LSFO Flare approaches its smokeless operating capacity. The permit conditions for the D&R Flare additionally allow for the D&R Flare to be utilized as the primary South Yard flare whenever the LSFO Flare is out of service for inspection and maintenance.

The Refinery's South Yard relief system currently discharges to the LSFO Flare when operational controls and flare gas recovery systems cannot accommodate a specific relief event. Relief studies for the Refinery's South Yard have historically estimated the worst case relief load at approximately 900,000 lbs/hr. Changes to the API calculation methods now utilize more conservative heat and material balances in calculating the potential worst case emergency relief loads. As a result, Chevron's current relief study indicates that the existing operating LSFO Flare and portions of the relief system header would be undersized for the worst case power failure relief scenario of 2,459,350 lb/hr. The current rated capacity of the South Yard relief system is 1.978MM lb/hr (LSFO Flare capacity of 878,910 lb/hr plus the D&R Flare capacity of 1,100,000 lb/hr). Implementation of the following project scope of work will increase the D&R Flare capacity to 1,635,600 lb/hr, bringing the calculated total South Yard relief system capacity to 2,459,350 lb/hr. The increase in capacity is a function of reduced system pressure drop and new flare tip efficiency.

- Install a new upgraded flare tip in S-6015 to increase capacity to 1,635,600 lb/hr;
- Change anti-surge water seal liquid level in S-6015;
- Install a fixed flare monitoring camera, automated sampling stations, and Panametric flow monitoring on S-6015 for Regulation 12-11 compliance;
- Increase section of 10" diameter relief line to 24" diameter between the NHT and No. 4 Rheniformer facilities;
- Increase steam supply piping diameter between S-6010 and S-6015.

The project will not change the existing quantity of plant emissions that could be routed to the relief system. Actual relief system flows are not changing, rather only the estimated relief load calculation method has changed. Relief flows will merely be routed to the existing LSFO flare and D&R Flare on a staged basis to better accommodate the potential maximum calculated emergency relief

**Chevron Richmond Refinery - Flare Minimization Plan - Project Specific Addendum  
D&R Flare & Relief Mitigation Project**

---

scenario. The LSFO Flare will retain its 30" water seal depth and the D&R Flare will have the flexibility to operate with a water seal depth between 30" and 62".

The use of a refinery flare for safety reasons is consistent with Regulation 12, Rule 12, Section 101. The timing, volume, and duration of a relief event are independent of the quantity and size of flares available to abate relief gas emissions. Consistency with the objective of continued flare minimization will be achieved by operating the LSFO Flare and D&R Flare in a staged manner under a combined vent gas mass flow rate permit limit. The D&R Flare is being returned to service in response to updated API calculation methodologies for estimation of worst case relief scenarios. The additional relief system capacity resulting from S-6015 being returned to service is consistent with flare minimization as a result of the permit conditions issued to the project. The LSFO Flare and D&R Flare were each previously permitted with vent gas mass flow rate limits of 878,000 lbs/hr. The new permit conditions place a combined limit of 878,000 lbs/hr on both flares with the LSFO Flare being required to operate as the primary flare. The D&R Flare will only begin operation after the LSFO Flare approaches its smokeless capacity — and when LSFO flare is out of service. The two flares will operate in a staged manner with a combined vent gas mass flow rate limit of 878,000 lbs/hr total. The permit conditions for the D&R Flare provide an exemption to the combined vent gas mass flow rate limit during specifically defined major power outages.

## **1.1 Trade Secret Information**

Appendices A, B, and C to this project specific FMP addendum contain refinery-confidential information and are trade secrets of Chevron Products Company (Chevron). The referenced information consists of proprietary system and equipment design information of value to Chevron as defined by the California Public Records Act, Government Code Section 6254.7 et seq., and 40 CFR Part 2, Subpart B, 18 USC 1905 and 5 USC 552(b)(4). Because of the sensitive and competitive nature of the information, Chevron Products Company requests that the BAAQMD afford the information Confidential Business Information treatment indefinitely. The content of Appendices A, B and C in the public version of this FMP have been blocked out. Full copies of Appendices A, B and C will be included in a Trade Secret transmittal of the FMP, provided under separate cover.

## **2.0 Technical Data**

Pursuant to the requirements of Regulation 12, Rule 12, Section 401.1, the following section provides descriptions and technical information for the South Yard relief system as well as the upstream equipment and processes that send gas to that system.

### **2.1 Description of South Yard Flaring System**

The Richmond Refinery operates one flare system in the South Yard Area of the refinery. A Simplified Flow Diagram for this system is listed in the following Table 2-1, and is included in Appendix A to this document.

**Chevron Richmond Refinery - Flare Minimization Plan - Project Specific Addendum  
D&R Flare & Relief Mitigation Project**

---

**Table 2-1 Flare System Drawings (refer to Appendix A)**

<i>Drawing No.</i>	<i>Drawing Version</i>	<i>Drawing Title</i>
SY-1	December 28, 2011	South Yard Relief System

**South Yard**

The South Yard has five compressors available for flare gas recovery (FGR) service, a dedicated K-3950 plus dual service, process/FGR, compressors, K-1171/K-1171A and K-242/K-252.

The K-3950 South Yard FGR compressor is manually controlled by the D&R East operating crew and services only the LSFO and D&R flares. K-3950 has a recovery capacity of 2.35 MMSCFD at 100% loading. The compressor suction pressure is maintained at 7.0 inches water pressure by setting the compressor valves at one of four fixed values: 0, 50, 75 or 100%. The loading can be adjusted locally or remotely from the operator control room. The maximum cylinder discharge temperature is alarmed at 325 deg F. to prevent compressor damage. Compressors K-1171 and K-1171A, at # 4 Crude Unit, are dual-purpose compressors of 1.7 MSCFD capacity each. The primary purpose of K-1171 and K-1171A is to provide pressure control for C-1160 and C-1190 Naphtha Stabilizers in the Crude Unit. Compressors K-1171 and K-1171A can be individually or simultaneously run because they are dual FGR/process service, in order to supplement or spare K-3950 (if K-3950 FGR compressor output is down or limited). The typical annual loading on these compressors is 1.64 MSCFD (or <50% of available capacity). They have a maximum discharge gas temperature of 250 deg F to prevent compressor damage.

K-242 and K-252 compressors were converted for dual process/FGR service in December 2007 to provide additional flare gas recovery capacity in the South Yard. These conversions provide additional and dedicated flare gas recovery compressor capacity as well as reduce the dependency on the dual role K-1171 and K-1171A compressors. K-242 and K-252 compressors are Worthington two-stage, reciprocating units with a capacity of between 1.9 and 2.3 MMSCFD per compressor, depending on the molecular weight of the gas. Either K-242 or K-252 compressor is available for back-up FGR service (with the other compressor in dual process/FGR service).

K-242/K-252 provide approximately 2 MMSCFD dedicated back-up capacity to the existing flare gas recovery capacity of 2.35 MMSCFD provided by K-3950. With an additional 1.7 MMSCFD available from the dual service K-1171 or K-1171A, a total of 6.1 MMSCFD flare gas recovery capacity is provided against the current base load of 0.8 MMSCFD.

A review of compressor availability from 2003 forward indicates that at least three of the five compressors (K-3950/K-1171/K-1171A, and K-242/K-252) were available for FGR service at all times. The upgrades to K-3950, the availability of K-1171 or K-1171A and the conversion of K-242 and K-252 (see Table 4.1, Planned Improvements) are designed to provide reliable, dedicated and flexible spare capacity.

South Yard Flare Gas Recovery (FGR) Compressor K-3950 had internal upgrades completed in January 2007 to improve its flexibility in handling nitrogen. These included valves with a wider port and larger valve area, and an upgrading to the sealing plates from steel to an engineered plastic. The ammonium salting issue with K-3950 had been resolved after the installation of two carbon drums on the bulk storage perchloroethylene drum off gas line in August, 2007. These upgrades, and the conversion of K-242 and K-252, are designed to provide reliable, dedicated spare capacity.

**Chevron Richmond Refinery - Flare Minimization Plan - Project Specific Addendum  
D&R Flare & Relief Mitigation Project**

---

Schedules for preventive maintenance (PM) work on the K-3950, K-1171/K-1171A and K-242/K-252 are based on monitoring data.

If the overall FGR load approaches the capacity of the operating compressor, indication is provided by increasing relief header pressure, which will alarm prior to flaring. If the load increases, or a primary compressor shuts down, the back-up compressor is manually started by field personnel.

Once it is confirmed that the back-up compressor is operating, the board operator can load the spare compressor up to 100%. If a primary compressor has shut down, flaring would occur until the spare compressor picks up the full FGR load.

For the South Yard FGR compressors, the spare of either K-1171 or K-1171A is kept in the same "hot standby" mode. In certain instances a valve has to be switched in the field. Compressors K-242 and K-252 are operated in the same way. The spare of either K-242 or K-252 is kept on "hot standby" mode and a valve needs to be switched in the field.

This mode of operation allows the spare compressor to be available and fully loaded within a few minutes if the primary compressor is impacted or unavailable. This mode supports reliable operation through having planned preventative maintenance based on monitoring data for the running compressors, and ensuring that the spare compressor is available when needed.

Running the spare FGR compressor on a continual basis would unnecessarily increase operating run time on two machines to recover the same amount of gas. This would increase the risk that a compressor will not be available (due to preventative maintenance servicing / breakdown) when it is needed.

Compressors operate within specific parameters (or operating envelopes). When process flows are at the limits of the compressors operating envelope, additional control measures have to be introduced to maintain reliable process conditions and mechanical integrity. These measures introduce an additional level of complexity to the operation that is not present when one compressor is operating to adequately handle the load.

Having the standby compressor on "hot standby" ensures that if an event takes place that negatively impacts the on-line compressor, then the standby compressor is not exposed to the same adverse conditions and is therefore likely to be available for a quick response if needed. Operating two compressors in parallel would also waste considerable energy, as these compressors are driven by large motors.

During normal flare gas recovery conditions, the loss of the primary flare gas recovery compressor will not necessarily lead to flaring. Flare header pressure operates at slightly above atmospheric pressure, while the water seals on the flares are set at 18" Water Gauge or higher. There is, therefore, a period of time (the duration cannot be defined as it will vary depending on the conditions at the time) before the system pressure in the flare gas recovery header exceeds the water seal pressure, which allows for a period of time in order to start the standby compressor.

The current effective and reliable operation requires having a spare compressor. There is no benefit to run the spare compressors as long as the FGR load does not exceed the capacity of the current FGR compressors.

The South Yard Flare System is connected to relief systems from process units located in the Distillation & Reforming (D&R) division, the Utilities & Environmental (U&E) division and the Blending & Shipping (B&S) division. There are two flares connected to the South Yard system. These flares, and the process units associated with them, are listed in Table 2-2.



**Chevron Richmond Refinery - Flare Minimization Plan - Project Specific Addendum  
D&R Flare & Relief Mitigation Project**

**Table 2-2 South Yard Flare System Plant Sources**

<i>BAAQMD Flare No.</i>	<i>Flare Name</i>	<i>Process Units</i>
S-6010	LSFO	S-4226, FCC Gas Hydrotreater (FCC GHT) S-4233, Jet Hydrotreater (JHT) S-4234, #5 Naphtha Hydrotreater (5NHT) S-4235, Diesel Hydrotreater (DHT) S-4236, #4 Crude Unit (4CU) S-4282, Penhex Isomerization Unit (Penhex) S-4283, #4 Rheniformer (4CAT) S-4237, #5 Rheniformer (5CAT) S-4435, #5 H2S Plant (5H2S) Cogeneration Plant Sources Utilities Plant Sources
S-6015	New D&R flare (Anticipated startup date March 2012)	S-4226, FCC Gas Hydrotreater (FCC GHT) S-4233, Jet Hydrotreater (JHT) S-4234, #5 Naphtha Hydrotreater (5NHT) S-4235, Diesel Hydrotreater (DHT) S-4236, #4 Crude Unit (4CU) S-4282, Penhex Isomerization Unit (Penhex) S-4283, #4 Rheniformer (4CAT) S-4237, #5 Rheniformer (5CAT) S-4435, #5 H2S Plant (5H2S) Cogeneration Plant Sources Utilities Plant Sources

### **2.1.1 South Yard Electrical Power & Steam Supply**

The No. 1 Power Plant and Cogeneration Plants No. 1 and No. 2 are the primary high pressure steam generators for the South Yard. The steam supply system is a cascading network where steam is utilized by various equipment such as pumps and turbines and released into sequentially lower steam system supply headers. The South Yard Area flares use the 150 lb. steam supply to assist with smokeless flaring. In the event of a major power failure, steam is routed to critical users to maintain safe operations and minimize flaring. Under worst case power failure conditions it is estimated that the steam supply may last for approximately 1 hour. Figure 2-1 is a simplified schematic displaying the South Yard electrical power and steam supply systems during normal operations.

Electrical power is normally supplied to the Refinery through the Cogeneration plants and 800 psi steam turbine generator (approximately 125 MW). Supplemental electrical power is provided from PG&E's El Sobrante substation to Chevron's Standard Oil Switching Station (SOSS) via two lines (redundant double ended supply – typically 10 MW). The PG&E supply can provide full backup power to the Refinery in the event that all Cogeneration Plant power is lost. Summer weather

**Chevron Richmond Refinery - Flare Minimization Plan - Project Specific Addendum  
D&R Flare & Relief Mitigation Project**

conditions can limit the PG&E supply. Any single line can supply full power in the event that the other supply line fails. Electrical power is similarly distributed from the SOSS to the South Yard via the No. 3 Substation. A hierarchical load shed system shuts down various equipment systems in the event of a loss of electrical power. Electrical demand decreases upon loss of steam as various process units are forced to shut down. These systems provide safe backup prevention measures for minimization of potential flaring by maintaining electrical supply.

**Figure 2-1 Richmond Refinery South Yard Electrical Power & Steam Supply  
South Yard Electrical Power & Steam Supply Schematic**

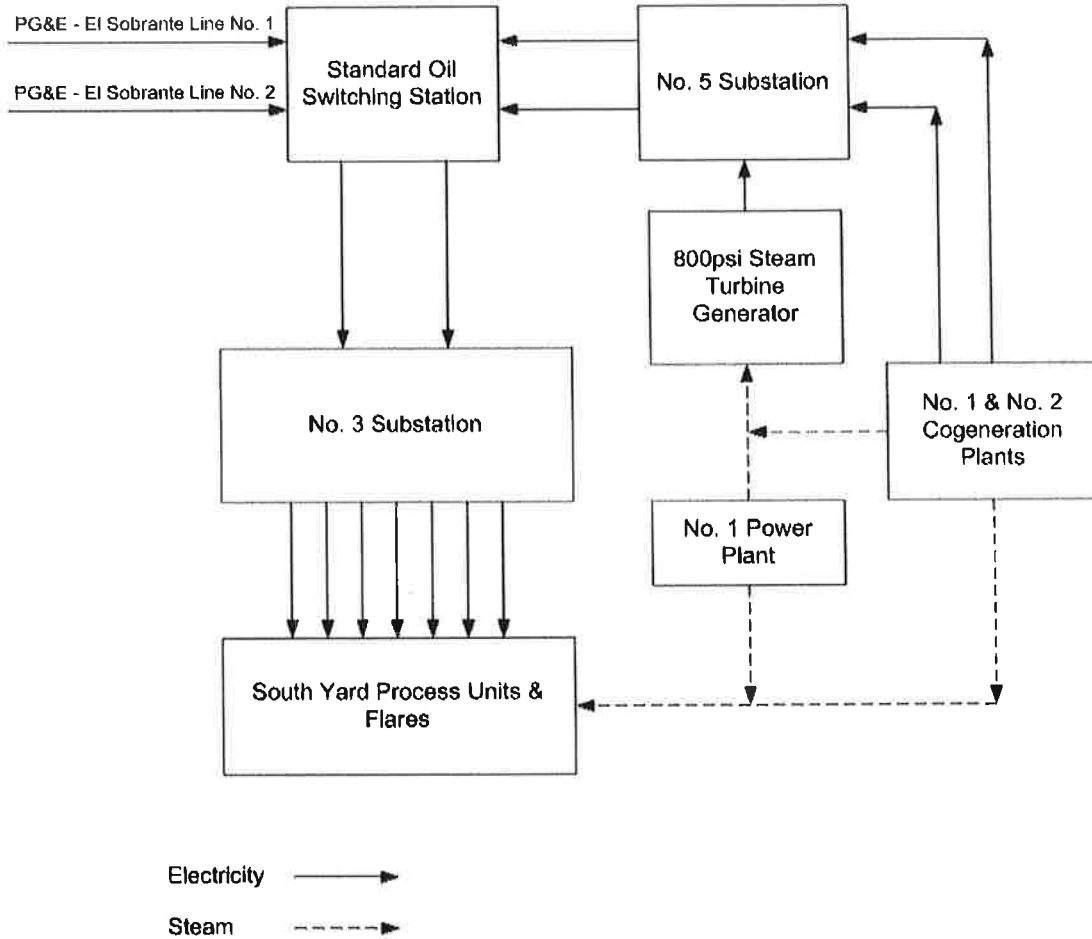

In calculating the relief load during the worst case power failure scenario, the Cogeneration Plants and all PG&E supplied power is assumed to be unavailable. Under that scenario, no backup electrical power is available from the Cogeneration plants or PG&E. The South Yard does maintain two back-up uninterrupted power supplies (UPS) for supply of electrical power to certain critical instrumentation systems. The South Yard Area flare vent gas sample systems, vent gas flow recorders, monitoring cameras and steam controls are tied into the UPS system.

**Chevron Richmond Refinery - Flare Minimization Plan - Project Specific Addendum  
D&R Flare & Relief Mitigation Project**

## 2.2 Detailed Diagrams for South Yard Flaring System

Table 2- provides a list of Piping & Instrumentation Diagrams (P&IDs) for each of the refinery's currently regulated South Yard flares. Copies of the P&IDs are located in Appendix B to this document.

**Table 2-3 Flare P&IDs** (refer to Appendix B)

<i>Drawing No.</i>	<i>Drawing Version</i>	<i>Flare or Flare System</i>
D-313651	Revision 19 (issued 9/20/2010)	LSFO Flare (S-6010)
D-329038	Revision 14A-1 (issued 8/18/2011)	New D&R Flare (S-6015)
D-368506	Revision 0 (issued 7/5/2011)	New D&R Flare (S-6015)
D-368375-1	Revision 1 (issued 8/25/2011)	New D&R Flare (S-6015)

Table 2-4 provides a list of mechanical elevation drawings for each currently regulated South Yard flares. Copies of the drawings are located in Appendix C to this document.

**Table 2-4 Flare Elevation Drawings** (refer to Appendix C)

<i>Chevron Drawing No. (Vendor No., if other)</i>	<i>Drawing Version</i>	<i>Flare or Flare System</i>
10640-2-F-40 (B-F-069761-302)	Revision 3	LSFO Flare (S-6010)
D-229930-0	Revision 0	LSFO Flare (S-6010)
D-228265-0	Revision 0	LSFO Flare (S-6010)
FP-207308 (B-F-913483-202)	Revision 6	D&R Flare (S-6015)

## 2.3 Monitoring and Control Equipment

### 2.3.1 Flare Gas Flow Monitoring

As required by BAAQMD Regulation 12 Rule 11, Section 501, all of the refinery's current active flares are equipped with continuous flare vent gas flow meters. The flow meters used for monitoring in the South Yard Area are listed in Table 2-5 and contain multiple outputs as shown.

**Table 2-5 Flare System Flowmeters**

<i>Tag Numbers</i>	<i>Name &amp; Location</i>	<i>Type</i>	<i>Ranges</i>
39FI002 39PI002 39TI002 39AI002	LSFO Flare vent gas flowmeter Installed on D&R Area relief line, between connection to South Yard FGR System and inlet to LSFO Flare (S-6010). P&ID D-313651	gas ultrasonic flowmeter	0 to 185 MMSCFD 13.8 to 20.1 PSIA 0 to 300 F 0 to 60 Gram/mol

**Chevron Richmond Refinery - Flare Minimization Plan - Project Specific Addendum  
D&R Flare & Relief Mitigation Project**

<i>Tag Numbers</i>	<i>Name &amp; Location</i>	<i>Type</i>	<i>Ranges</i>
39FI030	<u>New D&amp;R Flare vent gas flowmeter</u>	gas ultrasonic flowmeter	0 to 300 MMSCFD
39PI030	Installed on D&R Area relief line, between connection to South Yard FGR System and inlet to New D&R Flare (S-6015). P&ID D-368506		13.8 to 30.9 PSIA
39TI030			0 to 800 F
39AI030			2 to 120 Gram/mol

**2.3.2 Other Flare Gas Continuous Recording Instruments**

As required by BAAQMD Regulation 12, Rule 12, Section 501, all of the refinery's active flares are equipped with continuous flare vent gas pressure and water seal level monitoring. The instruments used for vent gas pressure and water seal height monitoring in the South Yard Area are listed in Table 2-6.

Water Seals – The water seals for the LSFO and D&R flares, in the South Yard, use fresh water. The water supply for the LSFO and D&R flares is adjusted automatically with a level control valve to maintain the designated seal level. Water seal height transmitters for currently active flares are calibrated to read "0 inches" at the water level equivalent to zero effective inches of water seal.

Vent Gas Pressure – The flare flowmeter installations include vent gas pressure and temperature monitoring to convert flow rate measurement to engineering unit flow rates in standard cubic feet. The vent gas pressure indicators are located in the flare vent gas lines upstream of each flare connection to provide a measurement of the gauge line pressure (relative to atmospheric pressure) on the vent gas line side of the water seal.

**Table 2-6 South Yard Flare Vent Gas Pressure and Water Seal Level Indicators**

<i>Tag Number</i>	<i>Instrument (P&amp;ID #)</i>	<i>Instrument Type</i>	<i>Range</i>
39PI002	LSFO Flare vent gas pressure P&ID D-313651	Honeywell Pressure Transmitter, absolute pressure	13.8 to 20.1 PSIA
39LC003	LSFO Flare water seal level indicator. P&ID D-313651	Displacer Type Transmitter	0 to 37 inches water column
39PI030	New D&R Flare vent gas pressure P&ID D-368506	Honeywell Pressure Transmitter, absolute pressure	13.8 to 30.9 PSIA
39LC030 39LT031	New D&R Flare water seal level transmitters. P&ID D-329038	Displacer Type Transmitter	-25 to 450 inches water column

**Chevron Richmond Refinery - Flare Minimization Plan - Project Specific Addendum  
D&R Flare & Relief Mitigation Project**

### 3.0 Past Reductions

This section provides a description of equipment, processes or procedures that the Richmond Refinery installed or implemented in the South Yard Area to reduce flaring prior to initiating the D&R Flare & Relief Mitigation Project. Past changes, and the year in which they were implemented, are summarized below in Table 3-1.

**Table 3-1 Historical Changes to Reduce Flaring**

<i>Year Installed or Implemented</i>	<i>Flare System Affected</i>	<i>Equipment Item Added, Process Changed or Procedure Implemented</i>
2000	South Yard	Started placing crude unit vent gas recovery compressors in service as FGR compressors (when K-3950 FGR compressor output is down or limited) depending on availability. Either K-1171, K-1171A, or both are put in service using a manual procedure in the field. K-1171 and K-1171A can provide 1.7MMSCFD capacity apiece in combined FGR / process service. The additional FGR capacity provided by K-1171 and K-1171A reduces flaring by increasing the ability of the South Yard FGR system to recover all relief gas when K-3950 output is down or limited. (There is no benefit to running the spare compressors as long as the FGR load does not exceed the capacity of the current FGR compressors.) K-1171 and K-1171A are two-stage, Ingersoll-Rand model 2HSE2 25X14.5X9 reciprocating units.
2002	Both	Shutdown Flare Planning Process implemented for planned maintenance work during plant shutdowns (i.e., turnarounds).
2002	South Yard	Implemented source control to reduce relief gas flows into the South Yard Flare Gas Recovery system. The source control effort was an intensive look that was undertaken to identify sources of loading to the South Yard Flare Gas Recovery system, such as valves, vents and pressure relief devices. Identifying and controlling these sources reduced the overall load on the FGR system. The likelihood of flaring was reduced because the FGR compressors would be more likely to recover all of the flare gas generated.
2002/2003	Both	The "Fuel Gas Load Shed" procedure worksheet was revised. This procedure provides a series of operational steps to respond to situations where the fuel gas demand begins to dip, or when fuel gas production exceeds demand, and excess relief gas generation could eventually cause flaring, by reducing the load on the FGR system. This worksheet provides a sequence of steps that reduce process gas generation and/or create more uses for fuel gases generated. The Refinery Shift Coordinator monitors natural gas makeup to the fuel gas drums. If this make-up drops, it indicates that the fuel balance is approaching the point at which more gas could be produced than could be consumed. The Fuel Gas Load Shed procedure is implemented to provide a "cushion" to avoid situations causing flaring because there is more fuel gas produced than can be consumed. Some steps are taken to reduce the load on the fuel

**Chevron Richmond Refinery - Flare Minimization Plan - Project Specific Addendum  
D&R Flare & Relief Mitigation Project**

<i>Year Installed or Implemented</i>	<i>Flare System Affected</i>	<i>Equipment Item Added, Process Changed or Procedure Implemented</i>
		<p>gas system by creating more fuel gas consumers, for example as switching electric drivers to steam turbines, and increasing cold feed into units (which would require fuel gas consumption to heat up the feed). Some steps are taken to reduce the load on the fuel gas system by reducing the amount of gas generated, for example employing secondary cooling to increase heat transfer and condense more material in overhead systems; backwashing heat exchangers to increase their heat transfer, provide better cooling and reduce vent gas generation; raising process column pressures, which reduces the gas make-up required; and raising the LPG content of the gasoline streams.</p> <p>Curtailing refinery operations also reduces the load on the fuel gas system by reducing the amount of gas generated, such as stopping the offloading of LPG cars, reducing unit operating severity to reduce the amount of gas generated, and reducing unit throughputs to reduce gas make-up. This worksheet has been continually updated over the past twenty years as improvements are identified. The Fuel Gas Load Shed procedure is employed to respond to plant conditions which could cause a fuel gas imbalance. The response to any particular event is dependent on the operating conditions at the time and the exact cause of the FGR system reaching full capacity. In different scenarios some actions are more effective than others. This is not the optimal or even desirable mode of operations in most circumstances, as overall facility efficiency is reduced and facility emissions may increase. (When shutting down plants for maintenance, fuel gas load is not the issue, as more sources of fuel gas generation than fuel gas consumers are lost, so the Fuel Gas Load Shed procedure is not needed for planned shutdowns. Flaring that occurs during the planned shutdown process is due to the inability to stay on FGR while depressuring and purging equipment, rather than any fuel gas balance issues.)</p>
2003-2004	Both	<p>The E-1190 fogger capital project provided supplemental cooling to the overhead of the C-1190 Naphtha Stabilizer column in the Crude unit when ambient temperatures are expected to exceed 75 F. Cleaning fin fan heat exchangers for the summer months also provides greater cooling efficiency. Both of these reduce the generation of vent gases which would otherwise add to the load on the FGR systems. Reducing the load on FGR systems reduces the likelihood of flaring because the FGR compressors would be more likely to recover all of the flare gas generated. New operating procedures 4CU4765j, 4CU4770j, and 4CU4775j were implemented for operation of the E-1190 fogger. Operating procedure 4CU-NP-4780 was implemented for fin fan cleaning. These procedures are implemented when ambient temperatures are expected to exceed 75 F, as described above.</p>

**Chevron Richmond Refinery - Flare Minimization Plan - Project Specific Addendum  
D&R Flare & Relief Mitigation Project**

<i>Year Installed or Implemented</i>	<i>Flare System Affected</i>	<i>Equipment Item Added, Process Changed or Procedure Implemented</i>
2008	South Yard	A steam condenser was designed and installed to reduce loading on the relief system during steam cleaning of the process equipment. Use of a temporary condenser will be considered in future DHT turnaround events in order to minimize the amount of steam that flows to the relief header.
2009	South Yard	During the 2009 4CU Pitstop Maintenance, the 4CU Process Unit and several associated process plants in the Distillation and Reforming Business Area will consider implementing the following practices to minimizing flaring during planned maintenance; de-pressure to relief at a slower rate per revised procedures and depressuring DHT to a downstream process unit to a lower pressure target before sending material to relief. Operations implemented the identified flare minimization measures during a 2009 turnaround, and will consider implementing these practices in future turnarounds.
2007	Both	Multiple training sessions were conducted with operation staff to communicate the requirement of the FMP.
2007	Both	Flare source and meter database updates. Databases and tools have been developed to track sources by business locations, operation activities (shutdowns), valve types, and by dates when leaks are identified and fixed. They can also assist operation staff to make any necessary operational moves to minimize potential flaring.
2007	South Yard	Cogen LPG knock-out drum blow down valve installation. A new ¾" bypass valve was installed at Cogen's LPG knock-out drum in addition to its original 2" valve to enhance the control of blowdown rate.
2007 -2008	Both	A temporary back-up generator was installed in December 2007. A permanent back-up generator was installed and commissioned into service in April 2008. The existing C-840 emergency scrubber prevents the burning of H2S in the flare by absorbing the H2S in an aqueous ammonia solution. A temporary back-up generator was installed in December 2007. A permanent back-up diesel generator was permitted, installed, and commissioned into service in 2008. This addition will not alter 5 H2S or C-840 operations. Instead, it will ensure continuous circulation of the scrubbing solution during an unexpected power outage and therefore maintain decreased H2S concentrations.
2008	Both	Identify all valved sources to FGR systems. All drain and vent valves routed to FGR systems are being labeled to advise caution while being operated.
2011	South Yard	The D&R operating area employed condensing systems to assist with flare minimization during its 2011 turnaround, and will consider implementing these practices in future turnarounds.

## 4.0 Planned (Future) Reductions

Pursuant to the requirements of Regulation 12, Rule 12, Section 401.3, and 401.4.1 and 401.4.2 (feasible prevention measures) this section provides descriptions of any equipment, processes or procedures that the Richmond Refinery plans to install or implement to eliminate or reduce flaring in the South Yard Area.

Table 4-1 below summarizes planned improvements to effect further reductions in flaring. The procedural changes described below require a year in order to optimize the improvements, update tools and communicate and train employees. The planned dates shown are driven by equipment installation and procedural changes that take advantage of the equipment.

Causal analyses of flaring events identified actions to maintain plant reliability that would reduce the likelihood of incidents which could cause potential flaring. These actions included the inspection and repair of equipment components that were either implemented as part of normal operations, or were scheduled for the next plant turnaround.

Table 4-1 includes measures considered to reduce flaring from planned major maintenance activities. Table 4-1 also includes measures considered to reduce flaring that may occur because of issues of flare gas quality and quantity.

**Table 4-1 Planned Improvements to Reduce Flaring**

<i>Planned Date of Installation/ Implementation</i>	<i>Equipment Item to be Added, Process to be Changed or Procedure to be Implemented</i>	<i>Flare System Affected</i>	<i>Notes</i>
2003 – Ongoing	Installed an Uninterrupted Power Supply (UPS) system.	South Yard	The South Yard does maintain two back-up uninterrupted power supplies (UPS) for supply of electrical power to the flare vent gas sample systems, vent gas flow recorders, monitoring cameras and steam controls are tied into the UPS system.
January 2008 – On Going	Infra red (I.R.) camera has been used as a predictive maintenance tool.	Both	After a major overhaul, FGR compressors are inspected using the I.R. camera to evaluate compressor performance and to predict if maintenance is needed.
July 2007 – On Going	Site-wide flare minimization team	Both	A multidisciplinary team focused on flare minimization meets periodically to address the refinery's flare minimization issues. The team is made up of operations, planning, and environmental personnel. These meetings continue and action



**Chevron Richmond Refinery - Flare Minimization Plan - Project Specific Addendum  
D&R Flare & Relief Mitigation Project**

<i>Planned Date of Installation/ Implementation</i>	<i>Equipment Item to be Added, Process to be Changed or Procedure to be Implemented</i>	<i>Flare System Affected</i>	<i>Notes</i>
			items are identified, considered, and implemented on an on-going basis throughout the year.
March, 2012	Operation of the flares in a staged basis.	South Yard	<p>The LSFO Flare (S-6010) and D&amp;R Flare (S-6015) will operate on a staged basis. Under normal conditions, the D&amp;R Flare will only operate once the LSFO Flare approaches its smokeless capacity. Flaring through the D&amp;R Flare will therefore be minimized as specified in Condition No. 24921, Part 2.</p> <p>The LSFO Flare will remain the primary flare during any process unit startup or shutdown activities. When the LSFO Flare is out of service for maintenance, the D&amp;R Flare will operate as the primary South Yard flare. When the D&amp;R Flare serves as the only South Yard flare, the water seal level will remain set at a level higher than that of the LSFO Flare in order to further minimize flaring and maximize flare gas recovery and maintain safe operation.</p>

**5.0 Prevention Measures**

Existing Refinery FMP prevention measure provisions for the South Yard will remain unchanged by the project. No new prevention measures were identified that address the flaring that may be reasonably expected to occur:

- During planned maintenance, including start-up and shutdown, and
- Due to issues of gas quantity and quality.

**6.0 Other Information Requested by APCO**

The following information has been requested by the BAAQMD Air Pollution Control Officer with respect to the D&R Flare & Relief Mitigation Project.

**Chevron Richmond Refinery - Flare Minimization Plan - Project Specific Addendum  
D&R Flare & Relief Mitigation Project**

---

**Description of Potential Flaring Events:**

The D&R Flare is being returned to service to provide capacity for the calculated worst case power failure relief load and to allow for shut down, inspection and maintenance of the LSFO Flare.

The D&R Flare (S-6015) is not a new flare at the Refinery. The flare is an existing permitted source that was installed in 1997 and last operated in 2002. It replaced the Thermal Flare (S-6005) which was removed from service and dismantled. Upon project completion, the two flares (D&R Flare and LSFO Flare) will operate on a staged basis.

BAAQMD Condition No. 24921 defines the flaring events under which the D&R Flare is expected to operate.

- The LSFO Flare will remain as the primary South Yard flare. Under normal conditions, the D&R Flare will only operate once the LSFO Flare approached its smokeless capacity. Part 2 of Condition No. 24921 provides, "The owner/operator of S-6015 shall only use S-6015 when S-6010 approaches its smokeless capacity of 170,000 pounds per hour."
- The only scenario under which the D&R Flare will operate as the primary South Yard flare is when the LSFO flare is out of service for maintenance. Part 4 of Condition provides, "The owner/operator of S-6015 shall use S-6015 as the main Flare in the South Yard only when S-6010 is down for maintenance."
- Although the LSFO Flare will be maintained and operated as the primary South Yard flare, a major relief event could potentially require system relief through the D&R Flare. Part 3 of Condition 24921 provides, "The total combined vent gas mass flow limit of S-6010 and S-6015 contained in Part1b shall not apply during major power outages. For the purpose of this condition, a major power outage is defined as any time when both: (a) all of Chevron's Cogens are non-operational and (b) power supply from the utility is also unavailable".

In modeling the worst case power failure scenario, the following potential relief events would be expected to exceed the smokeless capacity of the LSFO flare and initiate flaring through the D&R Flare.

- Fire case for Fire Zone 2 in 5 Rheniformer. The case involves three relief valves C4-25, C4-21 & C4-36.
- Fire case for Fire Zone 8 in the Diesel Hydro Treater. The case involves relief valve C8-21, C8-44 and C8-45.
- Control valve failure case on V-430. The level control valve on separator V-430 fails open. The separator loses liquid level and vapor blow through occurs. This over pressures the downstream column C-440.
- Reflux failure on the #4 Crude Atmospheric tower C-1100. This is when the Atmospheric Top Circulating Reflux (top tower pump around) fails.

For each of the listed cases, the molecular weight and temperature does not change between flares. The relief vapors are from a single plant and are mixed together before they enter the main header. Only in the worst case scenario, where the relief vapors enter the main headers from more than one location will the compositions differ between flares.

**Chevron Richmond Refinery - Flare Minimization Plan - Project Specific Addendum  
D&R Flare & Relief Mitigation Project**

---

**Alternatives to the D&R Flare & Relief Mitigation Project Considered**

In evaluating the project, Chevron considered the following alternatives to D&R flare and for reduction in potential relief loads:

- **Do nothing alternative:** This option was not viable because the LSFO Flare requires a ten year inspection and maintenance effort under API codes. The D&R Flare is required as a backup flare during periods when the LSFO is out of service. A backup flare is required because the entire South Yard cannot be shutdown independently of North Yard operations. In addition, the capacity of the LSFO flare is insufficient for relief of the calculated major power failure relief case.
- **Install a new, larger flare in place of the LSFO Flare and D&R Flare:** This option was deemed to not be cost effective. The existing LSFO Flare and D&R Flare are existing permitted sources and have sufficient combined capacity for relief of the calculated worst case relief scenario. A new, larger flare would still be incapable of periodic inspection since a backup flare would not be available.
- **Install Level 3 High Integrity Protective Systems (HIPS) on No. 4 & No. 5 Rheniformer Recycle Compressors:** Chevron considered replacing some relief valves with Level 3 HIPS for reduction of potential flare loading. These instrumentation systems reduce potential overpressure events through multiple redundant control loops. The main disadvantage of Level 3 HIPS is these systems are more complex and require many different components to work as designed. The effectiveness of the system is highly dependent on the field design, device testing, and maintenance programs. The ability of the HIPS to adequately address over-pressure is limited by the knowledge and skill applied in the identification and definition of overpressure scenarios. With the relief valves removed, the HIPS becomes the "last line of defense," whose failure potentially results in rupture of the vessel or pipeline. HIPS add a failure mode that could increase the likelihood of plant upset and flaring. Chevron determined that the complexity of the maintenance program required for such systems and fluctuations in refinery operations made reliance on the existing relief system the safer alternative.
- **Install Level 3 High Integrity Protective Systems (HIPS) on NHT Distillation Column Reboiler Feed Pump:** For the reasons state above, HIPS were determined to be an improper application for the referenced pump. Concerns regarding the possibility of coking the NHT furnace upon a system electrical failure required that the auto-start steam supply turbine driver for the pump remain in service.

The options presented above would not alleviate the need for returning the D&R Flare to service. In order to inspect and maintain the LSFO Flare or a new larger flare, an alternative flare must be available for use since the entire South Yard cannot be shut down without a shutdown of the entire refinery. The GHT Plant, Cogeneration Plants, and Utilities at a minimum remain in operation during a South Yard shutdown. The D&R Flare was primarily installed in 1997 for this purpose. The LSFO Flare has not been inspected since the D&R Flare was removed from service. The ten year API inspection of the LSFO Flare became due in the first quarter of 2011.

**D&R Flare Impact on the South Yard Flare Gas Recovery System**

As explained in Section 2.1 above, the South Yard flare gas recovery (FGR) compressors are manually operated for flare minimization during normal refinery operations and minor upset

**Chevron Richmond Refinery - Flare Minimization Plan - Project Specific Addendum  
D&R Flare & Relief Mitigation Project**

---

conditions. Operations personnel increase the number of recovery compressors on an as needed basis for flare minimization. Flares are safety and abatement devices that only operate when flare minimization procedures such as operational controls and flare gas recovery systems cannot accommodate a specific relief event. The D&R Flare will only begin operation after the LSFO Flare approaches its smokeless capacity. The renewed operation of the D&R Flare will therefore have no impact on the FGR system.

The total capacity for the South Yard FGR compressors is approximately 0.43MM scfh. The worst case power failure scenario is estimated at 18.8MM scfh. The South Yard has a total of five compressors that can be utilized for FGR. Certain existing FGR compressors are utilized in dual service and are therefore readily available for FGR duty without any warm up period. Additional installed FGR capacity would typically remain idle and could not be started up quickly enough to cover the worst case power failure load. Continuous "standby" operation of additional FGR compressors would waste energy and increase emissions needlessly. In addition, the compressors are assumed to be inoperable during a power failure. In the event that backup power was available, the refinery would have insufficient storage capacity to contain the recovered vent gasses during a major upset. As safety devices, flares are typically only utilized when flare minimization procedures are overwhelmed by upset conditions. The addition of extra FGR capacity will not alleviate the need for returning the D&R Flare to service.

**Description of the new D&R flare's video monitoring system required by Reg. 12-11**

The D&R Flare video monitoring system is indicated on P&ID D-329038-14 (See Appendix B). The reference P&ID shows the video monitoring system cameras as 39XT3930 and 39XT3930A. These units are operable from the facility control house. Video feed is additionally recorded by the Refinery information network system. The monitoring system includes a Pelco Model C10DN Series Day/Night, CCD Ultra High Resolution Color Cameras.

## Appendix A – South Yard Simplified Flow Diagram

This section included in Trade Secret Transmittal

Submitted under separate cover

### **Trade Secret Information**

Drawings in this Appendix are trade secrets of Chevron Products Company (Chevron) as defined in California Public Records Act, Section 6254.7 of the Government Code. The information shown in these drawings reveals information about the Chevron Richmond Refinery's operation that could harm Chevron's competitive market position. Because of the sensitive and competitive nature of the information, Chevron requests that the BAAQMD afford the information Confidential Business Information treatment indefinitely. These drawings are not subject to public disclosure as a public record without the express written consent of Chevron.

## Appendix B – South Yard Flare P&IDs

This section included in Trade Secret Transmittal

Submitted under separate cover

### **Trade Secret Information**

Drawings in this Appendix are trade secrets of Chevron Products Company (Chevron) as defined in California Public Records Act, Section 6254.7 of the Government Code. The information shown in these drawings reveals information about the Chevron Richmond Refinery's operation that could harm Chevron's competitive market position. Because of the sensitive and competitive nature of the information, Chevron requests that the BAAQMD afford the information Confidential Business Information treatment indefinitely. These drawings are not subject to public disclosure as a public record without the express written consent of Chevron.

## Appendix C – South Yard Flare Elevation Drawings

This section included in Trade Secret Transmittal

Submitted under separate cover

### **Trade Secret Information**

Drawings in this Appendix are trade secrets of Chevron Products Company (Chevron) as defined in California Public Records Act, Section 6254.7 of the Government Code. The information shown in these drawings reveals information about the Chevron Richmond Refinery's operation that could harm Chevron's competitive market position. Because of the sensitive and competitive nature of the information, Chevron requests that the BAAQMD afford the information Confidential Business Information treatment indefinitely. These drawings are not subject to public disclosure as a public record without the express written consent of Chevron.